



LEV

Levelling Mounts

Height-adjustable machine feet

Height-adjustable machine feet from the LEV product group are maintenance-free and ready-for-installation.

The precise, adjustable LEV machine feet are used whenever machines require an adjustable, stable positioning.

Their function ensures the secure positioning of machinery and equipment, protecting them against damaging shocks and vibrations. LEV machine feet can be supplied in different sizes, from M10 to M24 threads, and can secure and bear loads in these sizes from 45 to 5,900 kg.

The selection of suitable machine feet is simply made via the given mass of the machine or plant distributed among the desired support points. A weight distribution within the system must be considered in such a way that the feet are also measured with the associated load component. If additional dynamic loads are exerted by the machine or plant, the next largest type must be chosen in a borderline static load case.

The mounts meet OSHA requirements for anchoring machines.

Properties

- Easy to level
- Vibration-reducing
- Noise-reducing
- Improved product quality
- Maintenance-free
- Compensates for floor unevenness
- Special models available on request
- Special vibration-isolating feet according to design and custom-made product

Areas of application

- Injection moulding machines
- Conveyors
- Production and processing centres
- Assembly stations
- Small presses, etc.

LEV M10 to M24

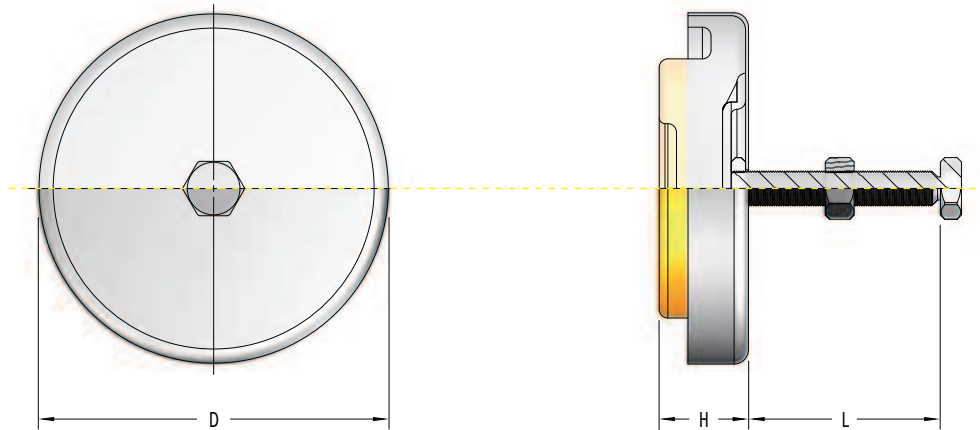

Type	Min. load kg	Max. load kg	Thread M	L mm	D mm	H mm
LEV-52221-M10	45	230	M10 x 1.5	80	80	38
LEV-52224-M12	135	450	M12 x 1.75	130	120	38
LEV-52226-M20	230	2040	M20 x 2.5	130	160	41
LEV-52229-M24	1815	5900	M24 x 3.0	180	230	57

Standard delivery with hexagon nut

Installation sketch

