





| 圆孔 | 带顶丝圆孔 | 材料 | 表面处理 | 热处理 | 精度 (GB/T 10095) |
|--------|--------|-------|----------|-----|-----------------|
| GBSNNC | GBSNNT | 碳素结构钢 | - | - | 8级 |
| GBSNBC | GBSNBT | | 四氧化三铁保护膜 | - | |
| GBCC | GBCT | 快削黄铜棒 | - | - | |
| GBSSC | GBSST | 不锈钢 | - | - | |

⊗ A型均无顶丝孔

按图定制

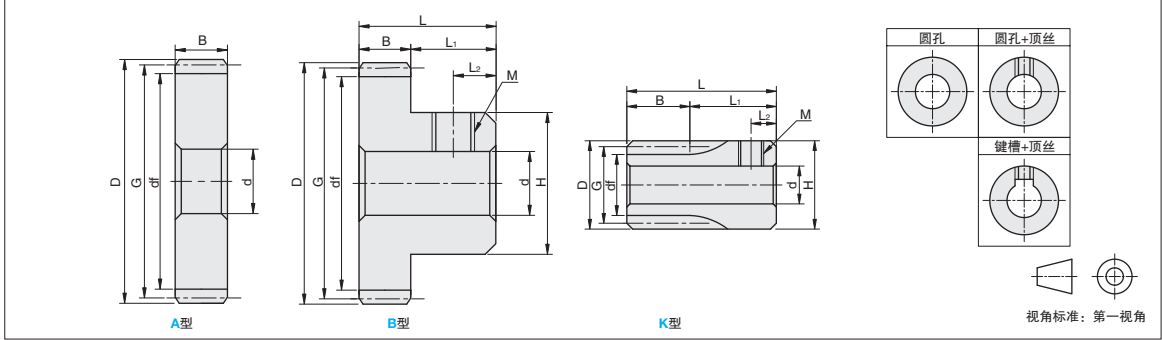



订购编号示例

1 代号 - 2 模数 - 3 齿数 - 4 厚度 - 5 齿轮形状 - 6 轴孔直径dr - 7 追加工

GBSNNC - 0.5 - 20 - 3 - A - d5

GBSNNC - 0.5 - 20 - 3 - A - d5 - SH3-20-K3

| 1 代号 | 2 模数 | 3 齿数 | 4 厚度B | 5 齿轮形状 | 6 轴孔直径d _{H7} | 分度圆直径 | | | | H | L | L ₁ | L ₂ | M (粗牙螺纹) | *许用扭矩(N·m) 弯曲强度 | | | |
|---|--|------|-------|--------|-----------------------|----------|-------|-------|-------|----|----|----------------|----------------|-------------|-----------------|-------|------|------|
| | | | | | | 圆孔 | G | D | df | | | | | | 碳素结构钢 | 快削黄铜棒 | 不锈钢 | |
| 圆孔 GBSNNC GBSNBC GBCC GBSSC | 0.5 | 15 | 8 | K | 3~5 | 7.5 | 8.5 | 6.25 | 9 | 18 | 10 | 3 | | | 0.72 | 0.16 | 0.41 | |
| | | 16 | | | | 8 | 6.75 | 0.79 | | | | | | | 0.17 | 0.45 | | |
| | | 18 | | | | 9 | 7.75 | 0.95 | | | | | | | 0.21 | 0.54 | | |
| | | 20 | | | 10 | 8.75 | 1.12 | 0.24 | 0.64 | | | | | | | | | |
| | | 20 | | | 10 | 8.75 | 0.42 | 0.09 | 0.24 | | | | | | | | | |
| | | 24 | | | 12 | 10.75 | 0.54 | 0.12 | 0.31 | | | | | | | | | |
| | 25 | 12.5 | 11.25 | 0.58 | 0.13 | 0.33 | | | | | | | | | | | | |
| | 28 | 14 | 12.75 | 0.68 | 0.15 | 0.39 | | | | | | | | | | | | |
| | 30 | 15 | 13.75 | 0.74 | 0.16 | 0.42 | | | | | | | | | | | | |
| | 32 | 16 | 14.75 | 0.8 | 0.17 | 0.46 | | | | | | | | | | | | |
| | 带顶丝圆孔 GBSNNT GBSNBT GBCT GBSST | 0.5 | 36 | 3 | A | 3~6-6.35 | 18 | 19 | 16.75 | 10 | 8 | | | | M3 | 0.94 | 0.2 | 0.54 |
| | | | 40 | | | | 20 | 18.75 | 0.72 | | | | | | | 0.16 | 0.41 | |
| 45 | | | 22.5 | | | | 21.25 | 0.83 | 0.18 | | | | | | | 0.48 | | |
| 48 | | | 24 | | | | 22.75 | 0.9 | 0.2 | | | | | | | 0.51 | | |
| 50 | | | 25 | | | | 23.75 | 0.95 | 0.21 | | | | | | | 0.54 | | |
| 60 | | | 30 | | | | 28.75 | 1.18 | 0.26 | | | | | | | | | |
| 2 | | 70 | 35 | 33.75 | 1.42 | 0.31 | | | | | | | | | | | | |
| | | 80 | 40 | 38.75 | 1.65 | 0.36 | - | | | | | | | | | | | |
| | | 100 | 50 | 48.75 | 2.13 | 0.46 | | | | | | | | | | | | |
| | | 120 | 60 | 58.75 | 2.59 | 0.56 | | | | | | | | | | | | |

▲表中许用扭矩为一般条件下计算得出的参考值。



▲追加工，键槽详情请参阅 P.1109

D6
齿轮
齿条

