

# MARKING AND CLEANING TOOLS



## WE GENERATE EXCITEMENT.

Since the foundation of the company in 1890 until today the goal has remained the same: the highest quality in products and services. Nevertheless, the circumstances, tasks and challenges have changed, of course. By focussing on our core areas of expertise, we have long set new standards for innovative clamping technology - driven by our own development, the greatest possible flexibility and passion for individual solutions.

All this is only possible with committed and contented employees. Respectful interaction with others, personal development and measures for the wellbeing of each individual are therefore values that matter to us.



Company Management:  
Wolfgang Balle, Johannes Maier (CEO), Jürgen Förster

## OUR COMPANY HISTORY

- 1890 Company founded as a lock manufacturer by Andreas Maier.
- 1920 Product range extended to include spanners.
- 1928 Production line assembly of FELLBACH LOCKS.
- 1951 Introduces clamping elements and diversifies into workpiece and tool clamping technology.
- 1965 Toggle clamps extend the AMF product range, AMF catalogues are now printed in ten languages.
- 1975 Further specialisation into hydraulic clamping technology.
- 1982 Clamping and fixture systems round off AMF's clamping expertise.
- 1996 AMF team organisation in all sectors of the business, Quality management with certification to ISO 9001.
- 2001 AMF Service Guarantee for all products.
- 2004 Introduction of the ZPS zero-point clamping system.
- 2007 The magnetic clamping technology extends the AMF product range.
- 2009 Development and marketing of AMF Vacuum clamping technology.
- 2012 LOW-COST AUTOMATION gripping, clamping, marking and cleaning.
- 2014 AMF presents the most extensive product range of automation solution in zero-point clamping technology.
- 2017 Wireless sensing systems extend the expertise into Industry 4.0 and blends seamlessly into the AMF product range.

## PLEDGES THAT COUNT IN EVERYDAY LIFE

For this reason, we have a few principles that we follow by conviction and which always apply..

### INDIVIDUAL DEVELOPMENT

Even if the product you need does not even exist yet, we will find the right solution with you: from special designs to new developments, everything is possible.

### WARRANTY

If, despite our high quality standard, there is a complaint, this is dealt with quickly and unbureaucratically, even beyond the warranty period.

### HIGHEST QUALITY STANDARDS

Careful manufacturing based on tradition since 1890, and naturally with a modern quality management system according to ISO 9001 for many years.

### SHORT DELIVERY TIME

With over 5,000 articles in our warehouse, you can expect your order to be dispatched on the same day.

### COMPETENT SERVICE FROM EXPERTS

Your local retail partner or the specialists in our team will find the right solution for every task.

### MADE IN GERMANY

Our entire product range is developed and manufactured exclusively by our employees in Germany.

<p><b>THE MOST IMPORTANT THING ABOUT “AMF MARKING TOOLS“</b></p>	<p>4 - 7</p>
<p><b>AMF-MARKER</b></p> 	<p>8 - 13</p>
<p><b>AMF-WRITER</b></p> 	<p>14 - 19</p>
<p><b>AMF-CLEANER, CLEAN-CASE</b></p> 	<p>20 - 22</p>
<p><b>AMF-CLEANER, BALL AND STICK DESIGN</b></p> 	<p>23 - 26</p>

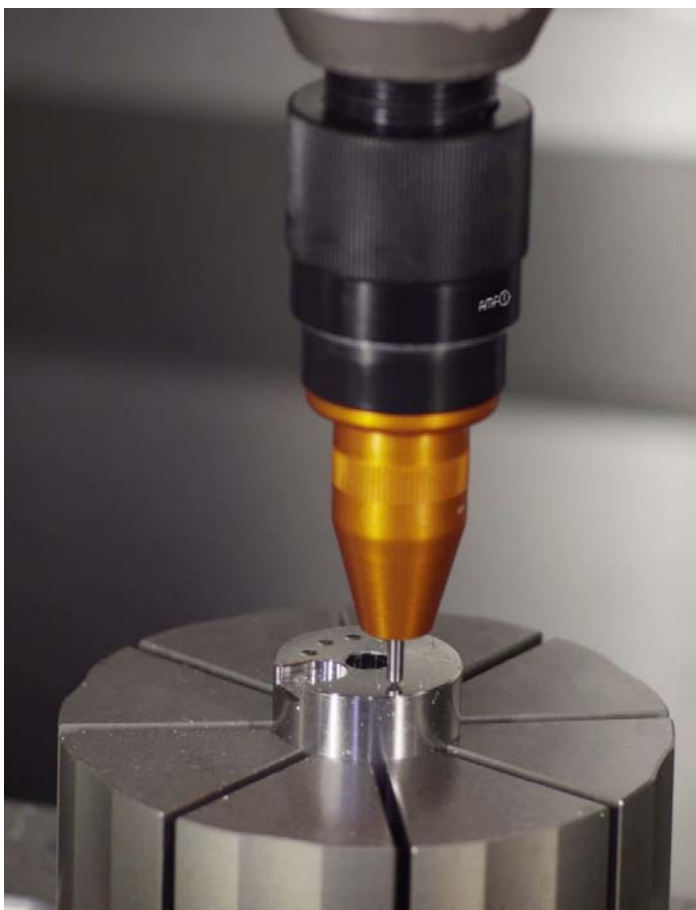

Subject to technical alterations.

# AMF MARKING TOOLS - AND YOUR MACHINE WILL MARK ECONOMICALLY

The AMF-Writers and AMF-Marker are tools for the permanent marking of workpieces. They are preferably clamped in collets and Weldon chucks and mounted in the machine spindle of a CNC machine.

Marking is accomplished through a combination of material compression and displacement, which we call "drumming". That means, the marking is made using a special needle with multiple refinements and an extremely hard tip.

Thanks to the special design and very high quality guides,

this tool can provide an even and high-quality marking without height adjustment by the spindle, for smooth and rough surfaces that can be uneven by between 3 and 9 mm. The adaptation to different materials, material hardness and implementation of different marking depths is infinitely adjustable.

This tool is particularly economical thanks to the low acquisition costs, long service life and tremendous time savings.

## YOUR BENEFITS AT A GLANCE:

- > the surface is not weakened or damaged, but is compressed and thus strengthened
- > high marking speeds are possible
- > high wear resistance and thus long service life
- > also suitable for thin-walled workpieces
- > no burrs appear on the marking line
- > high-quality type face
- > unevenness of the workpiece is compensated for (see Fig. 1)
- > also suitable for marking round surfaces (up to 15°)
- > depending on the design, it is possible to mark surfaces with a hardness of up to 57 HRC
- > no generation of noise

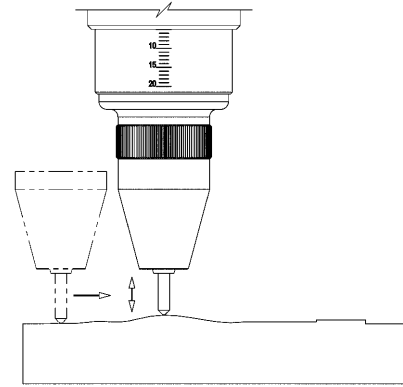

Fig. 1 Uneven workpiece surface

## PRODUCT OVERVIEW AMF-MARKER



## AMF MARKING TOOLS - AND THE PERFECT NEEDLE!

The heart of the AMF marking tools and the guarantee for a perfect written type face is the elaborately produced needle. This permits marking through a combination of material compression and displacement, which we call "drumming". That means, the marking is generated by the rounded point, which we also call a "ball". The optimal radius of these "balls" varies, depending on the material to be labelled, the breadth and depth of the lines and print size. Therefore, AMF carries several designs of the needle in order to ensure the best marking results.

The design of the needle is classified by the angle, radius and eccentricity of the point.

This means that a needle of design 90R10Ex01 has an angle of 90° at the tip of the needle and a radius of 1.0 mm as well as 0.1 mm eccentricity.

A needle of design 90R05Ex00 would accordingly have an angle 90°, a radius of 0.5 mm as well as 0.0 mm eccentricity, i.e. it is a centric needle.

We are happy to assist you in the search for the optimal needle for your application.

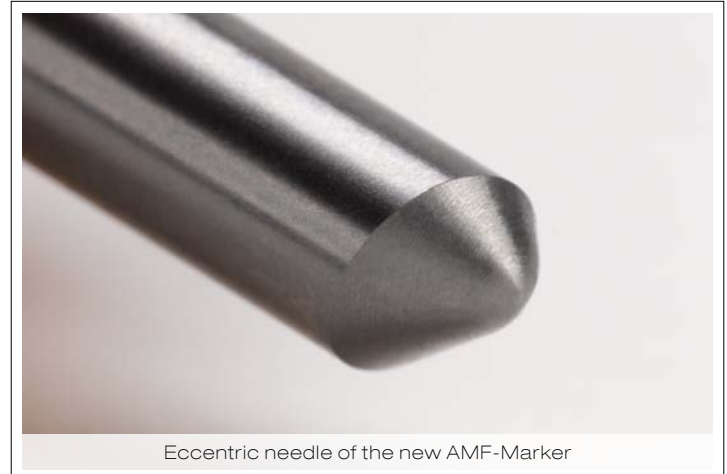

Eccentric needle of the new AMF-Marker



## CHOOSING THE MARKING TOOL -

HOW DO I FIND THE RIGHT TOOL FOR MY APPLICATION?

### TENDENTIOUS MATERIAL ALLOCATION OF AMF-MARKER:

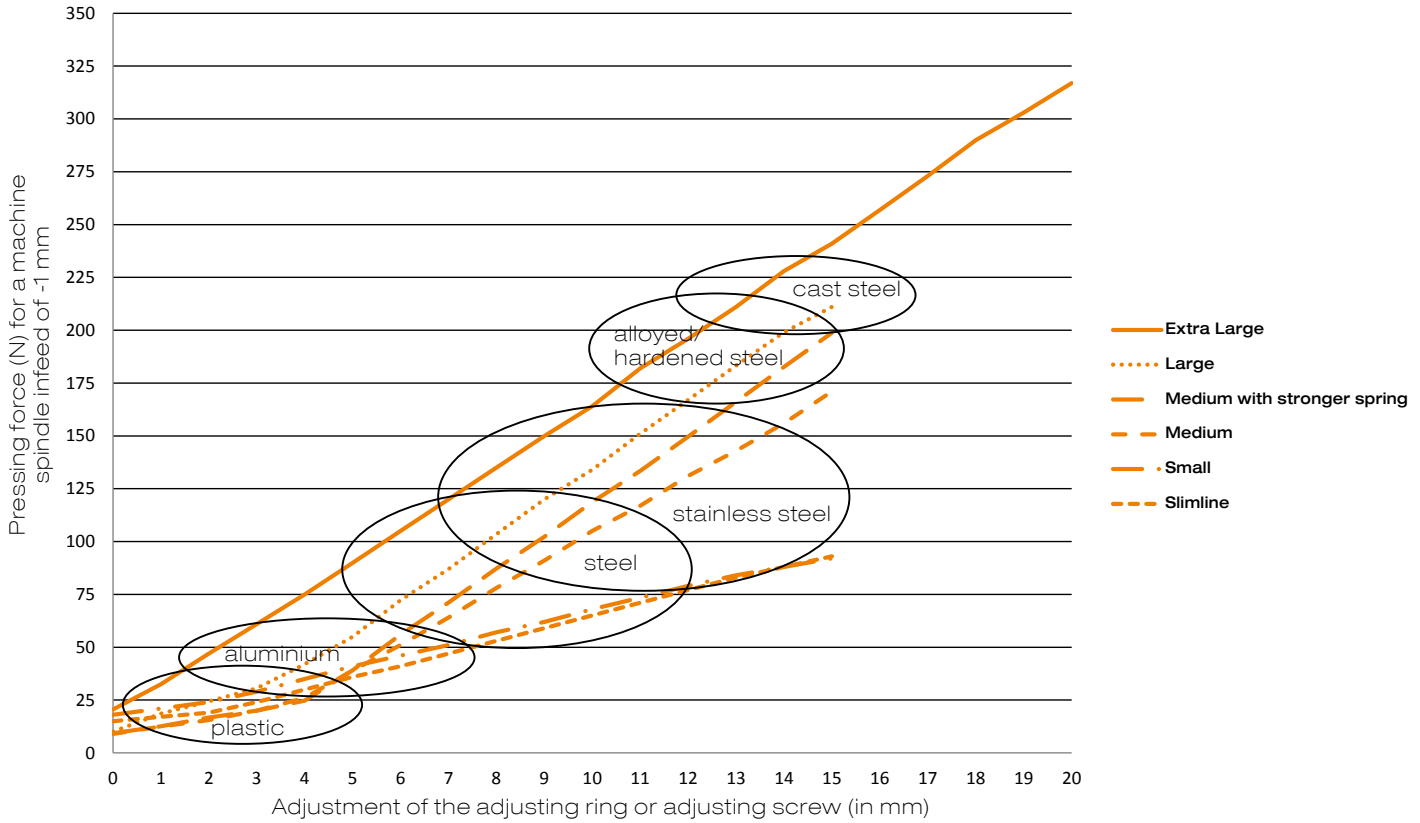

## CHOOSING THE MARKING NEEDLE -

HOW DO I FIND THE RIGHT NEEDLE FOR MY APPLICATION?

Small letters are compressed on wide lines and become illegible. The minimum legible type size is limited by the width of the letter lines.

Type size: Distance from upper and lower end of the letter.

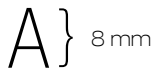

### MINIMUM LEGIBLE TYPE SIZE DEPENDING ON THE MARKING NEEDLE SELECTED:

90R03 Ex00	1.2 mm	90R10 Ex01	5.0 mm
90R05 Ex00	2.0 mm	90R10 Ex02	6.0 mm
90R10 Ex00	4.0 mm	90R10 Ex03	7.0 mm

In the case of a smaller radius, the same force affects a smaller surface, i.e. the font becomes deeper.

With eccentric needles you can produce a wider text.

# ARE YOU PRODUCING YET OR STILL LABELLING?

## THE CALCULATION IS QUITE SIMPLE!

Through use of the AMF marking tools, you demonstrably reduce your marking time in the machining centre by over 75%.

You avoid long times for marking, and your machine can already work on the next job - so you save money.

Take the time and simply calculate your savings potential with the AMF marking tool.

### SAMPLE CUSTOMER CALCULATION BEFORE AND AFTER USE OF THE AMF MARKING TOOL:

Procedure	Conventional marking process	Marking with the AMF marking tool
Machine costs (in €/hr)	100	100
Number of markings per shift (8 hr)	60	60
Time per marking procedure (in s)	60	12
Time per marking procedure per shift (in min)	60	12
Costs for marking per shift	100.00 €	20.00 €
Costs for marking per year (250 working days)	25,000.00 €	5,000.00 €
Annual savings per shift	<b>20,000.00 €</b>	

### DRASTICALLY REDUCED MARKING TIMES GUARANTEE YOU WILL EXPERIENCE A RAPID RATIONALISATION EFFECT

If previously 60 minutes had to be invested per shift for 60 markings in the machining centre, you reduce the pure marking time to 12 minutes through use of the AMF marking tool. Through the automated exchange of the workpiece and the ability of the tool to mark quickly, you achieve savings consistently.

The savings in our customer example of €60,000 per year, for three-shift production utilisation, guarantees rapid amortisation of the invested amounts of approx. €1,600 for an AMF-Writer Extra Large.

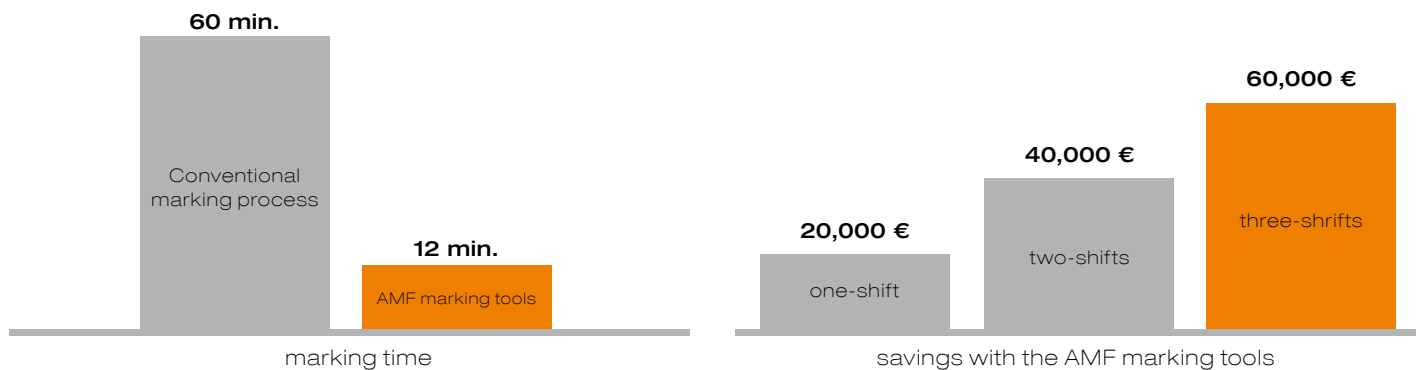

## No. 1550MXL

### AMF Marker Extra Large

Marking tool, suitable for 20 mm collets and Weldon holders (Weldon holders only when using the function check).  
Marking needles are not included.

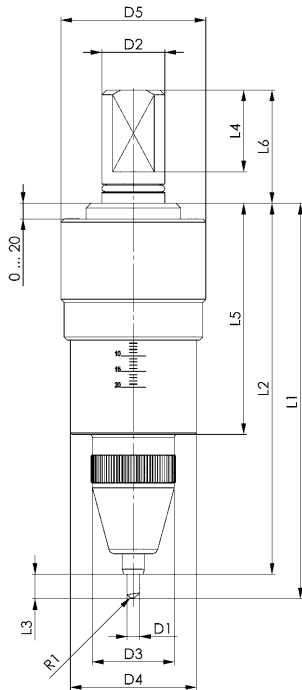

Order no.	D1 [mm]	D2 [mm]	D3 [mm]	D4 [mm]	D5 [mm]	L1 [mm]	L2 [mm]	L3 [mm]	L4 [mm]	L5 [mm]	L6 [mm]	Weight [g]
548180	4	20	26	40	46	125,5	118	7,5	26	74	36	326

#### Application:

##### Material and surface quality:

The AMF-Marker Extra Large is particularly suitable for the labelling of alloyed steel, hardened steel or cast steel. The surface of the component can be rough and uneven.

##### Type size and type width:

Centric marking needles are suitable for small letters and narrow lines. The font becomes wider by the use of eccentric marking needles and the rotation of the machine spindle. To ensure a good text, please observe the following note:

Spindle speed (1/min) / 10 = feed rate (mm/min)

Max. permissible spindle speed: 8,000 1/min

##### Needle pressure and batch size setting:

It is possible to adjust the needle pressure in the clamped state of the tool by the external adjusting ring. For this reason, we also recommend the AMF-Marker Extra Large for small batch sizes, or for batch size 1.

#### Features:

##### Change and choice of needle:

Instant change of needle by pulling out the marking needle using pliers, for example, with our special pliers No. 1530Z. Centric and eccentric needles are obtainable for the AMF-Marker Extra Large.

##### Function check:

Thanks to the possibility of checking the presence of the marking needle by means of an optional pneumatic dynamic pressure query, the AMF-Marker Extra Large is also ideally suited for use in automation.

#### Advantage:

- Labelling of alloyed steel, hardened steel or cast steel with rough and uneven surface
- Centric and eccentric marking needles available
- External adjusting ring for adjusting the needle pressure
- instant change of needle
- Function check possible

## No. 1550MXLN

### Marking needle

fits AMF Marker Extra Large No. 1550MXL.



Order no.	Needle	D1 [mm]	L1 [mm]	L2 [mm]	R1 [mm]	Weight [g]
550468	MXLN-90R05 Ex00	4	47	0,0	0,5	8
550469	MXLN-90R10 Ex00	4	47	0,0	1,0	8
550470	MXLN-90R10 Ex01	4	47	0,1	1,0	8
550471	MXLN-90R10 Ex02	4	47	0,2	1,0	8
550472	MXLN-90R10 Ex03	4	47	0,3	1,0	8

#### Note:

##### Centric marking needles:

550468: radius 0.5 mm, eccentricity 0.0 mm, minimum character size: legible from approx. 2 mm

550469: radius 1.0 mm, eccentricity 0.0 mm, minimum character size: legible from approx. 4 mm

##### Eccentric marking needles:

550470: radius 1.0 mm, eccentricity 0.1 mm, minimum character size: legible from approx. 5 mm

550471: radius 1.0 mm, eccentricity 0.2 mm, minimum character size: legible from approx. 6 mm

550472: radius 1.0 mm, eccentricity 0.3 mm, minimum character size: legible from approx. 7 mm

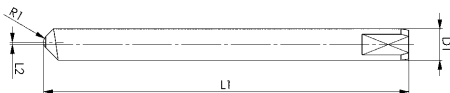



## No. 1560ML

### AMF Marker Large

Marking tool, suitable for 20 mm collets and Weldon holders (Weldon holders only when using the function check).  
Marking needles are not included.

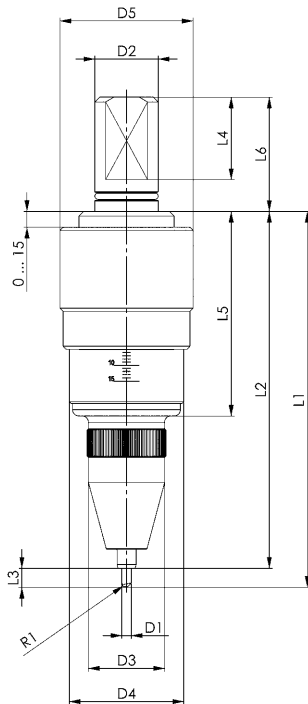

Order no.	D1 [mm]	D2 [mm]	D3 [mm]	D4 [mm]	D5 [mm]	L1 [mm]	L2 [mm]	L3 [mm]	L4 [mm]	L5 [mm]	L6 [mm]	Weight [g]
550223	3	20	24	36	42	119	113	6	26	65	36	263

### Application:

#### Material and surface quality:

The AMF-Marker Large is suitable for the labelling of different materials, but especially for the labelling of steel and stainless steel. The surface of the component can be uneven.

#### Type size and type width:

Centric marking needles are suitable for small letters and narrow lines. The font becomes wider by the use of eccentric marking needles and the rotation of the machine spindle. To ensure a good text, please observe the following note:

Spindle speed (1/min) / 10 = feed rate (mm/min)

Max. permissible speed: 8,000 1/min

#### Needle pressure and batch size setting:

It is possible to adjust the needle pressure in the clamped state of the tool by the external adjusting ring. For this reason, we also recommend the AMF-Marker Large for small batch sizes, or for batch size 1.

### Features:

#### Change and choice of needle:

Instant change of needle by pulling out the marking needle using pliers, for example, with our special pliers No. 1530Z. Centric and eccentric needles are obtainable for the AMF-Marker Large.

#### Function check:

Thanks to the possibility of checking the presence of the marking needle by means of an optional pneumatic dynamic pressure query, the AMF-Marker Extra Large is also ideally suited for use in automation.

### Advantage:

- Labelling of various materials, but especially labelling of steel and stainless steel, also with uneven surface
- Centric and eccentric marking needles available
- External adjusting ring for adjusting the needle pressure
- Instant change of needle
- Function check possible

## No. 1560MLN

### Marking needle

fits AMF Marker Large No. 1560ML.

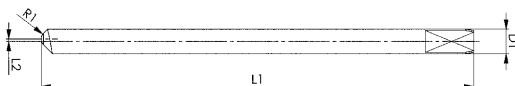

Order no.	Needle	D1 [mm]	L1 [mm]	L2 [mm]	R1 [mm]	Weight [g]
550473	MLN-90R05 Ex00	3	53,5	0,0	0,5	5
550474	MLN-90R10 Ex00	3	53,5	0,0	1,0	5
550475	MLN-90R10 Ex01	3	53,5	0,1	1,0	5
550476	MLN-90R10 Ex02	3	53,5	0,2	1,0	5
550477	MLN-90R10 Ex03	3	53,5	0,3	1,0	5

### Note:

#### Centric marking needles:

550473: radius 0.5 mm, eccentricity 0.0 mm, minimum character size: legible from approx. 2 mm

550474: radius 1.0 mm, eccentricity 0.0 mm, minimum character size: legible from approx. 4 mm

#### Eccentric marking needles:

550475: radius 1.0 mm, eccentricity 0.1 mm, minimum character size: legible from approx. 5 mm

550476: radius 1.0 mm, eccentricity 0.2 mm, minimum character size: legible from approx. 6 mm

550477: radius 1.0 mm, eccentricity 0.3 mm, minimum character size: legible from approx. 7 mm

## No. 1570MM

### AMF Marker Medium

Marking tool suitable for 20 mm collets and Weldon holders.  
552306: lower pressing force, ideally suited for aluminium in conjunction with marking needle 550479

556949: higher pressing force, ideally suited for steel and stainless steel

Marking needles are not supplied as standard.



Order no.	D1 [mm]	D2 [mm]	L1 [mm]	L2 [mm]	L3 [mm]	L4 [mm]	L5 [mm]	L6 [mm]	L7 [mm]	L8 [mm]	Weight [g]
552306	3	20	93	88	6	65	50	46,5	8	6	78
556949	3	20	93	88	6	65	50	46,5	8	6	78

**NEW!**

### Application:

#### Material and surface quality:

The AMF-Marker Medium is suitable for the labelling of different materials, but especially for the labelling of aluminium, plastic, steel and stainless steel. The surface of the component can be uneven.

#### Type size and type width:

Centric marking needles are suitable for small letters and narrow lines. The font becomes wider by the use of eccentric marking needles and the rotation of the machine spindle. To ensure a good text, please observe the following note:

Spindle speed (1/min) / 10 = feed rate (mm/min)

Max. permissible speed: 8,000 1/min

#### Needle pressure and batch size setting:

It is possible to adjust the needle pressure using the internal adjusting screw. Since the tool is removed from the holder to do this, we recommend the AMF-Marker Medium for medium and large batch sizes.

### Features:

#### Change and choice of needle:

Instant change of needle by pulling out the marking needle using pliers, for example, with our special pliers No. 1530Z. Centric and eccentric needles are obtainable for the AMF-Marker Medium.

#### Dimensions and machine size:

Thanks to its compact design, the AMF-Marker Medium fits into the tool magazine of milling machines and lathes.

### Advantage:

- Labelling of various materials, but especially labelling of aluminium, plastic, steel and stainless steel, also with uneven surface
- Centric and eccentric marking needles available
- Internal adjusting screw for adjusting the needle pressure
- Instant change of needle
- Compact design

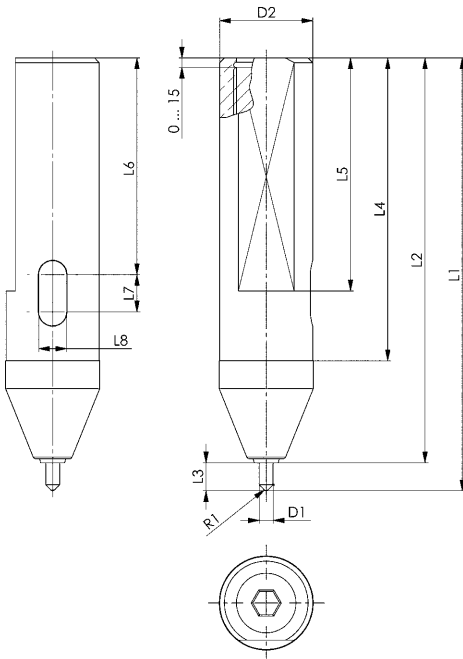

## No. 1570MMN

### Marking needle

fits AMF Marker Medium No. 1570MM.



Order no.	Needle	D1 [mm]	L1 [mm]	L2 [mm]	R1 [mm]	Weight [g]
550478	MMN-90R05 Ex00	3	36	0,0	0,5	3
550479	MMN-90R10 Ex00	3	36	0,0	1,0	3
552308	MMN-90R10 Ex01	3	36	0,1	1,0	3
552310	MMN-90R10 Ex02	3	36	0,2	1,0	3
552311	MMN-90R10 Ex03	3	36	0,3	1,0	3

### Note:

#### Centric marking needles:

550478: radius 0.5 mm, eccentricity 0.0 mm, minimum character size: legible from approx. 2 mm  
550479: radius 1.0 mm, eccentricity 0.0 mm, minimum character size: legible from approx. 4 mm

#### Eccentric marking needles:

552308: radius 1.0 mm, eccentricity 0.1 mm, minimum character size: legible from approx. 5 mm  
552310: radius 1.0 mm, eccentricity 0.2 mm, minimum character size: legible from approx. 6 mm  
552311: radius 1.0 mm, eccentricity 0.3 mm, minimum character size: legible from approx. 7 mm

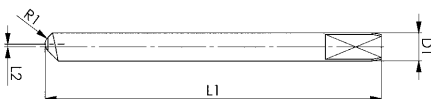

## No. 1580MS

### AMF Marker Small

Marking tool, suitable for 12 mm collets and Weldon holders.  
Marking needles are not included.

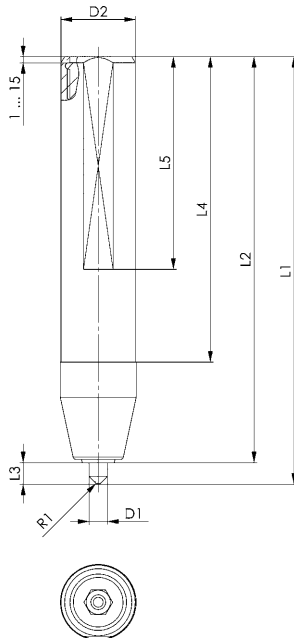

Order no.	D1 [mm]	D2 [mm]	L1 [mm]	L2 [mm]	L3 [mm]	L4 [mm]	L5 [mm]	Weight [g]
550225	3	12	69	66	3,5	49	34	21

### Application:

#### Material and surface quality:

The AMF-Marker Small is particularly suitable for the labelling of plastics and materials with similar material properties as well as for the labelling of steel and stainless steel. The surface of the component should already be machined.

#### Type size and type width:

Centric marking needles are suitable for small letters and narrow lines.

#### Needle pressure and batch size setting:

It is possible to adjust the needle pressure using the internal adjusting screw. Since the tool is removed from the holder to do this, we recommend the AMF-Marker Small for medium and large batch sizes.

### Features:

#### Change and choice of needle:

Instant change of needle by pulling out the marking needle using pliers, for example, with our special pliers No. 1530Z. Centric needles are obtainable for the AMF-Marker Small.

#### Dimensions and machine size:

Thanks to its very compact design, the AMF-Marker Small fits into the tool magazine of milling machines and lathes.

### Advantage:

- Labelling of plastics and materials with similar material properties, but also labelling of steel and stainless steel, with even surface
- Centric marking needles available
- Internal adjusting screw for adjusting the needle pressure
- Instant change of needle
- Very compact design

## No. 1580MSN

### Marking needle

fits AMF Marker Small No. 1580MS.

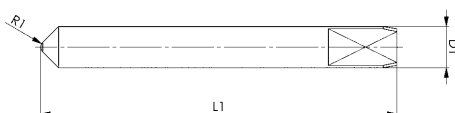

Order no.	Needle	D1 [mm]	L1 [mm]	R1 [mm]	Weight [g]
550481	MSN-90R03 Ex00	3	26	0,3	2
550480	MSN-90R05 Ex00	3	26	0,5	2

### Note:

#### Centric marking needles:

550481: radius 0.3 mm, eccentricity 0.0 mm, minimum character size: legible from approx. 1.2 mm

550480: radius 0.5 mm, eccentricity 0.0 mm, minimum character size: legible from approx. 2 mm

## No. 1590MSL

### AMF Marker Slimline

Marking tool with long, narrow tip, suitable for 12 mm collets and Weldon holders.

Marking needles are not included.

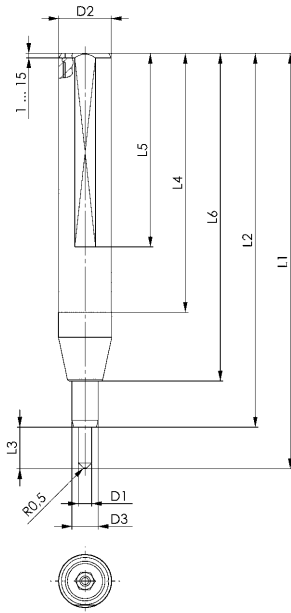

Order no.	D1 [mm]	D2 [mm]	D3 [mm]	L1 [mm]	L2 [mm]	L3 [mm]	L4 [mm]	L5 [mm]	L6 [mm]	Weight [g]
550226	3	12	6	95	86	9,5	59	44	75	29

### Application:

#### Material and surface quality:

The AMF-Marker Slimline is particularly suitable for the labelling of plastics and materials with similar material properties as well as for the labelling of steel and stainless steel in extremely confined spaces. The surface of the component can be slightly uneven.

#### Type size and type width:

Centric marking needles are suitable for small letters and narrow lines.

#### Needle pressure and batch size setting:

It is possible to adjust the needle pressure using the internal adjusting screw. Since the tool is removed from the holder to do this, we recommend the AMF-Marker Small for medium and large batch sizes.

### Features:

#### Change and choice of needle:

Instant change of needle by pulling out the marking needle using pliers, for example, with our special pliers No. 1530Z. Centric needles are obtainable for the AMF-Marker Slimline.

#### Dimensions and machine size:

Thanks to its very compact design, the AMF-Marker Slimline fits into the tool magazine of milling machines and lathes.

### Advantage:

- Labelling of plastics and materials with similar material properties, but also labelling of steel and stainless steel, with slightly uneven surface in extremely confined spaces
- Centric marking needles available
- Internal adjusting screw for adjusting the needle pressure
- Instant change of needle
- Very compact design

## No. 1590MSLN

### Marking needle

fits AMF Marker Slimline No. 1580MSL.



Order no.	Needle	D1 [mm]	L1 [mm]	R1 [mm]	Weight [g]
550483	MSLN-90R03 Ex00	3	42	0,3	4
550482	MSLN-90R05 Ex00	3	42	0,5	4

### Note:

#### Centric marking needles:

550483: radius 0.3 mm, eccentricity 0.0 mm, minimum character size: legible from approx. 1.2 mm

550482: radius 0.5 mm, eccentricity 0.0 mm, minimum character size: legible from approx. 2 mm

**No. 1530Z**

**Special pliers**

With one-sided plastic protective covering.

Order no.	B [mm]	L [mm]	Weight [g]
<b>552953</b>	55	150	150

**Application:**

The tool is suitable for fast and safe replacement of the marking needles of all AMF markers. It can be used for marking needles with diameters 3 and 4 mm.

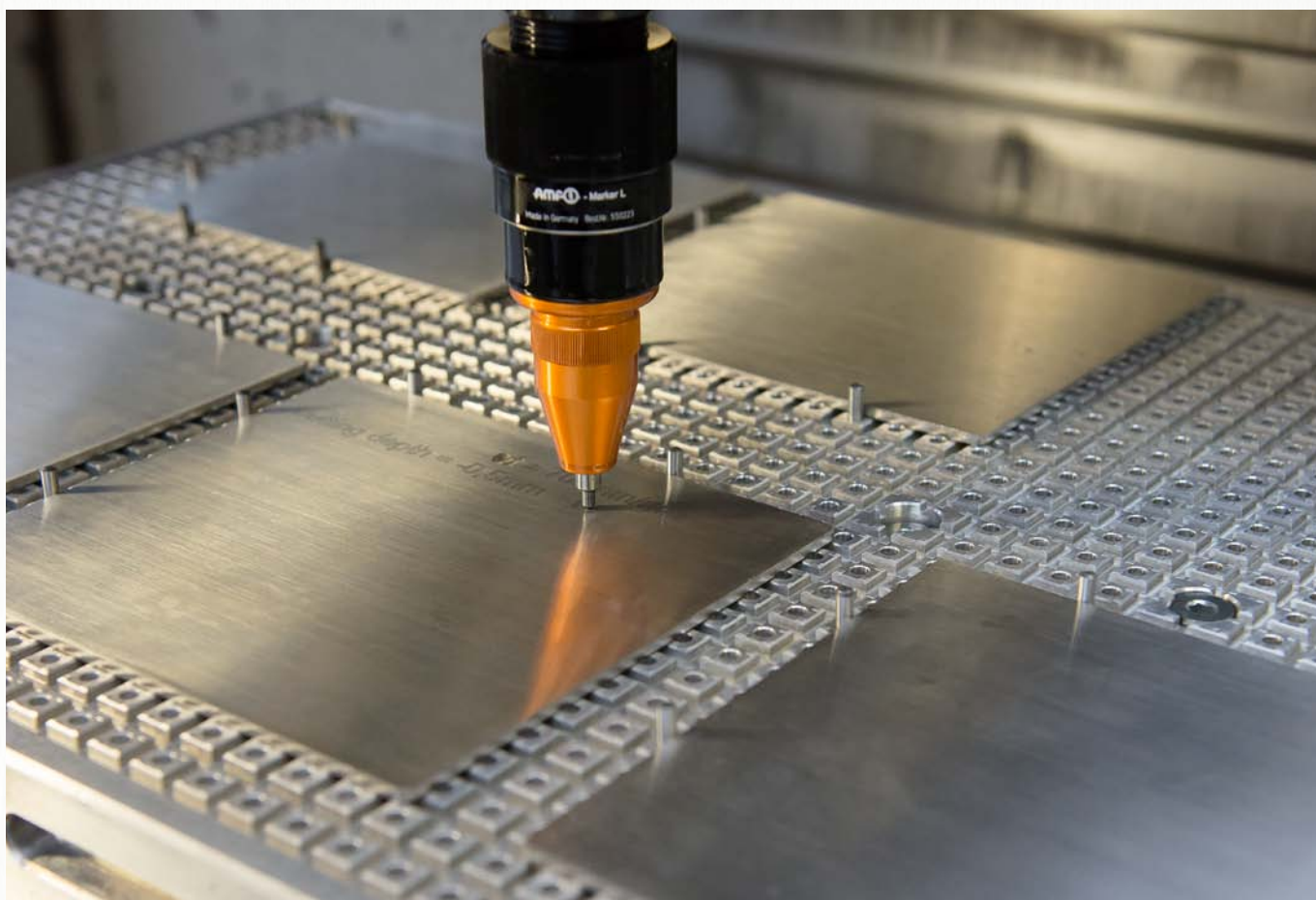

Subject to technical alterations.

## No. 1400WXL

### AMF-Writer Extra Large

Marking tool,  
fits 20 mm collets and Weldon holders.

Order no.	Needle	R1	Speed	Max. marking speed	Weight
		[mm]	[1/min]	[m/min]	[g]
17475	60R10 Ex00	1,0	0-300	200	318

#### Application:

This tool is especially suitable for marking uneven or rough surfaces with a large font (font size legible from 4 mm) and wide line thickness with a hardness of up to 50 HRC. Workpiece unevenness is compensated for. The marking speed depends on the feed rate of the machine and is independent of the spindle speed. The workpiece surface can be machined either dry or wet.

#### Features:

The AMF-Writer Extra Large has reinforced guides and a broader special needle. The setting is made continuously through a knurled nut and can be determined by means of a scale. Due to this setting capability with the knurled nut, the tool is optimally suited for small and medium lot sizes. The tool is held preferably in 20 mm collets or Weldon holders.

#### Advantage:

- Extremely high wear resistance
- Suitable for marking rough and uneven materials
- Easy adjustment by means of a knurled nut (possible also when clamped)

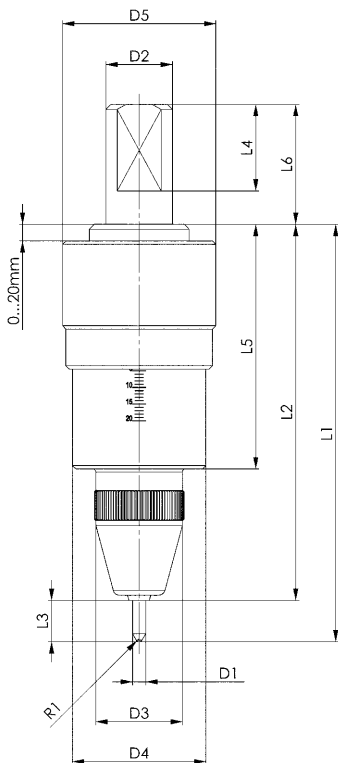

#### Dimensions:

Order no.	D1	D2	D3	D4	D5	L1	L2	L3	L4	L5	L6
	[mm]	[mm]	[mm]	[mm]	[mm]	[mm]	[mm]	[mm]	[mm]	[mm]	[mm]
17475	4	20	26	40	46	126	113	13	26	74	36

## No. 1410WL

### AMF-Writer Large

Marking tool,  
fits 20 mm collets and Weldon holders.

Order no.	Needle	R1 [mm]	Speed [1/min]	Max. marking speed [m/min]	Weight [g]
17418	90R10 Ex00	1,0	0-300	200	243
17426	90R05 Ex00	0,5	0-300	200	243

#### Application:

The tool is ideal for marking a wide variety of materials such as aluminium, titanium, steel, bronze, copper, brass, plastics etc.

Two needle types are available.

- Needle 90R10 Ex00 is optimal for marking with a large font (font size legible from 4 mm) and wide line thickness on surfaces with a hardness of up to 50 HRC.

- Needle 90R05 Ex00 is optimal for marking with a small font (font size legible from 2 mm) and medium, but deeper line thickness on surfaces with a hardness of up to 55 HRC.

Workpiece unevenness is compensated for. The marking speed depends on the feed rate of the machine and is independent of the spindle speed. The workpiece surface can be machined either dry or wet.

#### Features:

The AMF-Writer Large has high-quality guides and a robust special needle. The setting is made continuously through a knurled nut and can be determined by means of a scale. Due to this setting capability with the knurled nut, the tool is optimally suited for small and medium lot sizes. The tool is held preferably in 20 mm collets or Weldon holders.

#### Advantage:

- High wear resistance
- Suitable for marking a wide variety of materials
- Easy adjustment by means of a knurled nut (possible also when clamped)

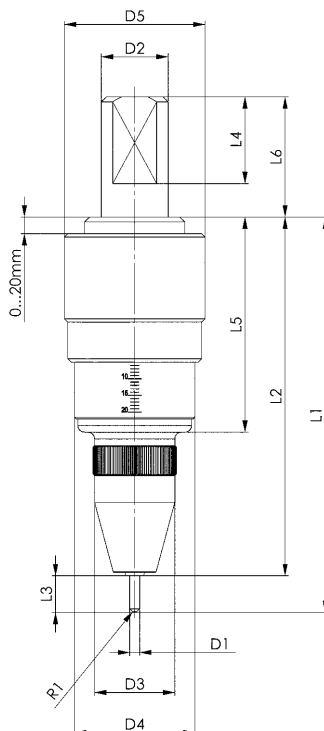

#### Dimensions:

Order no.	D1 [mm]	D2 [mm]	D3 [mm]	D4 [mm]	D5 [mm]	L1 [mm]	L2 [mm]	L3 [mm]	L4 [mm]	L5 [mm]	L6 [mm]
17418	3	20	24	36	42	119	108	11	26	65	36
17426	3	20	24	36	42	119	108	11	26	65	36

## No. 1420WM

### AMF-Writer Medium

Marking tool,  
fits 20 mm collets and Weldon holders.



Order no.	Needle	R1 [mm]	Speed [1/min]	Max. marking speed [m/min]	Weight [g]
17434	90R10 Ex00	1,0	0-300	200	78
17442	90R05 Ex00	0,5	0-300	200	78

#### Application:

The tool is ideal for marking a wide variety of materials such as aluminium, titanium, steel, bronze, copper, brass, plastics etc.

Two needle types are available.

- Needle 90R10 Ex00 is optimal for marking with a large font (font size legible from 4 mm) and wide line thickness on surfaces with a hardness of up to 50 HRC.

- Needle 90R05 Ex00 is optimal for marking with a small font (font size legible from 2 mm) and medium, but deeper line thickness on surfaces with a hardness of up to 55 HRC.

Workpiece unevenness is compensated for. The marking speed depends on the feed rate of the machine and is independent of the spindle speed. The workpiece surface can be machined either dry or wet.

#### Features:

The AMF-Writer Medium has high-quality guides and a robust special needle. Setting occurs steplessly via an inside screw, which can be adjusted using a hexagon wrench. Because this tool has to be removed from the holder in order to be set, it is optimally suited for large-scale production. The tool is held preferably in 20 mm collets or Weldon holders.

#### Advantage:

- High wear resistance
- Suitable for marking a wide variety of materials
- Compact design

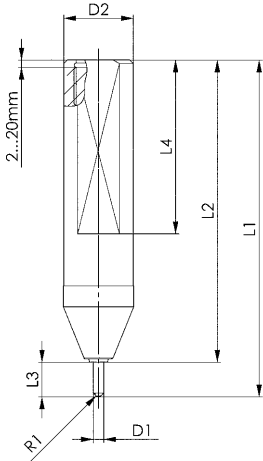

#### Dimensions:

Order no.	D1 [mm]	D2 [mm]	L1 [mm]	L2 [mm]	L3 [mm]	L4 [mm]
17434	3	20	97	87	10	50
17442	3	20	97	87	10	50

#### Examples of marking on various materials:

1. stainless steel 2. aluminium 3. plastics



Subject to technical alterations.



## No. 1430WS

### AMF-Writer Small

Marking tool,  
fits 12 mm collets and Weldon holders.

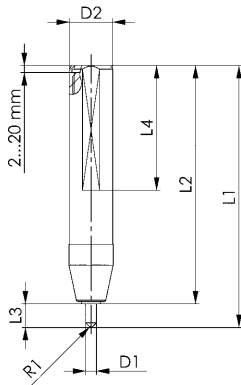

Order no.	Needle	R1 [mm]	Speed [1/min]	Max. marking speed [m/min]	Weight [g]
17459	90R05 Ex00	0,5	0-300	200	24
17467	90R03 Ex00	0,3	0-300	200	24

### Application:

The tool is ideal for marking a wide variety of materials such as aluminium, titanium, steel, bronze, copper, brass, plastics etc.

Two needle types are available.

- Needle 90R05 Ex00 is optimal for marking with a small font (font size legible from 2 mm) and medium line thickness on surfaces with a hardness of up to 55 HRC.
- Needle 90R03 Ex00 is optimal for marking with a small font (font size legible from 1.2 mm) and small, but deeper line thickness on surfaces with a hardness of up to 57 HRC.

Workpiece unevenness is compensated for. The marking speed depends on the feed rate of the machine and is independent of the spindle speed. The workpiece surface can be machined either dry or wet.

### Features:

The AMF-Writer Small has high-quality guides and a robust special needle. Setting occurs steplessly via an inside screw, which can be adjusted using a hexagon wrench. Because this tool has to be removed from the holder in order to be set, it is optimally suited for large-scale production. The tool is preferably received into 12 mm collets or Weldon holders.

### Advantage:

- High wear resistance
- Suitable for marking a wide variety of materials
- Very compact design

### Dimensions:

Order no.	D1 [mm]	D2 [mm]	L1 [mm]	L2 [mm]	L3 [mm]	L4 [mm]
17459	3	12	72	66	6	34
17467	3	12	72	66	6	34

## No. 1440WSL

### AMF-Writer Slimline

Marking tool with long, narrow tip, fits 12 mm collets and Weldon holders.



Order no.	Needle	R1 [mm]	Speed [1/min]	Max. marking speed [m/min]	Weight [g]
535146	90R05 Ex00	0,5	0-300	200	28
535161	90R03 Ex00	0,3	0-300	200	28

### Application:

The tool is especially well-suited for marking in a very confined spaces.

A wide variety of materials such as aluminium, titanium, steel, bronze, copper, brass, plastics etc. can be marked.

Two needle types are available.

- Needle 90R05 Ex00 is optimal for marking with a small font (font size legible from 2 mm) and medium line thickness on surfaces with a hardness of up to 55 HRC.

- Needle 90R03 Ex00 is optimal for marking with a small font (font size legible from 1.2 mm) and small, but deeper line thickness on surfaces with a hardness of up to 57 HRC.

Workpiece unevenness is compensated for. The marking speed depends on the feed rate of the machine and is independent of the spindle speed. The workpiece surface can be machined either dry or wet.

### Features:

The AMF Slimline writer has high-quality guides and a robust special needle. It has an outstanding narrow tip. Setting occurs steplessly via an inside screw, which can be adjusted using a hexagon wrench. Because this tool has to be removed from the holder in order to be set, it is optimally suited for large-scale production. The tool is preferably received into 12 mm collets or Weldon holders.

### Advantage:

- High wear resistance
- Suitable for marking a wide variety of materials
- Very compact design
- Long, narrow tip for use in confined spaces (e.g. in grooves)

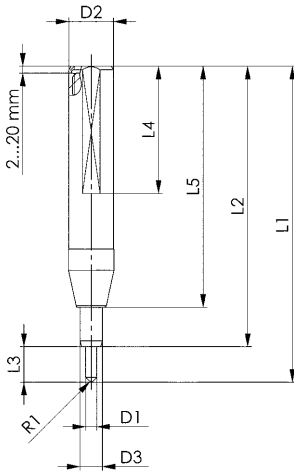

### Dimensions:

Order no.	D1 [mm]	D2 [mm]	D3 [mm]	L1 [mm]	L2 [mm]	L3 [mm]	L4 [mm]	L5 [mm]
535146	3	12	6	85	76	9	34	65
535161	3	12	6	85	76	9	34	65





# AMF-CLEANER AND YOUR MACHINE CLEANS ITSELF

AMF-Cleaners are tools for cleaning workpieces, tools and the interior of CNC machines. They are preferably clamped in Weldon chucks and mounted in the machine spindle of a CNC machine.

AMF Cleaners use through spindle coolant or compressed air.

AMF Cleaners in Stick design are available in lengths of 30, 100 and 180 mm and are ideally suitable for cleaning swarf from workpieces, vices and fixtures prior to unloading the workpiece and before the next workpiece is loaded. The spindle can be static or a slow rotation may be used to improve cleaning operation.

AMF Cleaners in the Ball design are available with horizontal or vertical connection to the machine spindle and are designed for cleaning the entire interior working area of the machine tool. The user selects which nozzles to open which controls the direction and pressure of the jet. Moving and rotating the spindle under constant flow of coolant achieves excellent and systematic cleaning of the machine interior.

Our AMF-Cleaners are characterised by low acquisition costs and a long service life - their time saving will impress you.

## Your benefits at a glance:

- > repeatable, systematic and thorough cleaning
- > no aerosol pollution harmful to the health of the machine operator
- > reduction of the cleaning time
- > preserves the machine guides
- > no risk of injury due to swarf



## No. 1500CC

### AMF-Cleaner

in Clean Case.  
Cleaning tools for attachment to the machine spindle, fits 16 mm  
Weldon holders.

Components:

- 1 AMF Cleaner, Ball Horizontal
  - 1 AMF Cleaner, Ball Vertical Control
  - 1 AMF Cleaner, Stick 30 mm
  - 1 AMF Cleaner, Stick 100 mm
  - 1 AMF Cleaner, Stick 180 mm
  - 3 multi-purpose nozzles
  - 1 pressure gauge
  - 1 adapter
  - 1 ball joint
  - 4 replacement lock screws
  - 1 hexagon screwdriver
- Operating Manual

#### BALL HORIZONTAL

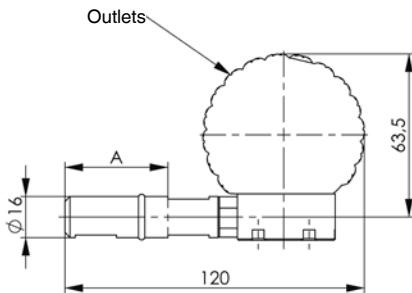

#### BALL VERTICAL CONTROL

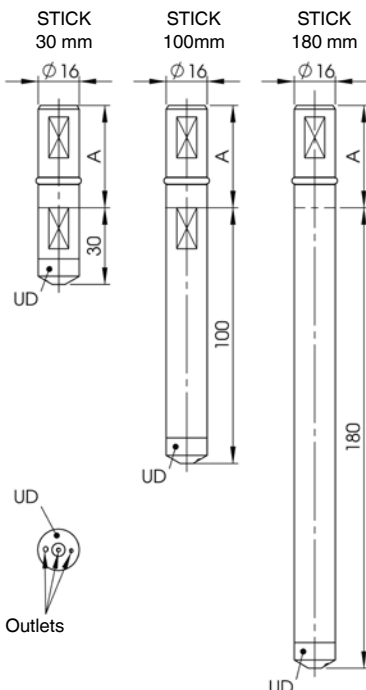
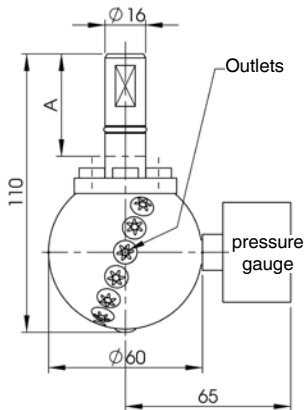

Order no.	Insertion depth A	Dimensions of case LxWxH	Weight
	[mm]	[mm]	[g]
17558	40	270 x 230 x 70	1637

### Application:

#### BALL:

The cleaning range of the AMF Cleaner is 360° and can be shaped through the number of opened outlets. The horizontal version of the tool with side connection even permits cleaning of the spindle tip. The control version allows connection of a pressure gauge to monitor the condition of the pump, filter and entire supply line.

#### STICK:

This tool is essential for automation of a CNC machine.

It gives the machine the ability to mechanically clean workpieces and clamping fixtures. The effect of the AMF Cleaner is adapted to the local conditions by the selective travel to different positions with a rotating tool. Due to its shape and the different lengths, it is especially well-suited for cleaning holes, pockets, undercuts or other contours. Thanks to 3 different universal nozzles (UN), the intensity of the cleaning jet can be influenced as well.

The adapters permit 2 cleaners to be connected together and extended in order to penetrate into lower-lying working areas.

The ball joint also enables an oblique nozzle position, allowing the jet angle to be controlled. The AMF Cleaner cleans at high-speed and can be integrated into the automation cycle quickly and easily by means of a short subroutine.

### Features:

#### BALL:

- Working range up to 360°
- KSS pressure range 5 to 120 bar
- Outlets (horizontal) 15
- Outlets (vertical) 14
- Minimum speed 5 rpm
- Maximum speed 100 rpm
- Working medium Cooling lubricant
- Weight, horizontal vers. 409 g
- Weight, vertical vers. 331 g

#### STICK:

- KSS pressure range 5 to 120 bar
- Compressed-air pressure range 5 to 10 bar
- Outlets 3
- Minimum speed 30 rpm
- Maximum speed 400 rpm
- Working medium Cooling lubricant, Compressed air
- Weight, vers. L=30 50 g
- Weight, vers. L=100 133 g
- Weight, vers. L=180 208 g

### Advantage:

#### BALL:

- Repeatable, systematic and thorough cleaning of the inside of the machine
- No aerosol pollution harmful to the health of the machine operator
- Reduction of cleaning time

#### STICK:

- Repeatable, systematic and thorough cleaning of the workpiece or clamping fixture
- No aerosol pollution harmful to the health of the machine operator
- Reduction of cleaning time



Subject to technical alterations.

## No. 1510CBVC

### AMF-Cleaner, Ball Vertical Control design

Cleaning tool for attachment to the machine spindle fits 16 mm Weldon holders.



Order no.	D1 [mm]	D2 [mm]	L1 [mm]	Insertion depth A [mm]	max. r.p.m. [1/min]	Min. KSS pressure [bar]	Max. KSS pressure [bar]	Weight [g]
17590	16	60	110	40	100	5	120	331

#### Application:

The cleaning range of the AMF Cleaner is 360° and can be shaped through the number of opened outlets. Through the optional installation of a pressure gauge, the status of the pump, filter and entire supply line can be checked.

#### Features:

Working range up to 360°  
Outlets 14  
Working medium Cooling lubricant

#### Advantage:

- Repeatable, systematic and thorough cleaning of the inside of the machine
- No aerosol pollution harmful to the health of the machine operator
- Reduction of cleaning time

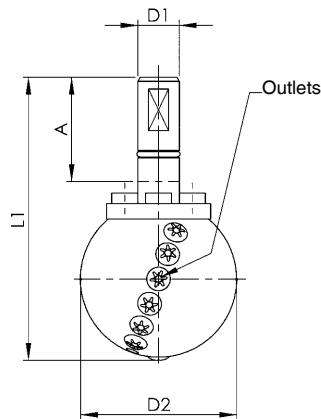

## No. 1510CBH

### AMF-Cleaner, Ball Horizontal design

Cleaning tool for attachment to the machine spindle fits 16 mm Weldon holders.



Order no.	D1 [mm]	L1 [mm]	L2 [mm]	Insertion depth A [mm]	max. r.p.m. [1/min]	Min. KSS pressure [bar]	Max. KSS pressure [bar]	Weight [g]
17582	16	120	64	40	100	5	120	409

#### Application:

The cleaning range of the AMF Cleaner is 360° and can be shaped through the number of opened outlets. This version of the tool with side connection even permits cleaning of the spindle tip.

#### Features:

Working range up to 360°  
Outlets 15  
Working medium Cooling lubricant

#### Advantage:

- Repeatable, systematic and thorough cleaning of the inside of the machine
- No aerosol pollution harmful to the health of the machine operator
- Reduction of cleaning time

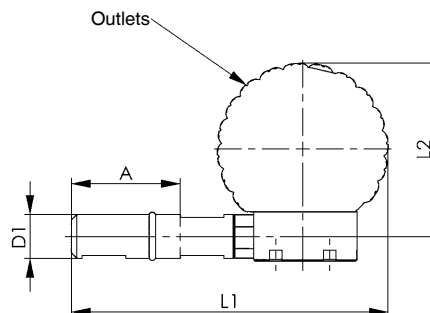

## No. 1510CZ

### Pressure gauge

Accessory for AMF Cleaner, ball design

Order no.	D1 [mm]	D2 [mm]	L1 [mm]	L2 [mm]	L3 [mm]	L4 [mm]	max. r.p.m. [1/min]	Min. KSS pressure [bar]	Max. KSS pressure [bar]	Weight [g]
17715	44	G1/8	26	34	46	14	100	0	60	67

#### Application:

The pressure gauge is screwed into the AMF Cleaner, Ball Vertical Control (CBVC) design, and serves to control the cooling lubricant pressure actually present. This is helpful for checking the necessary supply pressure of the AMF Cleaner, and the cooling lubricant pressure of the machine tool that is actually present can also be checked with this measuring tool. Based on this, conclusions can be made about the condition of the pump, filter and supply line.

#### Features:

Working medium    Cooling lubricant

#### Advantage:

- Possibility to check the KSS pressure of the machine tool
- Pressure necessary for AMF Cleaner can be checked

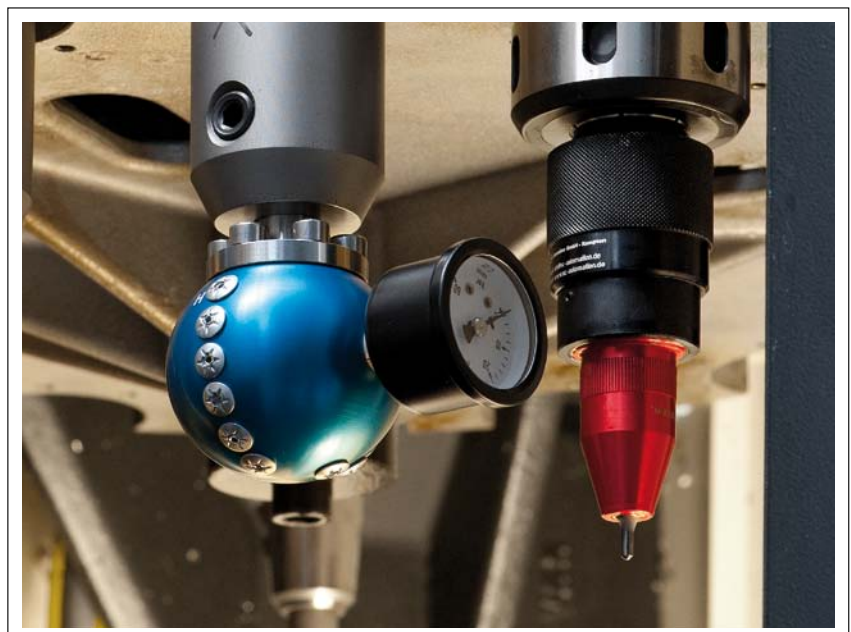
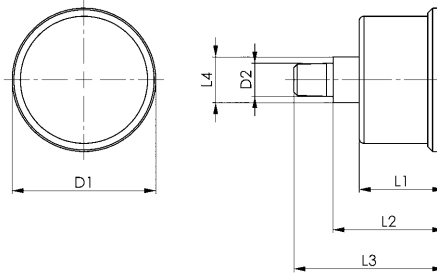

Subject to technical alterations.



## No. 1520CS

### AMF-Cleaner, stick design

Cleaning tool for attachment to the machine spindle fits 16 mm Weldon holders.

Designs:

Order No. 17608: Short

Order No. 17616: Standard

Order No. 17624: Long

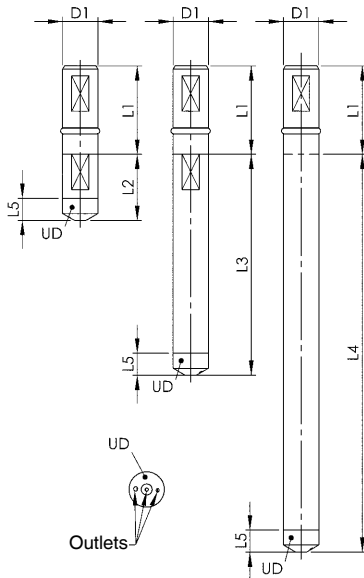

Order no.	Pipe	D1 [mm]	Insertion depth L1 [mm]	L2 [mm]	L3 [mm]	L4 [mm]	Weight [g]
17608	30	16	40	30	-	-	50
17616	100	16	40	-	100	-	133
17624	180	16	40	-	-	180	208

### Application:

This tool is essential for automation of a CNC machine. It gives the machine the ability to mechanically clean workpieces and clamping fixtures. The effect of the AMF Cleaner is adapted to the local conditions by the selective travel to different positions with a rotating tool. Due to its shape and the different lengths, it is especially suitable for cleaning holes, pockets, undercuts or other contours. Through selection from 3 different universal nozzles (UN), you can influence the intensity of the cleaning jet. The AMF Cleaner cleans at high-speed and can be integrated into the automation cycle quickly and easily by means of a short subroutine.

### Features:

KSS pressure range 5 to 120 bar

Compressed-air pressure range 5 to 10 bar

Outlets 3

Minimum speed 30 rpm

Maximum speed 400 rpm

Working medium Cooling lubricant, compressed air

Put your cleaner together individually. The pipe and universal nozzle are ordered separately.

### Advantage:

- Repeatable, systematic and thorough cleaning of the workpiece or clamping fixture
- No aerosol pollution harmful to the health of the machine operator
- Reduction of cleaning time

## No. 1520CZ

### AMF-Cleaner, universal nozzles

AMF Cleaner, fits stick design.

Designs:

Order No. 17632: Low flow

Order No. 17640: Standard

Order No. 17657: High flow



Order no.	Universal nozzle	D1 [mm]	L5 [mm]	Weight [g]
17632	UD40	16	10	14
17640	UD45	16	10	14
17657	UD50	16	10	14

## No. 1520CZ

### Ball joint and adapter

Accessory for AMF Cleaner, stick design  
 Order No. 17699: ball joint  
 Order No. 17673: adapter



Order No. 17699: ball joint

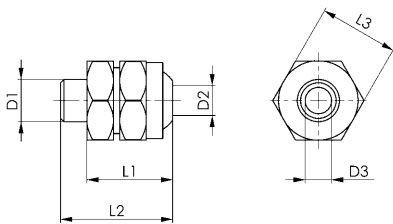

Order No. 17673: adapter

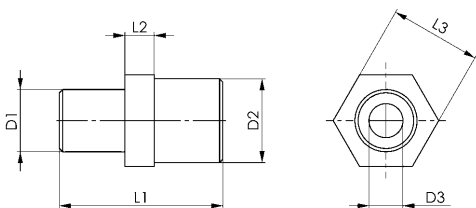

Order no.	max. r.p.m. [1/min]	Min. KSS pressure [bar]	Max. KSS pressure [bar]	Min. air pressure [bar]	Min. air pressure [bar]	Weight [g]
17699	60	5	120	5	10	66
17673	400	5	120	5	10	13

### Application:

#### Adapter:

Adapters are used to connect 2 or more AMF Cleaners to each other. The adapter is simply screwed on instead of the universal nozzle of an AMF Cleaner. The length of the cleaning tool can thus be varied.

#### Ball joint:

Ball joints are used to connect movably 2 or more AMF Cleaners to each other. The universal nozzle attached to the front or an additional AMF Cleaner can be deflected up to 30 degrees through the ball joint.

Order information: To deflect an additional AMF Cleaner, the adapter is needed in addition to the ball joint.

### Features:

Working medium    Cooling lubricant, compressed air

### Advantage:

- Modular design for individual applications
- Cost savings through simple expansion possibilities

### Dimensions:

Order no.	D1 [mm]	D2 [mm]	D3 [mm]	L1 [mm]	L2 [mm]	L3 [mm]
17699	G1/8	G1/4	8	26	34	24
17673	G1/8	G1/4	5,2	25	4,5	14



- + Outstanding price-performance ratio
- + Drastically reduced tooling time
- + Immediate improvement of productivity
- + Repeat accuracy <math>< 5\mu\text{m}</math>
- + Stainless steel
- + Form fit







# WE GENERATE EXCITEMENT - ON YOUR MOBILE DEVICE TOO

The "Clamping technology APP" offers you an overview of AMF's exciting clamping product range. No matter whether mechanical, pneumatic, hydraulic or magnetic clamping technology, as well as vacuum and zero point clamping systems - all the products are presented in detail in this APP, and you can see the numerous application options of AMF clamping technology at a glance.

All products can be downloaded as 2D and 3D CAD models, and be conveniently imported into all standard CAD programs.

Also stay up-to-date and read our news and PDF catalogues on your mobile device.

Test it now by downloading our clamping technology APP free-of-charge from the Apple App Store or Google Play.



**THE CLAMPING TECHNOLOGY APP -  
FIND PRODUCTS, DOWNLOAD  
CAD DATA, STAY INFORMED ...**



These Terms of Payment apply for companies, legal entities governed by public law and public law special funds. Our goods and services are supplied exclusively on the basis of the following conditions. Any deviating purchasing conditions of the customer not expressly recognised by us will not become part of the contract through acceptance of the order. By placing the order and accepting the goods we deliver, the customer confirms its consent to our terms and conditions.

## 1. Offer and contractual conclusion

All our offers are always subject to change without notice unless otherwise explicitly agreed. Our delivery contracts are based on the latest version of our catalogue. Dimension and weight values, as well as illustrations, drawings and data, are non-binding and can be changed by us at any time. Therefore, deviations cannot be ruled out and do not justify any compensation claims against us.

Orders are considered accepted only when confirmed by us in writing. If, for organisational reasons, the customer does not receive a separate confirmation upon the delivery of goods, the invoice shall also be deemed the order confirmation.

## 2. Prices

The prices are in EURO, ex-works, excluding VAT, packing, freight, postage and insurance. Unless otherwise agreed, our list prices valid on the day of delivery shall apply. For orders below 50 EUR goods net, we must make a minimum quantity surcharge of a 10 EURO for cost reasons.

## 3. Tool costs

Unless any other agreements have been reached, the tools fabricated for the purpose of executing the order shall remain our property in all cases, even if we have invoiced a tool cost component separately.

## 4. Payment

Unless otherwise stated on the invoice, the purchase price falls due for net payment within 30 days of the invoice date (without deduction of discount). Invoice amounts of below 50 EURO are due for payment immediately.

In case of payment default, we shall be entitled to charge default interest. The amount corresponds to our interest rate for current account credits at our main bank; the minimum however being 8 percentage points above the relevant base interest rate applied by the European Central Bank. Moreover, in case of default following written notice to the customer, we shall be entitled to cease to fulfil our obligations until payments are received.

## 5. No set-off

The customer can set-off only with legally confirmed or undisputed counterclaims.

## 6. Right of withdrawal in case of delayed acceptance or payment and insolvency

If the customer fails to accept the goods in due time, we shall be entitled to set a reasonable period of grace, after which we can dispose of the goods elsewhere and supply the customer on a reasonably longer term. Our rights to withdraw from the contract under the provisions of Section 326 BGB and demand damages for non-performance shall not be affected. If the customer fails to pay for the goods once payment is due, we shall be entitled, at the end of a reasonable period of grace we have set, to withdraw from the contract and demand the return of any goods already supplied. Section 323 BGB remains unaffected in all other cases.

If the customer applies for the opening of insolvency proceedings, we shall be entitled, prior to the ordering of security measures by the insolvency court, to withdraw from the contract and demand the immediate return of the goods.

## 7. Customer-specific fabrications/project fabrications (custom fabrications)

Customer-specific fabrications require binding information on design, quantity etc. in written form at the time of ordering. For manufacturing reasons, we reserve the right to supply up to 10% above or below the order quantity. Technical modifications or cancellations are subject to any costs incurred. The return of customer-specific fabrications is impossible.

## 8. Delivery and packaging, transfer of risk

The delivery date is non-binding; although stated to the best of our knowledge. It is subject to us receiving correct, defect-free and complete deliveries. The stated delivery dates relate to completion in the factory, starting on the day the order is accepted by us. Delivery is EXW (ex-works) in accordance with Incoterms 2010. Therefore, the costs are borne by the customer. The risk is transferred to the customer when the goods are passed to the person, company or facility nominated to execute the shipment. This applies also for partial deliveries, or if we have assumed responsibility for delivery and installation. The risk shall be transferred to the customer even in the case of delayed acceptance.

In the absence of specific shipping instructions, we shall proceed as we deem fit and without any obligation to the cheapest or most expedient method. The customer agrees that the order can also be delivered in parts, insofar as this is reasonable for the customer. We shall charge a 5 EURO processing free for shipping to third parties that we supply on behalf of the customer.

The packaging complies with the packaging ordinance. Disposable packaging shall be charged at cost price. The packaging cannot be taken back.

## 9. Performance impediment and/or impossibility

If we are hindered in the fulfilment of our obligation due to the onset of unforeseeable circumstances, which we are unable to avoid despite reasonable effort in relation to the nature of the circumstances (e.g. operational interruption, delay in the delivery of important raw materials, defects in the delivery), the delivery time shall be extended by a reasonable period, insofar as the supply of goods or services is not rendered unreasonably difficult or impossible.

If we have to accept that these circumstances are not only temporary, we shall be entitled to withdraw from the contract either in whole or in part.

If the supply of goods or services becomes impossible, the customer shall not be obliged to furnish its own contractual service. Section 275 BGB applies mutatis mutandis. If, however, the customer is solely or predominantly responsible for the

circumstances that led to impossibility, it shall remain under an obligation to render the return service. The same applies if this circumstance occurs at a time when the customer is behind schedule with acceptance.

## 10. Samples/returns

Samples shall be provided only against payment. If samples or models are provided, a credit note shall be issued with the subsequent order if the order value is 125 EURO net or more. Goods can be returned only by agreement, although custom fabrications are excluded from such return.

In the case of returns for which we are not responsible (e.g. incorrect order), we shall charge a processing fee of 10%, the minimum value, however, being 7.50 EURO.

## 11. Retention of title

The goods shall remain our property unless full payment of all claims and/or until the cheques provided for this purpose are honoured. The itemisation of claims in an ongoing invoice, as well as balancing the account and the recognition thereof does not affect the retention of title. The customer is entitled to sell on the retained goods during the ordinary course of business. However, the customer is not permitted to pledge the goods or transfer them by way of security. It shall assign its claim ensuing from the selling on of the retained goods to us in advance. The customer shall be entitled to collect the claim to the extent that it has fulfilled its obligations towards us. At our request, the customer shall be obliged to state third-party debtors and we shall be entitled to report this and the assignment.

## 12. Property rights

We reserve property rights and copyrights to all contractual documents such as drafts, drawings, calculations and cost estimates. Such documents must not be reproduced or disclosed to third parties without our consent. Any rights to patents, utility models etc. reside solely with us, insofar as such patents have not yet been filed. Our products are allowed to be replicated only with our written consent.

If objects are fabricated according to drawings or samples, the customer shall warrant that any third party property rights are not infringed by manufacture or delivery. If a third party forbids manufacture and delivery on account of property rights, we shall be entitled to stop manufacture and delivery immediately. The customer shall be obliged to reimburse us with all costs incurred and indemnify us from third party compensation claims. Compensation claims by the customer are impossible.

## 13. Warranty

If the customer agrees with us a particular quality of the goods, we shall base this agreement on our technical delivery specifications. If we have to deliver according to customer drawings, specifications, samples etc., the customer shall assume the risk for suitability for the intended purpose. If, after the contract is concluded, the scope of goods or services is changed at the customer's request and this impairs the quality or suitability of the goods, claims for defects on the part of the customer shall be ruled out, insofar as such impairments are caused by the customer's requests for change.

The time at which the risk is transferred is decisive for the contractual state of the goods. Wear and tear of wearing parts caused by ordinary use does not constitute a defect. Claims for defects are ruled out in the following cases in particular: Unsuitable or improper use, incorrect installation and/or commissioning by the customer or third party, normal wear and tear, incorrect or negligent handling - in particular excessive use -, unsuitable equipment, replacement materials, chemical, electrochemical or electrical influences, unless such defects are caused by ourselves.

If the goods contain a defects, we shall provide, following a reasonable period of grace set by the customer, either a replacement or a repair as we deem fit. If such subsequent performance fails, the customer shall be entitled to either reduce the purchase price or withdraw from the contract. Any further warranty claims are ruled out. In case of negligible deviations from the agreed quality, no claims for defects shall be recognised.

The discovery of defects must be communicated to us immediately in writing. In the case of recognisable defects, however, within 10 days of acceptance, in the case of non-recognisable defects immediately after they become evident. The warranty is 12 months, starting with delivery of the goods ex-works.

## 14. Liability

With the exception of harm to life, body or health on account of a breach of duty by ourselves, our liability shall be limited to intent or gross negligence.

## 15. Place of fulfilment, place of jurisdiction and governing law

The place of fulfilment for all obligations ensuing from this contractual relationship is D-70734 Fellbach.

The place of jurisdiction for all legal disputes ensuing from the contractual relationship is the court responsible for the headquarters of Andreas Maier GmbH & Co. KG.

All disputes ensuing from the contract or regarding the validity thereof shall be finally decided by a court of arbitration in accordance with the Court of Arbitration Ordinance of the German Committee for Arbitration Court Procedures or the Conciliation and Arbitration Arrangement of the International Chamber of Commerce, recourse to ordinary courts of law being excluded. The legal dunning process, however, remains permissible.

German law shall govern (BGB and HGB). The applicability of the UN Convention on Contracts for the International Sale of Goods (CISG) is ruled out.

## 16. Severability clause

If individual provisions become legally invalid, the remaining provisions shall not be affected. The legally invalid provision shall be replaced by regulations that most closely reflect the economic purpose of the contract with reasonable consideration for the mutual interests. The publication of these Terms of Sale, Delivery and Payment renders all previous versions invalid. This does not apply for any contracts concluded prior to announcement.

# MARKING AND CLEANING TOOLS CATALOGUE 2017/2018

Request additional catalogues from [www.amf.de](http://www.amf.de)

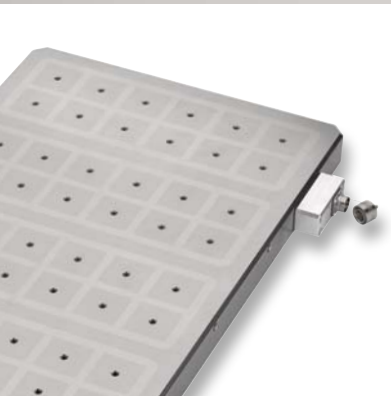

MAGNETIC CLAMPING SYSTEMS



HYDRAULIC CLAMPING SYSTEMS



„ZERO-POINT“ CLAMPING SYSTEM



MODULAR FIXTURE SYSTEMS

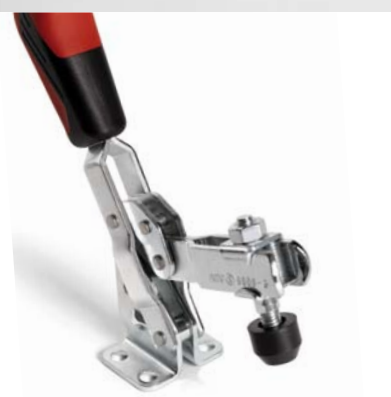

TOGGLE CLAMPS

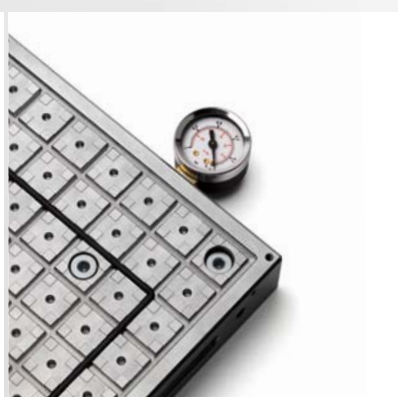

VACUUM CLAMPING SYSTEMS



STANDARD CLAMPING ELEMENTS

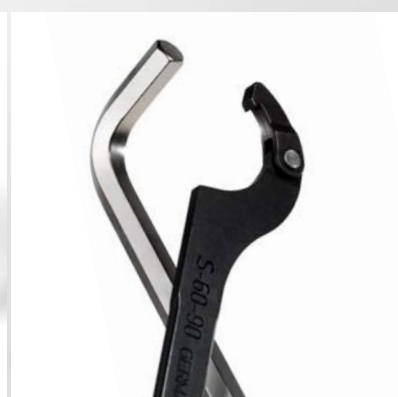

HAND TOOLS



MARKING AND CLEANING TOOLS

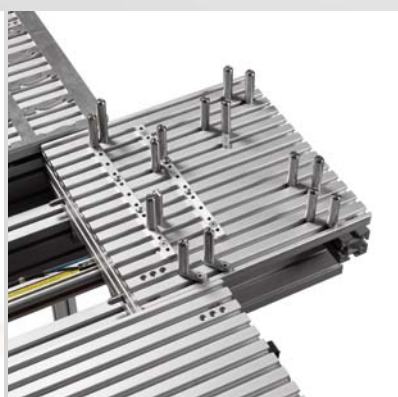

PALLET FEED SYSTEMS



GRIPPERS

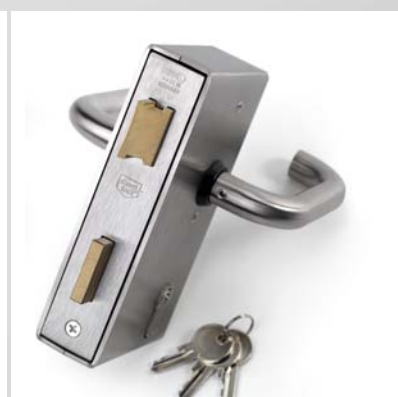

LOCKS FOR GATES AND DOORS



**ANDREAS MAIER GmbH & Co. KG**

Waiblinger Straße 116 · D-70734 Fellbach

Phone: +49 711 5766-0

Fax: +49 711 575725

E-mail: [amf@amf.de](mailto:amf@amf.de)

Web: [www.amf.de](http://www.amf.de)

Order no. 515429 · € 2,40