

No. 6204S4HA-002

4-point clamping station

Hydraulic unlocking.
Pneumatic blow-out.
Opening operating pressure: min. 50 bar - max. 60 bar.
Clamping modules' contact surface: Steel, stainless and hardened.
Base plate: Steel, unhardened.
Repetition accuracy < 0.005 mm.

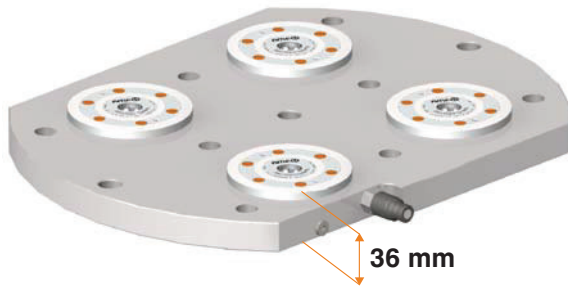

Order no.	Size	Pull-in/locking force up to [kN]	Holding force* [kN]	Blow out	Weight [Kg]
427492	K10.2	4 x 10	4 x 25	●	37

Design:

Hydraulic clamping station for optimised clamping times on machine tables with distance between slots of 63 mm. Clamping is with M12 socket head screws. At least two fitting holes are attached for alignment.

The insertion dimension of the clamping modules is 200 mm. The quick coupling plug is pre-mounted, and the integrated blow-out function can be individually connected.

Application:

e.g. for DMG / DMU 50 EVO

Advantage:

Low overall height of only 36 mm.

Note:

* Please observe the installation instructions.

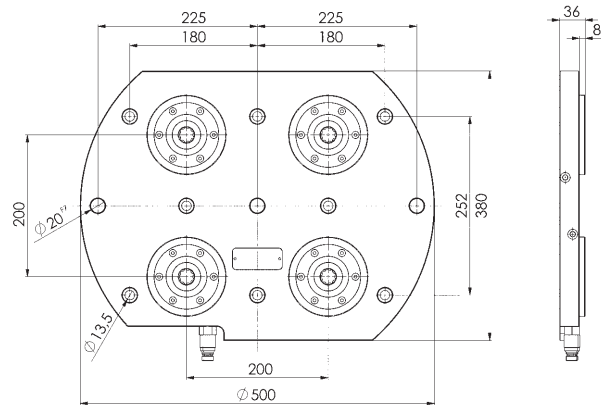

No. 6204S4HA-003

4-point clamping station

Hydraulic unlocking.
Pneumatic blow-out.
Opening operating pressure: min. 50 bar - max. 60 bar.
Clamping modules' contact surface: Steel, stainless and hardened.
Base plate: Steel, unhardened.
Repetition accuracy < 0.005 mm.

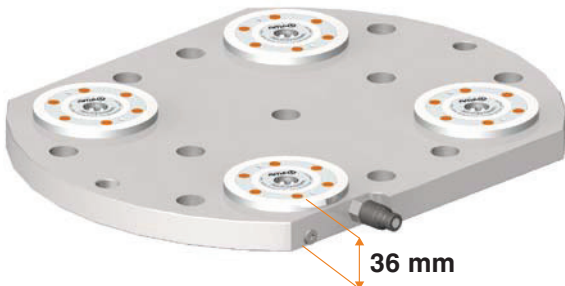

Order no.	Size	Pull-in/locking force up to [kN]	Holding force* [kN]	Blow out	Weight [Kg]
427518	K10.2	4 x 10	4 x 25	●	38

Design:

Hydraulic clamping station for optimised clamping times on machine tables with distance between slots of 80 mm. Clamping is with M16 socket head screws. At least two fitting holes are attached for alignment.

The insertion dimension of the clamping modules is 240 mm. The quick coupling plug is pre-mounted, and the integrated blow-out function can be individually connected.

Application:

e.g. for Mazak Variaxis 500

Advantage:

Low overall height of only 36 mm.

Note:

* Please observe the installation instructions.

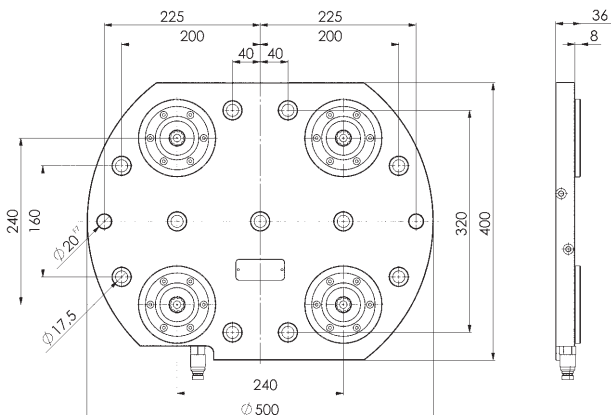

Subject to technical alterations.

No. 6204S6HA-002

6-point clamping station

Hydraulic unlocking.
 Pneumatic blow-out.
 Opening operating pressure: min. 50 bar - max. 60 bar.
 Clamping modules' contact surface: Steel, stainless and hardened.
 Base plate: Steel, unhardened.
 Repetition accuracy < 0.005 mm.

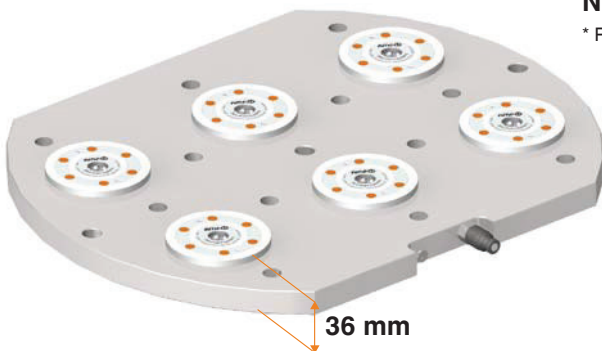

Order no.	Size	Pull-in/locking force up to [kN]	Holding force* [kN]	Blow out	Weight [Kg]
427534	K10.2	6 x 10	6 x 25	●	62

Design:

Hydraulic clamping station for optimised clamping times on machine tables with distance between slots of 63 mm. Clamping is with M12 socket head screws. At least two fitting holes are attached for alignment.
 The insertion dimension of the clamping modules is 200 mm. The quick coupling plug is pre-mounted, and the integrated blow-out function can be individually connected.

Application:

e.g. for DMG / DMU 50

Advantage:

Low overall height of only 36 mm.

Note:

* Please observe the installation instructions.

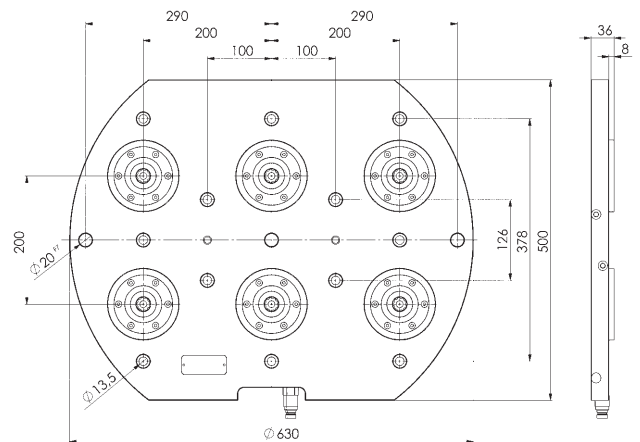

No. 6204S6HA-003

6-point clamping station

Hydraulic unlocking.
 Pneumatic blow-out.
 Opening operating pressure: min. 50 bar - max. 60 bar.
 Clamping modules' contact surface: Steel, stainless and hardened.
 Base plate: Steel, unhardened.
 Repetition accuracy < 0.005 mm.

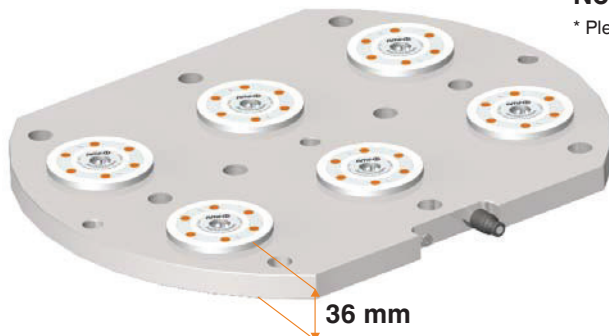

Order no.	Size	Pull-in/locking force up to [kN]	Holding force* [kN]	Blow out	Weight [Kg]
427559	K10.2	6 x 10	6 x 25	●	62

Design:

Hydraulic clamping station for optimised clamping times on machine tables with distance between slots of 100 mm. Clamping is with M16 socket head screws. At least two fitting holes are attached for alignment.
 The insertion dimension of the clamping modules is 200 mm. The quick coupling plug is pre-mounted, and the integrated blow-out function can be individually connected.

Application:

e.g. for Mazak Variaxis 630

Advantage:

Low overall height of only 36 mm.

Note:

* Please observe the installation instructions.

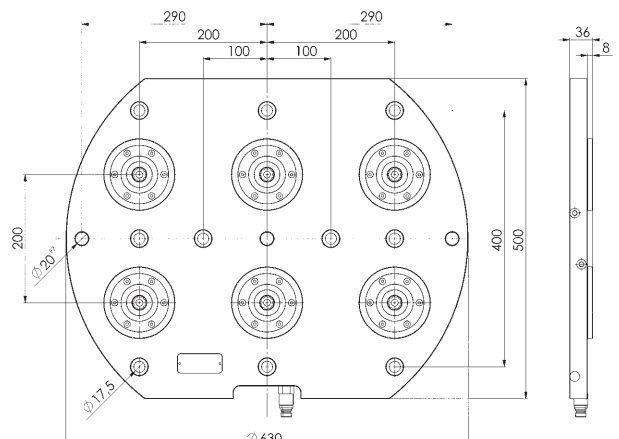

Subject to technical alterations.