

SCWT2 Series

外形尺寸图

● 基本型 (00)

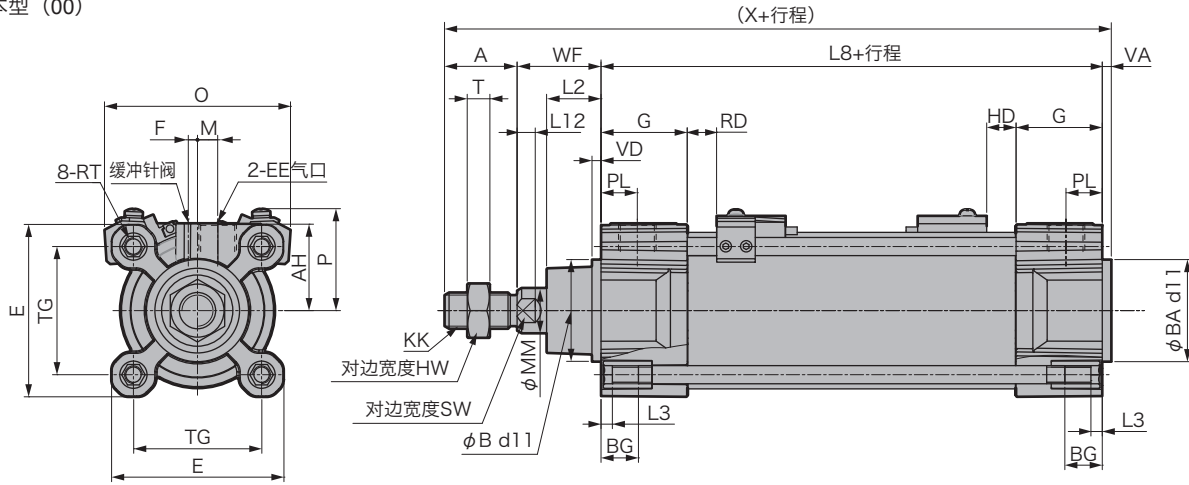

(单位: mm)

符号	基本型 (00) 基本尺寸																			
缸径	A	B/BA	BG	E	AH	EE	F	G	HW	KK	L2	L3	L8	L12	M	MM	SW	PL	RT	T
φ32	22	30	16	47.5	24.3	G1/8	-6.7	33	17	M10×1.25	15	5	94	6	4.9	12	10	13	M6	6
φ40	24	35	16	53	27	G1/4	-10	35.8	18	M12×1.25	17	5	105	8	5.5	16	13	14	M6	6
φ50	32	40	16	65	33	G1/4	0.6	37	24	M16×1.5	24	5	106	8	7	20	17	14	M8	10
φ63	32	45	16	76	38.5	G3/8	3	38.3	24	M16×1.5	24	5	121	8	9	20	17	16	M8	10
φ80	40	45	17	95	48	G3/8	0	40	30	M20×1.5	30	6	128	11	12	25	22	16	M10	12
φ100	40	55	17	114	57.5	G1/2	4.5	43.2	30	M20×1.5	33	6	138	11	12	25	22	18	M10	12

符号	带开关									
	T0, T5, T2, T3	T2W, T3W	RD	HD	RD	HD	RD	HD		
缸径	TG	VA/VD	WF	X	O	P	RD <td>HD <td>RD <td>HD</td> </td></td>	HD <td>RD <td>HD</td> </td>	RD <td>HD</td>	HD
φ32	32.5	4	26	146	58	38	4.5	4.5	7	7
φ40	38	4	30	163	64	40	4.5	9.5	7	12
φ50	46.5	4	37	179	72	42	5.5	7.5	8	9.5
φ63	56.5	4	37	194	83	46	10	15.5	12.5	17.5
φ80	72	4	46	218	103	56	14.5	14.5	17	17
φ100	89	4	51	233	120	63	16.5	16.5	18.5	18.5

● 轴向脚座型 (LB)

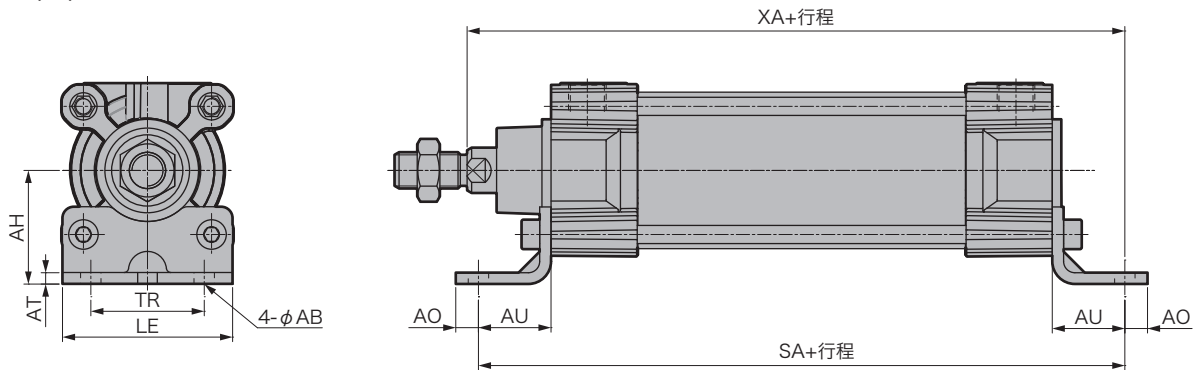

(单位: mm)

缸径	AB	AH	AO	AT	AU	LE	SA	TR	XA
φ32	7	32	8	4	24	46	142	32	144
φ40	9	36	10	4	28	52	161	36	163
φ50	9	45	10	5	32	65	170	45	175
φ63	9	50	10	5	32	75	185	50	190
φ80	12	63	13	6	41	94	210	63	215
φ100	14.5	71	15	6	41	114	220	75	230