

## Dimensions

### ● VSU fixing bracket

Unit: mm

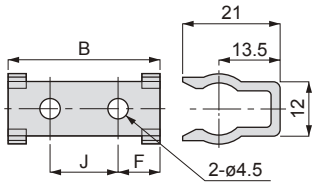

Model no.	B	F	J	Weight (g)
VSU-05-B	33.2	9	15	2
VSU-07-B	39.2	10	20	2

Note: VSU-05-B is for 0.5mm nozzle diameters and VSU-07-B is for 0.7mm nozzle diameters.

### Model no.

### ● Filter element

#### VSU-E

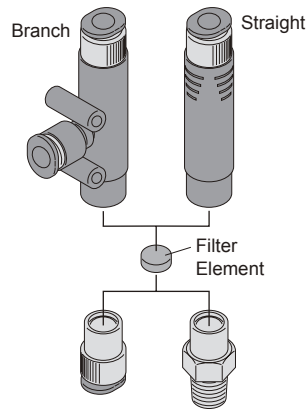

Ejector system

VSU

VSH-VSU  
VSB-VSC

VSG

VSK  
VSKM

VSJ  
VSJM

VSX  
VSXM

VSQ

VSZM