

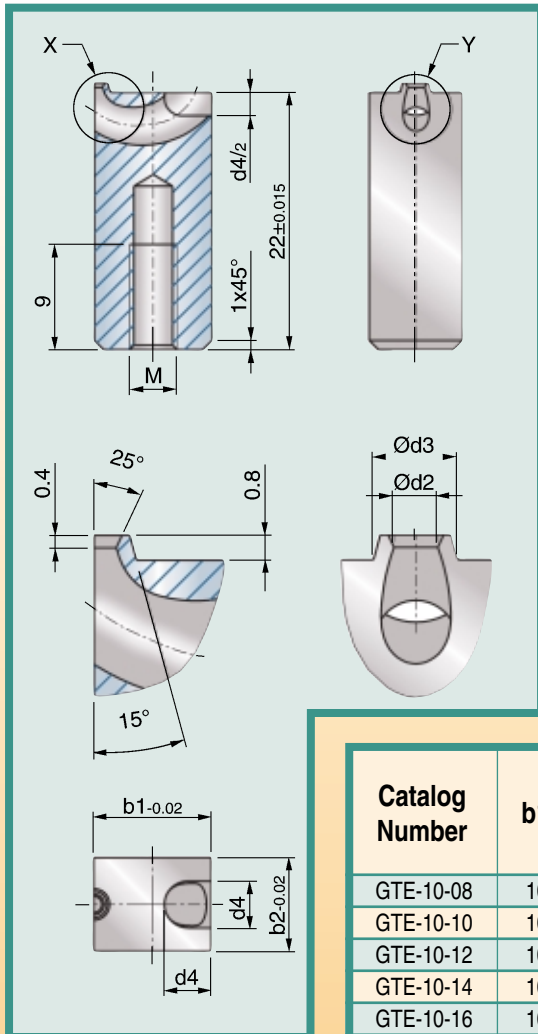

Cashew Gate Inserts

10mm

For shot weights up to 40g



Actual Size

External View

Cutaway View

- Manufactured in a solid one-piece unit using the Metal Injection Molding (MIM) process.
- Optimal balancing of cavity filling due to the exactness of MIM.
- Hardened to 60HRC and polished.
- Ideal for thin wall parts.

Catalog Number	b1	b2	d2	d3	d4	M	Viscosity		
							high flowability	regular flowability	low flowability
GTE-10-08	10	8	0,8	2,1	4	4	8	7	5
GTE-10-10	10	8	1,0	2,3	4	4	14	12	9
GTE-10-12	10	8	1,2	2,5	4	4	20	16	10
GTE-10-14	10	8	1,4	2,7	4	4	30	23	15
GTE-10-16	10	8	1,6	2,9	4	4	40	30	20

Weight in grams

Installation Example

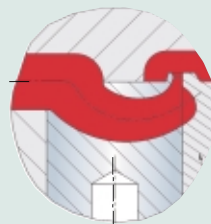
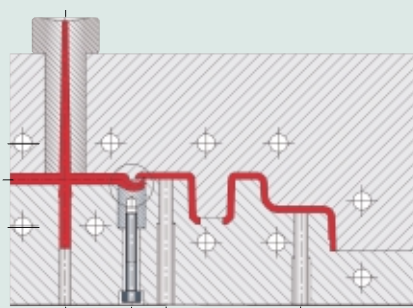

Standard Installation

The front of the cashew gate insert is sealed off by the mold cavity.

- to reduce pressure loss
- to avoid jetting

All inserts have the gate diameter 'd2' molded into them.

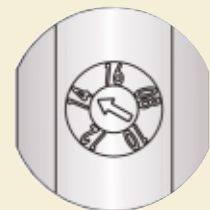

CAD files available at:
www.exaflow.com

