

# STUDS M4 TO M12

## WATER-COOLED

Item number example for a complete electrode



For threaded studs > M6



Change electrode SW 30 > 1111-ZK-22002



Centring sleeve, Volcera > 8440-ZK-13002



DOGLAS insert > 1115-ZK-13002



O-ring for stud insert > 1123-ZK-16437



Base electrode for MK2 fixing > 1111-ZK-20542



Cooling ring > 1113-ZK-19766

### Change electrodes

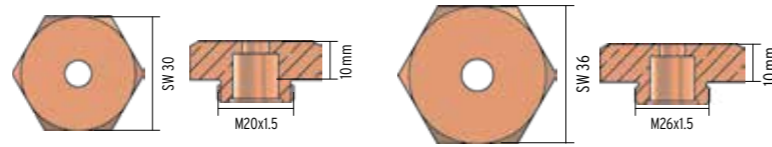

		SW30	SW36
Diameter	Item No.	1111-ZK-	1111-ZK-
	M4	22000	-
	M5	22001	-
	M6	22002	-
	M8	-	22003
	M10	-	22004
	M12	-	22005

### Centring sleeves



		Centring sleeve	
Screw thread	Item No.	8440-ZK-	8210-ZK-
	M4	13000	13000
	M5	13001	13001
	M6	13002	13002
	M8	13003	13003
	M10	13004	13004
	M12	13005	13005

### Accessories

#### DOGLAS insulating insert



		M4	M5	M6	M8	M10	M12
Ø D (mm)	Item No.	1115-ZK-	1115-ZK-	1115-ZK-	1115-ZK-	1115-ZK-	1115-ZK-
	16.8	13000	13001	13002	-	-	-
22.8	-	-	-	13003	13004	13005	-

#### O-rings for base electrode

		O-rings for base electrodes	
Ø (mm)	Item No.	1123-ZK-	
	28	16436	
	34	26187	

#### O-rings for stud insert

		O-rings for stud insert	
Ø (mm)	Item No.	1123-ZK-	
	M4 to M6	16437	
	M8 to M12	16438	

#### Compressed air connector

		Compressed air connector 1/8-6	
Item No.	1116-ZK-		
	12353		

### Base electrodes

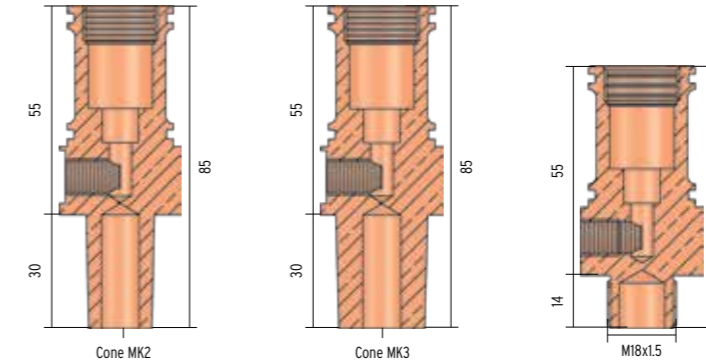

		Cone MK2	Cone MK3	Thread M18x1.5
Diameter	Item No.	1111-ZK-	1111-ZK-	1111-ZK-
	M4, M5, M6	20542	20543	20562
M8, M10, M12	20544	20545	20563	

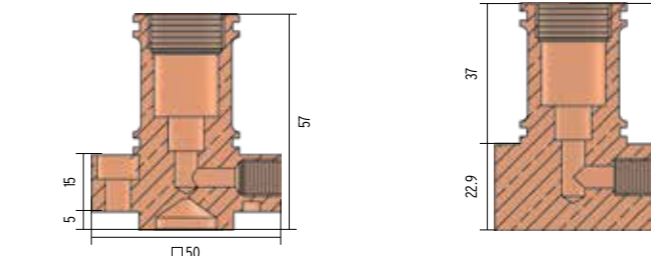

		R-type	C-type
Diameter	Item No.	1111-ZK-	1111-ZK-
	M4, M5, M6	20642	20662
M8, M10, M12	20644	20663	

### Cooling ring



		Cooling ring		
Screw thread	Item No.	1113-ZK-	1113-ZK-	1113-ZK-
	M4 to M6	19766	M8 to M12	19767
	C-type M4 to M6	19766	C-type M8 to M12	19769

Perfect stud and sheet centring with a sleeve made of VOLCERA

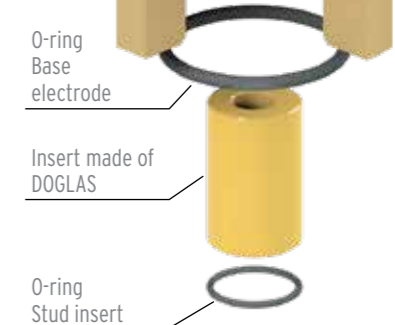
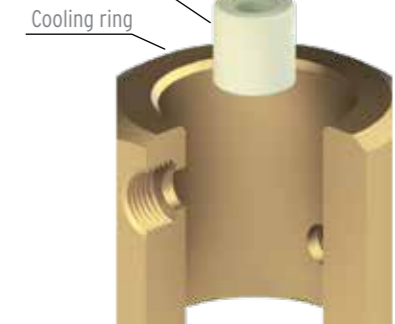
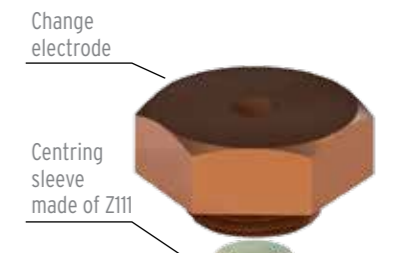

Compressed air connector (optional)