

LIQUID SOAP DISPENSER WP101



70 x 270 x 110 mm

500 ml soap bottle

- Liquid soap dispenser in robust, germ-reducing and easy-care stainless steel (AISI 316L).
- All-stainless steel housing; all corners fully welded, visible surfaces satin finished and brushed. Further available surfaces: see below.
- One-hand operated and non-drip soap pump.
- Designed for standard 500 ml bottles of liquid soap or hand lotion.
- Inspection slot to indicate fill level.
- Accessible for refilling through lockable, hinged housing.
- Keyed alike cylinder lock in corrosion-resistant zinc die-casting.
- Wear parts can be replaced as modules.
- Mounting: With two screws through key holes and one optional anti-theft hole in the back wall.
- Delivery includes fixing material and first fill with soap.
- Weight, including single package: 1.7 kg



Suggested text for specifications:

Liquid soap dispenser in stainless steel (AISI 316L) for surface mounting. All-stainless steel housing; all corners fully welded, visible surfaces satin finished and brushed. One-hand operated and non-drip soap pump. Designed for standard 500 ml bottles of liquid soap or hand lotion. Inspection slot to indicate fill level. Accessible for refilling through lockable, hinged housing. Keyed alike cylinder lock in corrosion-resistant zinc die-casting. Delivery includes fixing material and first fill with soap.

Dimensions: 70 x 270 x 110 mm

Article No. WP101

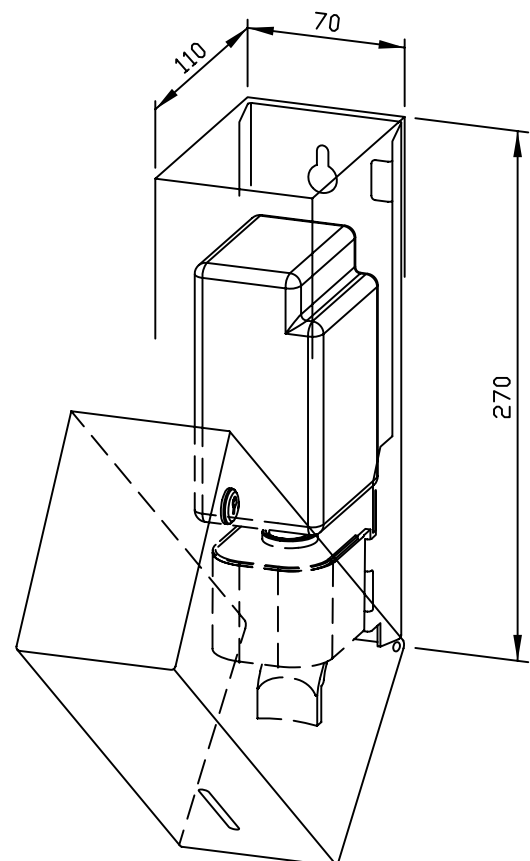

Available surfaces	ID No.
satin finished (standard)	727 301
highly polished	731 970
(coloured) plastic powder-coating	728 075

Ernst Wagner GmbH & Co. KG

Ernst-Abbe-Straße 21 · D-72770 Reutlingen · Tel.: +49712151539-0 · Fax: -20
info@wagner-ewar.de · www.wagner-ewar.de

WAGNER
EWAR