

SENSOR LIQUID SOAP DISPENSER WP102E-1



86 x 298 x 121 mm

850 ml plug-in tank

- Sensor liquid soap dispenser in robust, germ-reducing and easy-care stainless steel (AISI 316L).
- All-stainless steel housing; all corners fully welded, visible surfaces satin finished and brushed. Further available surfaces: see below.
- With EWAR® eModule touch-free operated and non-drip soap pump with 850 ml plug-in tank.
- Designed for standard liquid soaps or hand lotions.
- Inspection slot to indicate fill level.
- Accessible for refilling through lockable, hinged housing.
- Keyed alike cylinder lock in corrosion-resistant zinc die-casting.
- eModule battery-powered with two 1.5 V Baby/LR14 batteries. Power supply available as an option.
- Wear parts can be replaced as modules.
- Mounting: With three screws through key holes and one optional anti-theft hole in the back wall.
- Delivery includes fixing material and batteries.
- Weight, including single package: 1.8 kg

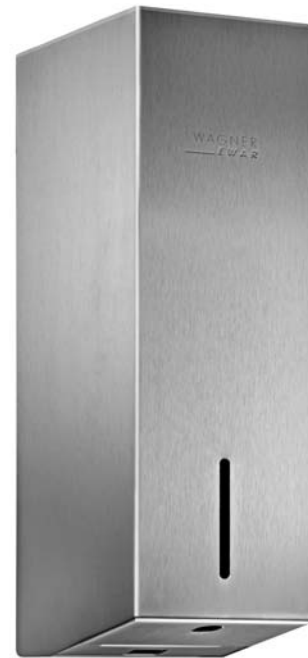

Suggested text for specifications:

Sensor liquid soap dispenser in stainless steel (AISI 316L) for surface mounting. All-stainless steel housing; all corners fully welded, visible surfaces satin finished and brushed. With touch-free operated and non-drip soap pump with 850 ml plug-in tank. Designed for standard liquid soaps or hand lotions. Inspection slot to indicate fill level. Accessible for refilling through lockable, hinged housing. Keyed alike cylinder lock in corrosion-resistant zinc die-casting. Delivery includes fixing material and batteries.

Dimensions: 86 x 298 x 121 mm

Article No. WP102e-1

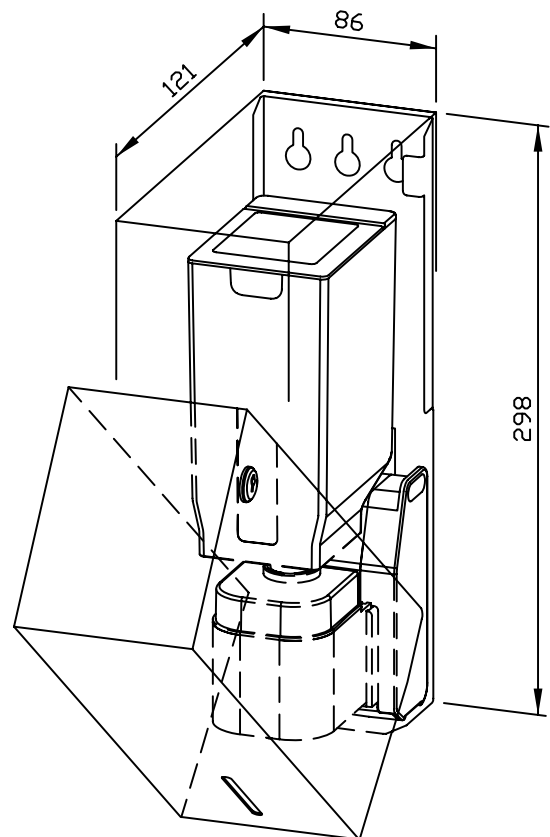

Options

ID No.

Power supply for eModule

923 060

Available surfaces

ID No.

satin finished (standard)

727 308

highly polished

731 308

(coloured) plastic powder-coating

728 308

Ernst Wagner GmbH & Co. KG

Ernst-Abbe-Straße 21 · D-72770 Reutlingen · Tel.: +49712151539-0 · Fax: -20
info@wagner-ewar.de · www.wagner-ewar.de

WAGNER
EWAR