

KALIP SETİ PRESLEME ÜNİTESİ - MANUEL

201.145.
201.149.

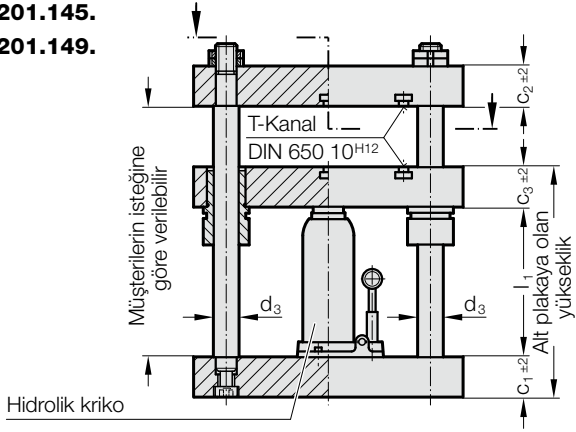

201.145.

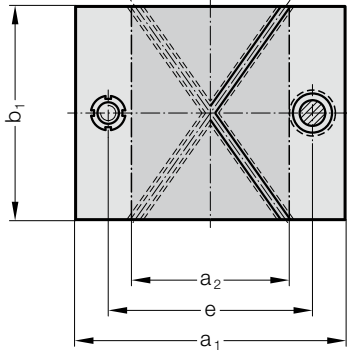

201.149.

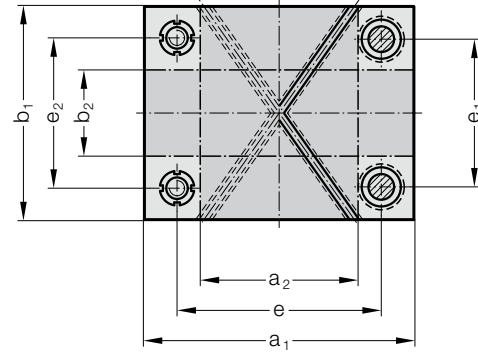

201.14x. Kalıp Seti Presleme Ünitesi - Manuel

| Sipariş No. | Çalışma Alanı | | Maks. Basınç | Kuvveti | a ₁ | b ₁ | c ₁ | c ₂ | c ₃ | d ₃ | e | e ₁ | e ₂ | l ₁ | strok _{maks.} |
|------------------------|---------------------------------|---------------------------------|--------------|---------|----------------|----------------|----------------|----------------|----------------|----------------|-----|----------------|----------------|----------------|------------------------|
| | a ₁ x b ₂ | a ₁ x b ₂ | | | | | | | | | | | | | |
| 201.14□.2020.□□□.□□□.□ | 84 x 200 | 200 x 62 | 20 | 200 | 200 | 32 | 32 | 32 | 25 | 132 | 132 | 129 | 200 | 130 | |
| 201.14□.2520.□□□.□□□.□ | 134 x 200 | 250 x 62 | 20 | 250 | 200 | 32 | 32 | 32 | 25 | 182 | 132 | 129 | 200 | 130 | |
| 201.14□.2525.□□□.□□□.□ | 118 x 250 | 250 x 97 | 40 | 250 | 250 | 40 | 40 | 40 | 32 | 174 | 174 | 171 | 200 | 130 | |
| 201.14□.3125.□□□.□□□.□ | 183 x 250 | 315 x 97 | 40 | 315 | 250 | 40 | 40 | 40 | 32 | 239 | 174 | 171 | 200 | 130 | |
| 201.14□.3131.□□□.□□□.□ | 283 x 315 | 315 x 162 | 40 | 315 | 315 | 40 | 40 | 40 | 32 | 239 | 239 | 236 | 200 | 130 | |
| 201.14□.4031.□□□.□□□.□ | 268 x 315 | 400 x 162 | 80 | 400 | 315 | 50 | 50 | 50 | 32 | 324 | 239 | 236 | 245 | 160 | |
| 201.14□.4040.□□□.□□□.□ | 268 x 400 | 400 x 247 | 80 | 400 | 400 | 50 | 50 | 50 | 32 | 324 | 324 | 321 | 245 | 160 | |

Sipariş numaraları prensibi:

201.14□.4031.□□□.□□□.1

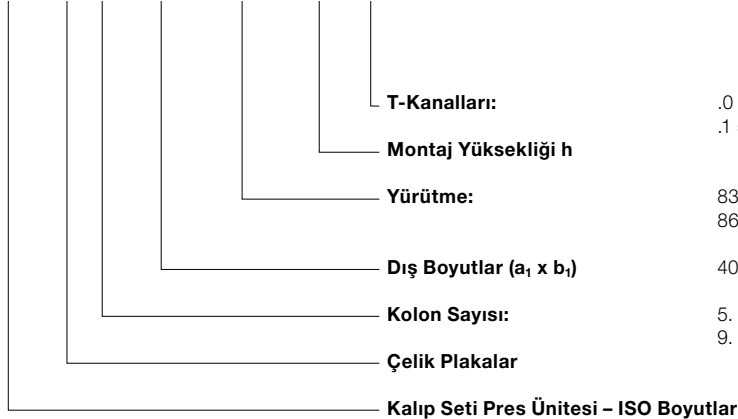

Yürütme: Şapkalı burç, hidrolik kriko

.0 = pimsiz
.1 = Üst Plaka ve Kılavuz Plakalarda

831. = Kılavuz Kolon (düz yataklı)
862. = Kılavuz Kolon (bilyalı burçla birlikte)

40: a₁ = 400 mm; 31: b₁ = 315 mm

5. = İki Kılavuz kolunlu
9. = Dört Kılavuz kolunlu