

SÄULENGESTELL DIN 9822 FORM C

201.31.

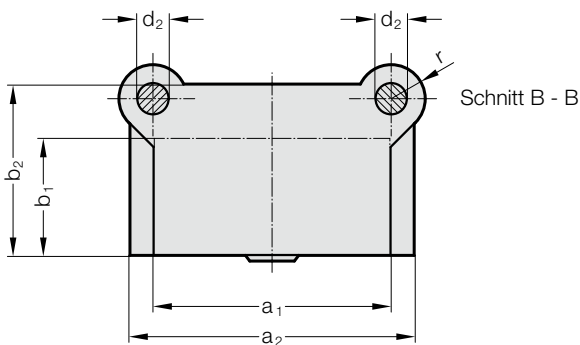
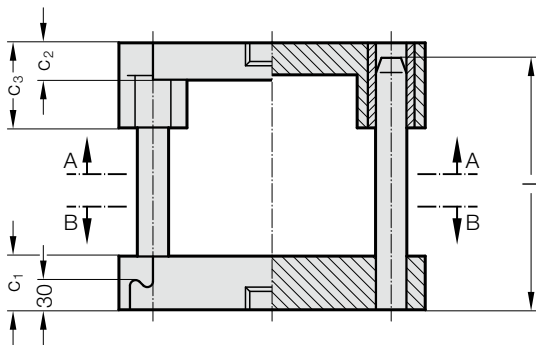
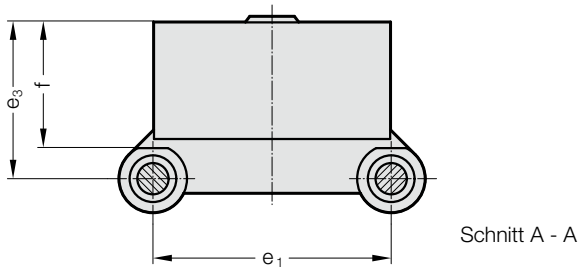

Führungsart

Sinterführung
carbonitriert

Kugelführung

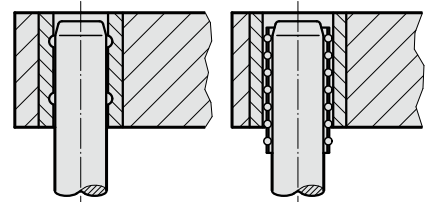

Bestell-Nr. Teil 2
Ohne Zapfengewinde
im Oberteil



201.31. Säulengestell DIN 9822 Form C

Bestell-Nummer Teil 1*	Arbeitsfläche											
	a ₁ x b ₁	a ₂	b ₂	c ₁	c ₂	c ₃	d ₂	e ₁	e ₃	f	l	r
201.31.063.050.□□□□□□	63 x 50	95	84	40	25	50	20	72	77	55	140 - 400	22
201.31.080.063.□□□□□□	80 x 63	125	105	45	30	60	20	80	92	68	160 - 400	27
201.31.100.063.□□□□□□	100 x 63	145	105	45	30	60	20	100	92	68	160 - 400	27
201.31.100.080.□□□□□□	100 x 80	145	130	50	30	70	25	100	112	87	160 - 500	30
201.31.125.080.□□□□□□	125 x 80	170	130	50	30	70	25	125	112	87	160 - 500	30
201.31.160.080.□□□□□□	160 x 80	205	130	50	30	70	25	160	112	87	160 - 500	30
201.31.125.100.□□□□□□	125 x 100	170	150	56	40	90	32	125	140	107	180 - 500	37
201.31.160.100.□□□□□□	160 x 100	205	150	56	40	90	32	160	140	107	180 - 500	37
201.31.200.100.□□□□□□	200 x 100	245	150	56	40	90	32	200	140	107	180 - 500	37
201.31.160.125.□□□□□□	160 x 125	215	180	56	40	90	32	160	165	132	180 - 500	37
201.31.200.125.□□□□□□	200 x 125	255	180	56	40	90	32	200	165	132	180 - 500	37
201.31.250.125.□□□□□□	250 x 125	305	180	56	40	90	32	250	165	132	180 - 500	37
201.31.200.160.□□□□□□	200 x 160	255	225	63	50	120	40	200	210	167	224 - 800	48
201.31.250.160.□□□□□□	250 x 160	305	225	63	50	120	40	250	210	167	224 - 800	48
201.31.250.200.□□□□□□	250 x 200	305	270	63	50	120	50	250	260	207	224 - 800	56
201.31.315.250.□□□□□□	315 x 250	370	320	63	50	120	50	315	310	257	224 - 800	56

*Bestell-Nummer Teil 2 = Führungsart und Führungssäulen-Typ/-Länge ergänzen
 Bestell-Beispiel siehe Anfang des Kapitels A Guss-Säulengestelle