

# 冲头，阶梯式，长孔，~ DIN 9861

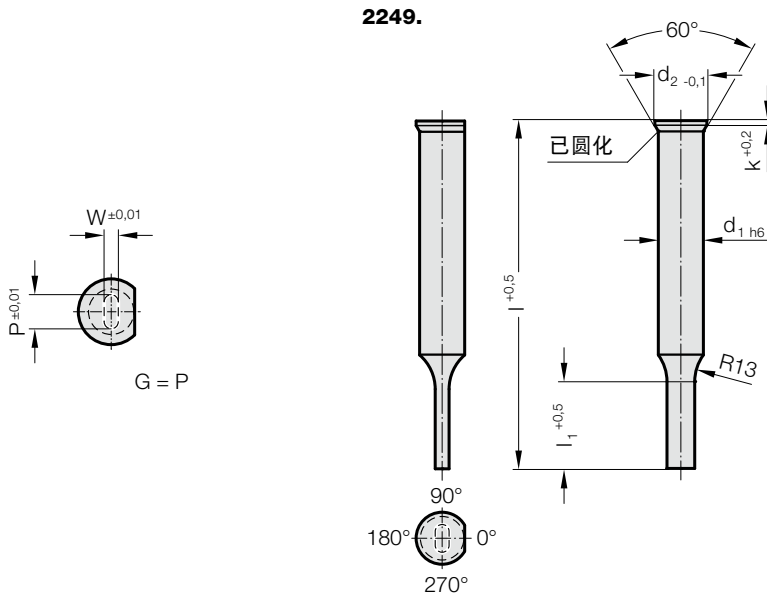

## 2249. 冲头，阶梯式，长孔，~ DIN 9861

d <sub>1</sub> / 订购数字	d <sub>2</sub>	W <sub>min</sub>	G <sub>max</sub>	l <sub>1</sub> / 订购数字	k	l (订货字母)	71 (D)	80 (E)	100 (G)	120 (J)
3 / (1)	4.5	0.5	2.9	8 (1) 10 (2)	0.5		●	●	●	●
4 / (2)	5.5	0.8	3.9	8 (1) 13 (3)	0.5		●	●	●	●
5 / (3)	6.5	1	4.9	13 (3) 19 (4)	0.5		●	●	●	●
6 / (4)	8	1.6	5.9	13 (3) 19 (4)	0.5		●	●	●	●
8 / (5)	10	2	7.9	19 (4) 25 (5)	1		●	●	●	●
10 / (6)	12	3.5	9.9	19 (4) 25 (5)	1		●	●	●	●
13 / (7)	15	4.5	12.9	19 (4) 25 (5)	1		●	●	●	●
16 / (8)	18	6	15.9	19 (4) 25 (5)	1.5		●	●	●	●
20 / (9)	22	8	19.9	19 (4) 25 (5)	1.5		●	●	●	●

订购示例:

**2 2 4 9 . 3 9 G 5 . 1 6 5 0 . 1 2 2 0 . B**

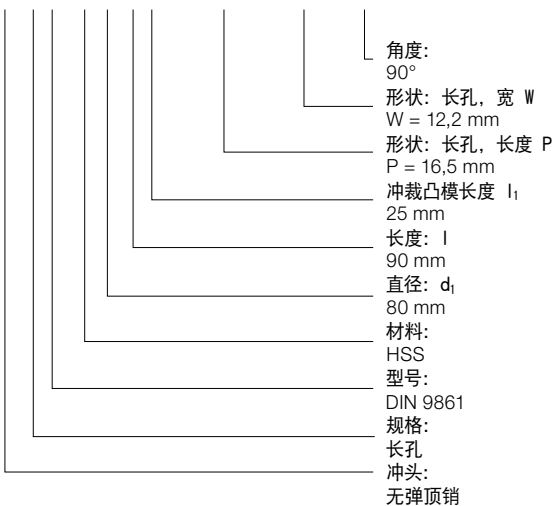

订货字母 = (B)  
 = 1220  
 = 1650  
 订购数字 = (5)  
 订货字母 = (G)  
 订购数字 = (9)  
 订购数字 = (3)  
 订购数字 = (9)  
 订购数字 = (4)  
 = 22

材料:

HSS

订货号 2249.3.

ASP 2023

订货号 2249.6.

硬度:

杆部 64 ± 2 HRC

头部 52 ± 5 HRC

☞ 材料说明和其他材料见E章开头。

结构:

切削冲头顶顶锻。接触面、轴杆及切削形状精密打磨。默认与尺寸 P = 0° 平行设计抗扭转面。

说明:

一起订购切削冲头和切削衬套时, 如果切削间隙 ≤ 0.04 mm, 则 FIBRO 会将尖角倒圆。借此, 缩短安装时间并降低运行时边缘断裂的风险。