

# CENTERING UNIT

2441.11.

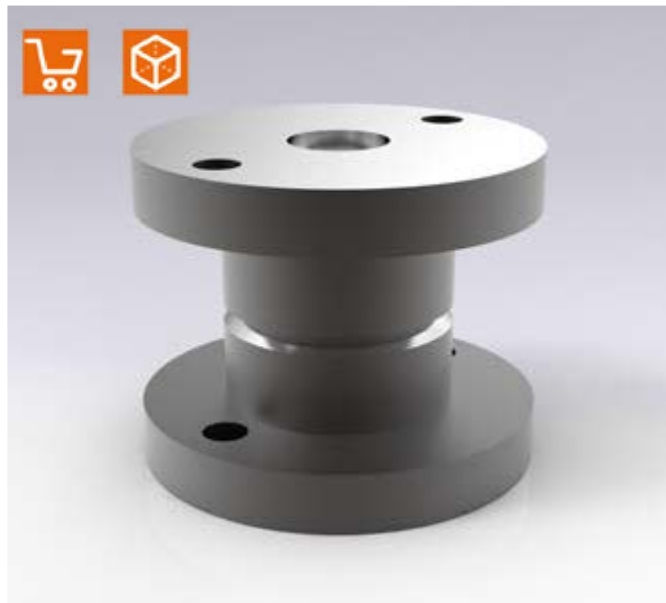
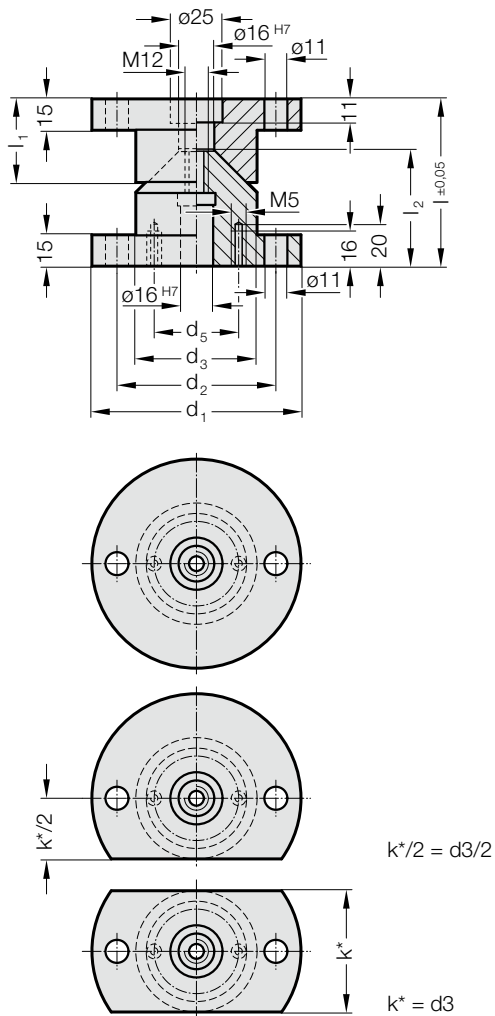

**Material:**

16MnCr5, tempered  
Case-hardened tapered surfaces  
Surface hardness: 60 + 4 HRC, EHT: 1.0 + 0.5 mm

**Note:**

Adjusting washer 2441.11.3. to be ordered separately.  
Screws are not included.

2441.11.□□□

Centering unit

2441.11.□□□.1

Centering unit with one flat side

2441.11.□□□.2

Centering unit with two flat sides

**2441.11. Centering unit**

Order No	d <sub>1</sub>	d <sub>2</sub>	d <sub>3</sub>	d <sub>5</sub>	l	l <sub>1</sub>	l <sub>2</sub>
2441.11.100	100	76	58	40.5	80	40	55
2441.11.100.1	100	76	58	40.5	80	40	55
2441.11.100.2	100	76	58	40.5	80	40	55
2441.11.120	120	96	78	50.5	90	50	65
2441.11.120.1	120	96	78	50.5	90	50	65
2441.11.120.2	120	96	78	50.5	90	50	65