

GAZLI YAY POWERLINE

Not:

180 bar da başlangıçtaki yay kuvveti = 320 daN

Yıpranmış yayları tamir etmeyiniz; bu yayların komple değiştirilmesi gerekmektedir.

Kullanılan gaz: Nitrojen – N₂
Maks. dolum basıncı: 180 bar
Min. dolum basıncı: 25 bar
Çalışma sıcaklığı: 0°C / +80°C
Sıcaklığa bağlı Kuvvet artışı: ± 0,3%/°C
Önerilen Strok/dk.:
yaklaşık 40 ila 100 arası (20°C de)
Maks. piston hızı: 1,6 m/s

2487.12.00320.

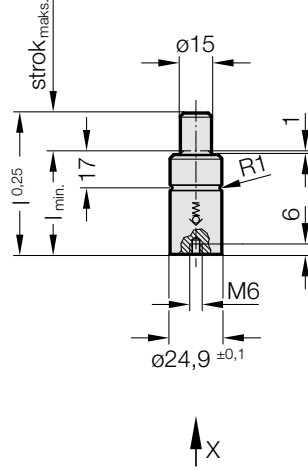

Görünüm X

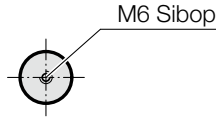

2487.12.00320.

Gazlı Yay POWERLINE

Sipariş No.	strok _{maks.} (s)	l _{min.}	l
2487.12.00320.007	7	37	44
2487.12.00320.010	10	40	50
2487.12.00320.015	15	45	60
2487.12.00320.019	19	49	68
2487.12.00320.025	25	55	80
2487.12.00320.038	38	68	106
2487.12.00320.050	50	80	130
2487.12.00320.063	63	93	156
2487.12.00320.075	75	110	185
2487.12.00320.080	80	115	195
2487.12.00320.100	100	135	235
2487.12.00320.125	125	160	285

Yay başlangıç kuvveti/Basınç miktarı

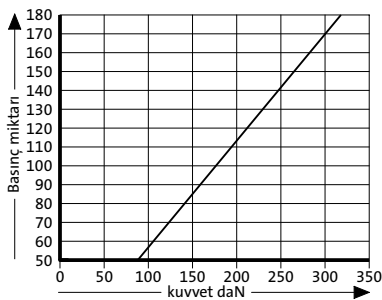

Yay kuvveti yer değişimi/Kurs artışı

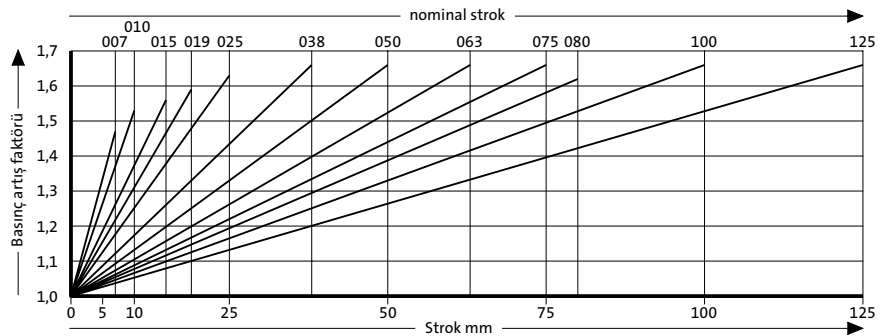

Basınç artış faktörü yer değişimini hesaba katar fakat dış etkenleri göz önünde bulundurmaz!