

GAZLI YAY POWERLINE

Not:

180 bar da başlangıçtaki yay kuvveti = 350 daN

Yedek parçalar için sipariş kodu:
2487.12.00350

Valfsiz gazlı yay
Sipariş No (örnek): 2487.12.00350. .P

Kullanılan gaz: Nitrojen – N₂
Maks. dolum basıncı: 180 bar
Min. dolum basıncı: 25 bar
Çalışma sıcaklığı: 0°C / +80°C
Sıcaklığa bağlı Kuvvet artışı: ± 0,3%/°C
Önerilen Strok/dk.:
yaklaşık 20 ila 100 arası (20°C de)
Maks. piston hızı: 1,6 m/s

2487.12.00350.

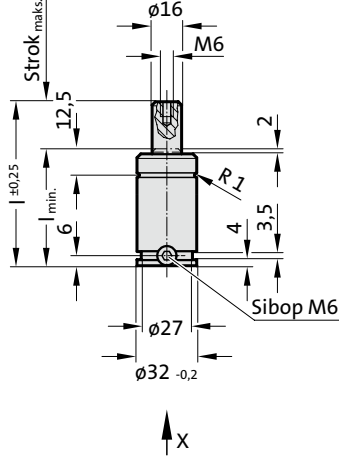

Görünüm X

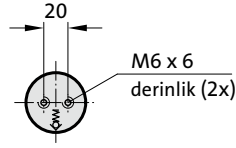

2487.12.00350.

Gazlı Yay POWERLINE

| Sipariş No. | strok _{maks.} (s) | l _{min.} | l |
|-------------------|----------------------------|-------------------|-----|
| 2487.12.00350.010 | 10 | 40 | 50 |
| 2487.12.00350.013 | 13 | 43 | 56 |
| 2487.12.00350.016 | 16 | 46 | 62 |
| 2487.12.00350.019 | 19 | 49 | 68 |
| 2487.12.00350.025 | 25 | 55 | 80 |
| 2487.12.00350.032 | 32 | 62 | 94 |
| 2487.12.00350.038 | 38 | 68 | 106 |
| 2487.12.00350.050 | 50 | 80 | 130 |
| 2487.12.00350.063 | 63 | 93 | 156 |
| 2487.12.00350.075 | 75 | 105 | 180 |
| 2487.12.00350.080 | 80 | 110 | 190 |
| 2487.12.00350.100 | 100 | 130 | 230 |
| 2487.12.00350.125 | 125 | 155 | 280 |

Yay başlangıç kuvveti/Basınç miktarı

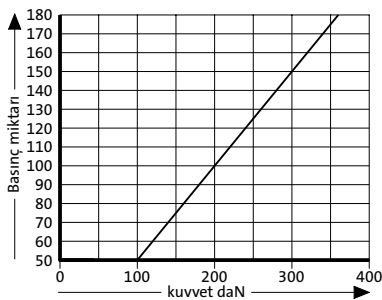

Yay kuvveti yer değişimi/Kurs artışı

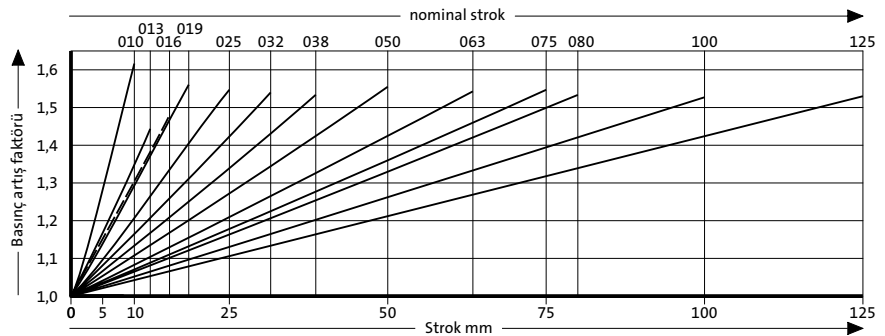

Basınç artış faktörü yer değişimini hesaba katar fakat dış etkenleri göz önünde bulundurmaz!