

# GAZLI YAY POWERLINE

## Not:

150 bar da başlangıçtaki yay kuvveti = 470 daN

Yedek parçalar için sipariş kodu:  
2487.12.00500

Valfsiz gazlı yay  
Sipariş No (örnek): 2487.12.00500. .P

Kullanılan gaz: Nitrojen – N<sub>2</sub>  
Maks. dolum basıncı: 150 bar  
Min. dolum basıncı: 25 bar  
Çalışma sıcaklığı: 0°C / +80°C  
Sıcaklığa bağlı Kuvvet artışı: ± 0,3%/°C  
Önerilen Strok/dk.:  
yaklaşık 20 ila 100 arası (20°C de)  
Maks. piston hızı: 1,6 m/s

2487.12.00500.

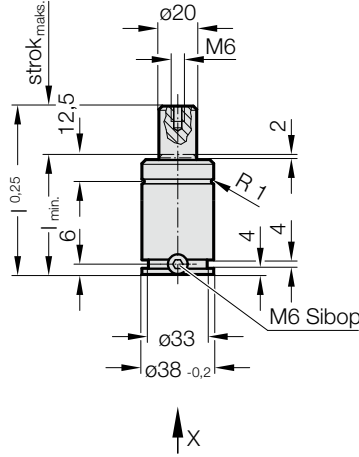

Görünüm X

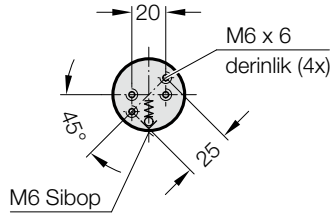

2487.12.00500.

## Gazlı Yay POWERLINE

Sipariş No.	strok <sub>maks.</sub> (s)	l <sub>min.</sub>	l
2487.12.00500.010	10	40	50
2487.12.00500.013	13	43	56
2487.12.00500.016	16	46	62
2487.12.00500.019	19	49	68
2487.12.00500.025	25	55	80
2487.12.00500.032	32	62	94
2487.12.00500.038	38	68	106
2487.12.00500.050	50	80	130
2487.12.00500.063	63	93	156
2487.12.00500.075	75	105	180
2487.12.00500.080	80	110	190
2487.12.00500.100	100	130	230
2487.12.00500.125	125	155	280

## Yay başlangıç kuvveti/Basınç miktarı

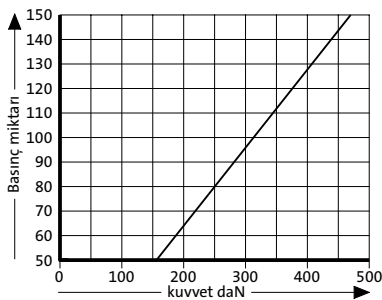

## Yay kuvveti yer değişimi/Kurs artışı

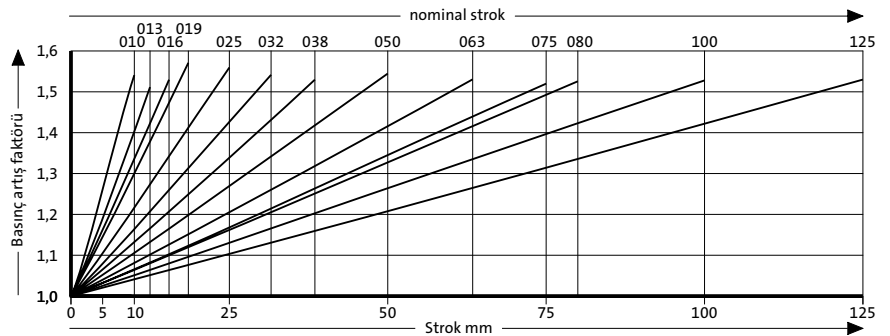

Basınç artış faktörü yer değişimini hesaba katar fakat dış etkenleri göz önünde bulundurmaz!