

# Rod Ends Series E - Maintenance Free

## Series EI..D (-2RS)

Rod Ends with female thread made from free-cutting or heat-treated steel, zinc plated with maintenance free Spherical Plain Bearings

For use at high uni-directional loads and limited fitting dimensions

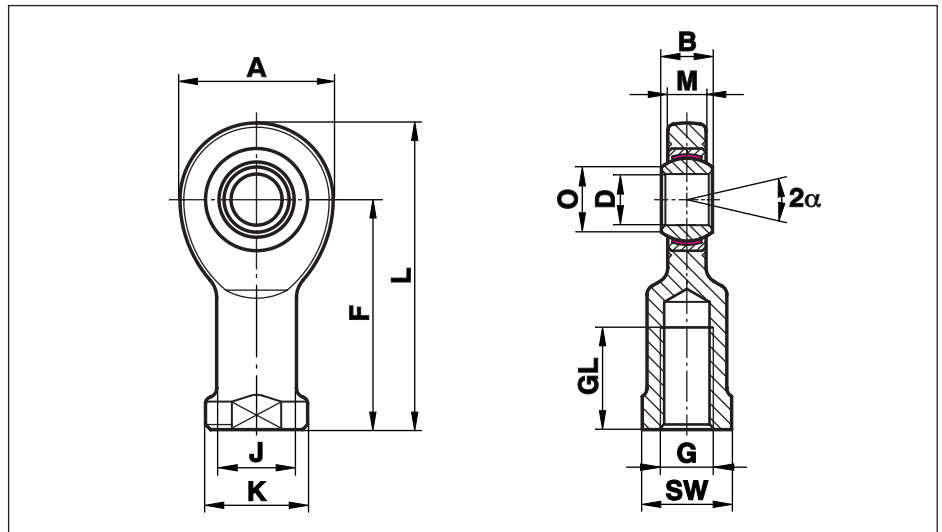

Size (D)	B	M	A	F	L	K	J	O	SW	G	GL	Static load C <sub>0</sub> kN	Dynamic load C kN	Pivoting angle	Weight g
6	6	4,4	20	30	40,0	13	10,0	8,0	11	M 6	12	10,3	3,6	13	21
8	8	6,0	24	36	48,0	16	12,5	10,2	14	M 8	16	15,8	5,8	15	38
10	9	7,0	28	43	57,0	19	15,0	13,2	17	M 10	20	23,4	8,6	12	60
12	10	8,0	34	50	67,0	22	17,5	14,9	19	M 12	22	31,0	11,5	11	96
15	12	10,0	40	61	81,0	26	21,0	18,4	22	M 14	29	42,5	17,5	8	180
16	14	11,0	46	67	90,0	30	24,0	20,7	27	M 16	33	54,5	22,5	10	220
17	14	11,0	46	67	90,0	30	24,0	20,7	27	M 16	33	54,5	22,5	10	220
20	16	13,0	53	77	103,5	35	27,5	24,2	32	M 20x1,5	38	62,5	31,5	9	350
25	20	17,0	64	94	126,0	42	33,5	29,3	36	M 24x2	48	92,0	51,0	7	640
30	22	19,0	73	110	146,5	50	40,0	34,2	41	M 30x2	56	124,0	66,0	6	930
35	25	21,0	82	125	166,0	58	47,0	39,8	50	M 36x3	60	144,0	140,0	6	1300
40	28	23,0	92	142	188,0	65	52,0	45,0	55	M 39x3	65	178,0	185,0	7	2000
45	32	27,0	102	145	196,0	70	58,0	50,8	60	M 42x3	65	263,0	240,0	7	2500
50	35	30,0	112	160	216,0	75	62,0	56,0	65	M 45x3	68	320,0	295,0	6	3500
60	44	38,0	135	175	242,5	88	70,0	66,8	75	M 52x3	70	497,0	460,0	6	5550
70	49	42,0	160	200	280,0	98	80,0	77,9	85	M 56x4	80	606,0	590,0	6	8600
80	55	47,0	180	230	320,0	110	95,0	89,4	100	M 64x4	85	752,0	750,0	6	12000

### Materials:

Housing: up to size 10 turned, from free-cutting steel to 9SMnPb28K, 12L13, from size 12 forged, from heat-treated steel to C45, Aisi 1045

Bearing: maintenance free steel/PTFE bearing GE...EC (see page 48), from size 20 available sealed from both sides (-2RS), from size 35 only available sealed from both sides (-2RS)