

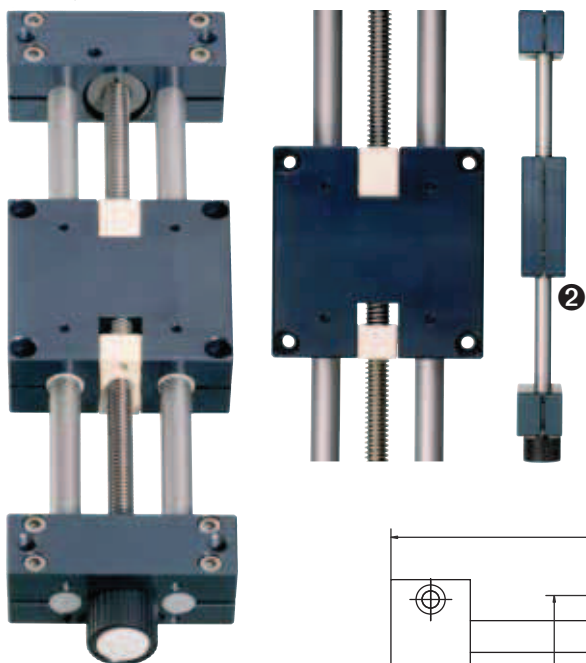

DryLin® SHT-PL | Adjustable clearance

Properties

- Lubricant-free
- Preloaded trapezoidal lead screw nut, Pretension force 50 N
- Radial clearance is adjustable
- Low weight



Preloaded trapezoidal lead screw nut

- ② Radial clearance adjustable from both sides

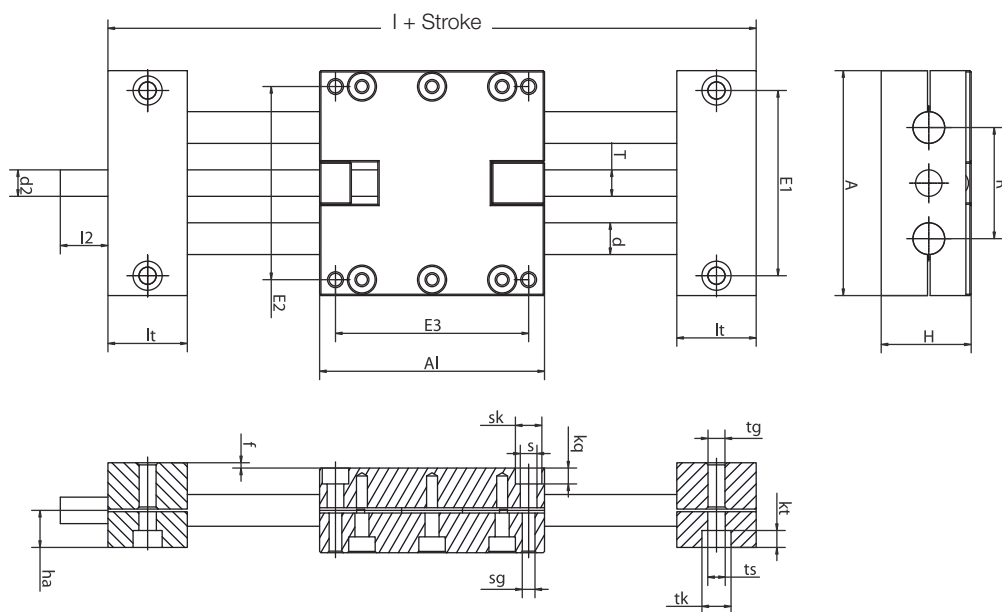

Lengths [mm] and Weight

Part No.	Maximum Stroke length [mm]	Aluminium Shaft		Steel Shaft		Max. static load-bearing capacity	
		Weight [kg]	Additional weight (per 100 mm) [kg]	Weight [kg]	Additional weight (per 100 mm) [kg]	axial [N]	radial [N]
SHT-12-AWM-PL	750	1,1	0,1	1,3	0,2	700	2800
SHT-20-AWM-PL	1000	3,2	0,3	3,9	0,6	1600	6400
SHT-30-AWM-PL	1250	8,6	0,6	10,9	1,4	2500	10000

Dimensions [mm]

Part No.	A	A1	H	E1	E2	E3	I	R	f	lt	tk	ts
	-0,3	-0,3		±0,15	±0,15	±0,15				±0,1		
SHT-12-AWM-PL	85	85	34	70	73	73	145	42	2	30	11	6,6
SHT-20-AWM-PL	130	130	48	108	115	115	202	72	2	36	15	9,0
SHT-30-AWM-PL	180	180	68	150	158	158	280	96	4	50	20	13,5

Part No.	tg	kt	s	sk	sg	kq	d	T	l2	d2	ha
		±0,1								Standard	
SHT-12-AWM-PL	M8	6,4	6,3	10	M6	6,0	12	TR10x2	17	TR10x2*	18
SHT-20-AWM-PL	M10	8,6	6,4	11	M8	7,0	20	TR18x4	26	12 h9	23
SHT-30-AWM-PL	M16	12,6	11,0	18	M12	10,6	30	TR24x5	38	14 h9	36

* TR10x2 leadscrew end unmachined



Order example:
More details on part no. options: ► Page 66.2

Phone +49 - 22 03 - 96 49-145
Fax +49 - 22 03 - 96 49-334

igus® GmbH
51147 Cologne

Internet www.igus.de
E-mail info@igus.de

mm

DryLin® SHT