



WSQ-06

WSQ-10

WSQ-16

WSQ-20

WSQ-25

**i** Hard-anodised surfaces  
▶ Page 43

**o** Curved rail profiles  
▶ Page 48

Technical data and dimensions [mm]

Part No.	Weight [kg/m]	H <sup>57)</sup>		L	a	h	h1	h2	G1	G2	A1	Q1	Q2
		±0.25	-0.1										
WSQ-06	0.23	14	5.0	3,000	14	4.0	4.0 <sup>58)</sup>	7.5	18.0	10.5	13.5	17.0	15
WSQ-10	0.54	20	7.5	4,000	25	5.5	5.5 <sup>58)</sup>	11.0	27.0	17.0	18.5	26.0	21
WSQ-16	0.94	27	11.5	4,000	27	7.5	3.5	14.0	33.0	19.0	25.0	32.0	28
WSQ-20	1.41	36	15.0	4,000	27	9.5	4.5	20.0	38.0	21.0	30.0	37.0	37
WSQ-25	1.94	45	18.5	4,000	32	11.5	5.5	25.0	46.5	25.5	37.5	45.5	46

Standard hole pattern: C5 = C6, please order with drawing for C5 ≠ C6

<sup>57)</sup> Height dimension minus the bearing clearance tolerance

<sup>58)</sup> Plain holes

Can be combined with:



WJ200QM-...

**o** Order key - single rail

Type Length

WSQ-06-□

Guide rail	Square	Shafts Ø	Rail length [mm]
------------	--------	----------	------------------

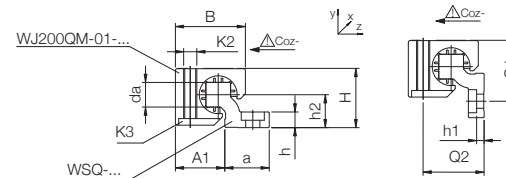
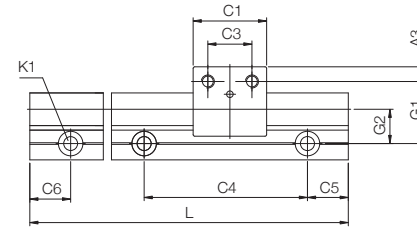

Part No.	C4	C5 min.	C5 max.	C6 min.	C6 max.	K1 for screw DIN 912	Geometrical moment of inertia		Moment of resistance	
							ly [mm <sup>2</sup> ]	lz [mm <sup>2</sup> ]	Wby [mm <sup>3</sup> ]	Wbz [mm <sup>3</sup> ]
WSQ-06	60	20	49.5	20	49.5	M4 <sup>58)</sup>	2,200	640	220	100
WSQ-10	120	20	79.5	20	79.5	M6 <sup>58)</sup>	16,100	3,300	950	350
WSQ-16	120	20	79.5	20	79.5	M8	33,000	10,800	1,700	910
WSQ-20	120	20	79.5	20	79.5	M8	56,500	34,000	2,600	2,100
WSQ-25	150	25	99.5	25	99.5	M10	115,900	73,500	4,500	3,700



Order key - pillow block

Type  Size

## WJ200QM-01-10

drylin® W  
Liner material  
iglidur® J200  
Pillow block,  
square  
Standard  
Size

- Options:  
**Blank:** Fixed bearing  
**LLY:** Floating bearing in y-direction  
**LLZ:** Floating bearing in z-direction  
**AL:** Pillow block made from aluminium

Suitable mounting plate  
▶ Page 130

### Technical data and dimensions [mm]

Part No.	Floating bearing clearance	Floating bearing direction	Weight [g]	-AL	B	C1	C3	A3	K2	K3 for countersunk head screw	Static load capacity		
											Coy [N]	Coz+ [N]	Coz- [N]
WJ200QM-01-06	-	-	16	7	18.0	19	10	4.5	M4	M3	420	420	140
WJ200QM-01-06-AL	-	-	16	7	18.0	19	10	4.5	M4	M3	420	420	140
WJ200QM-01-06-LLY	± 0.5	y / z	16	7	18.0	19	10	4.5	M4	M3	420	420	140
WJ200QM-01-06-LLZ	± 0.5	y / z	16	7	18.0	19	10	4.5	M4	M3	420	420	140
WJ200QM-01-10	-	-	41	21	26.0	29	16	6.5	M6	M5	1,200	1,200	250
WJ200QM-01-10-AL	-	-	41	21	26.0	29	16	6.5	M6	M5	1,200	1,200	250
WJ200QM-01-10-LLY	± 0.7	y / z	41	21	26.0	29	16	6.5	M6	M5	1,200	1,200	250
WJ200QM-01-10-LLZ	± 0.7	y / z	41	21	26.0	29	16	6.5	M6	M5	1,200	1,200	250
WJ200QM-01-16	-	-	100	51	34.5	36	18	9.0	M8	M6	2,100	2,100	400
WJ200QM-01-16-AL	-	-	100	51	34.5	36	18	9.0	M8	M6	2,100	2,100	400
WJ200QM-01-16-LLY	± 1.0	y / z	100	51	34.5	36	18	9.0	M8	M6	2,100	2,100	400
WJ200QM-01-16-LLZ	± 1.0	y / z	100	51	34.5	36	18	9.0	M8	M6	2,100	2,100	400
WJ200QM-01-20	-	-	190	104	42.5	45	27	9.0	M8	M6	3,200	3,200	500
WJ200QM-01-20-AL	-	-	190	104	42.5	45	27	9.0	M8	M6	3,200	3,200	500
WJ200QM-01-20-LLY	± 1.0	y / z	190	104	42.5	45	27	9.0	M8	M6	3,200	3,200	500
WJ200QM-01-20-LLZ	± 1.0	y / z	190	104	42.5	45	27	9.0	M8	M6	3,200	3,200	500
WJ200QM-01-25	-	-	435	212	52.5	58	36	11.0	M10	M8	4,800	4,800	950
WJ200QM-01-25-AL	-	-	435	212	52.5	58	36	11.0	M10	M8	4,800	4,800	950
WJ200QM-01-25-LLY	± 1.0	y / z	435	212	52.5	58	36	11.0	M10	M8	4,800	4,800	950
WJ200QM-01-25-LLZ	± 1.0	y / z	435	212	52.5	58	36	11.0	M10	M8	4,800	4,800	950

Order example: WJ200QM-01-06: Pillow block, square  
WJ200QM-01-06-LLZ: Pillow block, square, with floating bearing in z-direction  
WJ200QM-01-06-AL: Pillow block, square, made from aluminium

Can be combined with:



Order key - pillow block

Type  Size

## WJ200QM S-01-10-AL

drylin® W  
Liner material  
iglidur® J200  
Pillow block,  
square  
Narrow  
Standard  
Size  
Aluminium

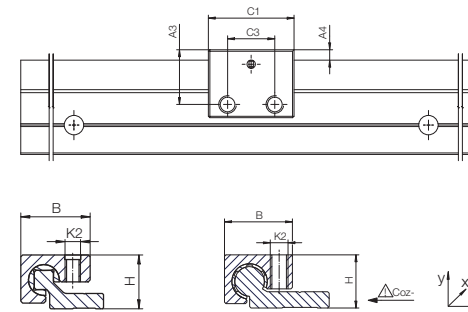

### Technical data and dimensions [mm]

Part No.	Weight [g]	B	C1	C3	A3	A4	K2	H ±0.25	Static load capacity		
									Coy [N]	Coz+ [N]	Coz- [N]
WJ200QMS-01-06-AL <b>New</b>	6.3	18	19	10	13.5	3.50	M4	14	210	140	210
WJ200QMS-01-10-AL <b>New</b>	17.1	23	29	16	18.5	4.75	M6	20	600	250	600
WJ200QMS-01-16-AL <b>New</b>	43.1	35	36	18	28.5	7.25	M8	27	1,050	400	1,050
WJ200QMS-01-20-AL <b>New</b>	90.1	42	45	27	35.0	9.00	M8	36	1,600	500	1,600
WJ200QMS-01-25-AL <b>New</b>	182.4	52	58	36	43.0	10.75	M10	45	2,400	950	2,400

Can be combined with:

