

Special properties

- Material: aluminium
- Available from stock

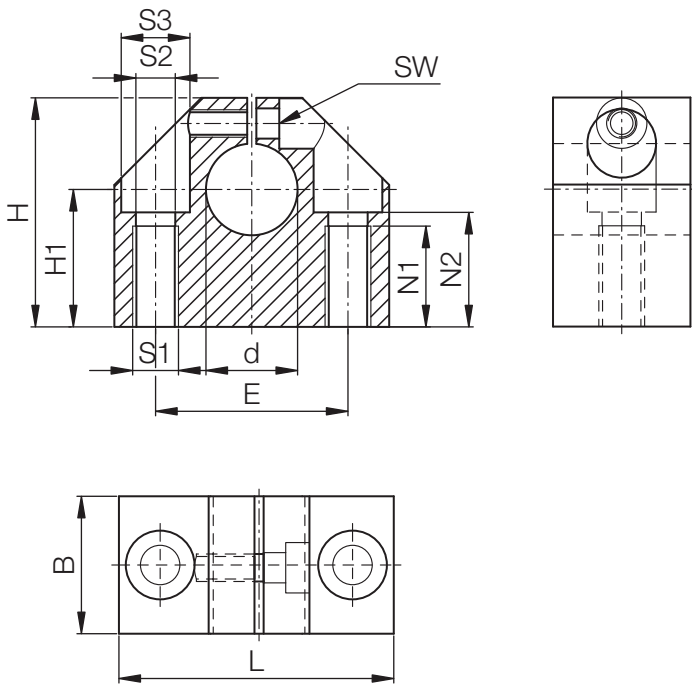

DryLin® Shafts
mm

Phone +49 - 22 03 - 96 49-145
Fax +49 - 22 03 - 96 49-334

Dimensions [mm]

Part No.	d [mm]	B [mm]	H [mm]	H1 [mm]	L [mm]	S1	S2 [mm]	S3 [mm]	E [mm]	N1 [mm]	N2 [mm]	SW [mm]	Weight [kg]
				±0,01					±0,12				
WAC-06*	6	16	27	15	32	M5	4,2	8	22	11	13	2,5	0,03
WAC-08	8	16	27	16	32	M5	4,2	8	22	11	13	2,5	0,03
WAC-10	10	18	33	18	40	M6	5,2	10	27	13	16	3,0	0,05
WAC-12	12	18	33	19	40	M6	5,2	10	27	13	16	3,0	0,05
WAC-14*	14	20	38	20	45	M6	5,2	10	32	13	18	3,0	0,07
WAC-16	16	20	38	22	45	M6	5,2	10	32	13	18	3,0	0,07
WAC-20	20	24	45	25	53	M8	6,8	11	39	18	22	4,0	0,12
WAC-25	25	28	54	31	62	M10	8,6	15	44	22	26	5,0	0,17
WAC-30	30	30	60	34	67	M10	8,6	15	49	22	29	5,0	0,22
WAC-40	40	40	76	42	87	M12	10,3	18	66	26	38	6,0	0,48
WAC-50*	50	50	92	50	103	M16	14,25	20	80	34	46	8,0	0,82

* Upon request

