



Price index



*Noise test values: max. 38 dB(A) -
Values determined at the igus® test-
lab acc. to DIN 45635 (v = 1,8 m/s)



IPA classification - Report IG0704-400: ISO
Class 1, according to standard DIN EN ISO
14644-1 for E3, Series E3.15.040.075.0 (at
v = 0.5 m/s, 1 m/s, 2 m/s)



Special equipment:
Electrically conductive
ESD/ATEX version upon request



Rapid assembly time with "zipperbars on a strip"



When to use the Series E3.22:

- If a low-noise, vibration-free version is required
- At very high speeds and/or accelerations
(Theoretically up to 100 g or 1000 m/s)
- Hard-wearing E-Chain® (more than 50 million
cycles without abrasion)
- If a very light E-Chain® is required (up to 40%
lighter than a comparable E2-E-Chain®)
- For the use of flat cables
- For small bending radii and small spaces
- If easy filling and assembly is required
- Minimal abrasion
(e.g. cleanroom applications)



When not to use it:

- If a particularly low-cost,
snap-open solution is required
- ▶ Series E/Z14 Easy Chain®, page 3.32
- If a simple, non snap-open E-Chain® is required
- ▶ Series 1400/1450/1480/1500 E2/000, page 5.92

- 1 Smooth running, due to the igus® approved
"E6-Principle", 38db(A) max.*
- 2 For high speed and high accelerations
- 3 Small pitch
- 4 3-piece Design
- 5 Modular design- opening crossbars,
interior separation and link all in one band
- 6 Easy cable access due to
fast zip-open mechanism
- 7 Extensive external bearing surfaces and high load
capacity by means of interlocking bearing surfaces
- 8 Easy shortening/lengthening
- 9 Suits flat cables
- 10 Accessories, such as interior separations, strain
relief and mounting bracket, are available



Order example complete E-Chain®

Please indicate chain-lengths or number of links Example: 1 m or 60 links

1 m E3.22.060.044.0



E-Chain®

with 2 separators E3.22.11 assembled every 2nd link

Interior separation

1 set E3.22.060.12



Mounting bracket



Unsupported length

FL_G = with straight upper run

FL_B = with permitted sag

Further information ► **Design, page 1.12**

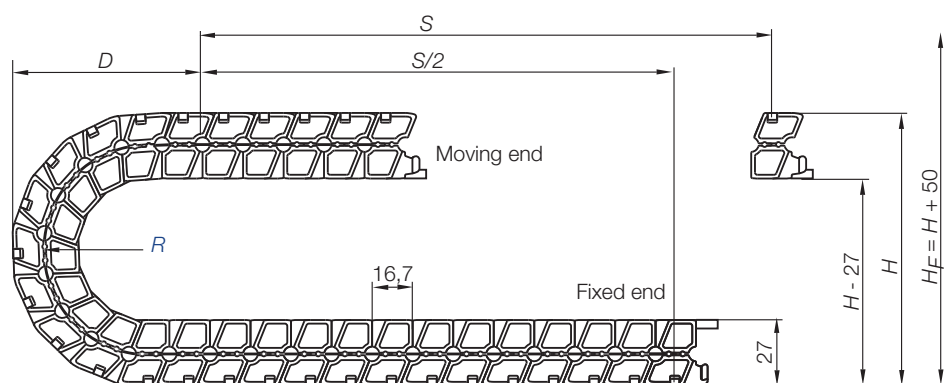
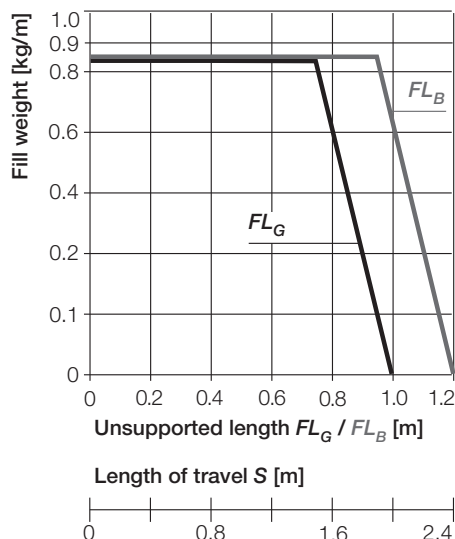
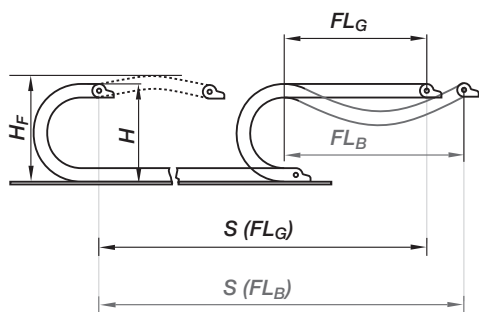

- S = Length of travel
- R = Bending radius
- H = Nominal clearance height
- H_F = Required clearance height
- D = Overlength E-Chain® radius in final position
- $K = \pi \cdot R + \text{"safety"}$



Short travels - unsupported

Unsupported E-Chains® feature positive camber over short travels. This must be accounted for when specifying the clearance height H_F . Please consult igus® if space is particularly restricted.

Pitch = 16,7 mm/link Links/m = 60 (1.002 mm) Chain length = $S/2 + K$

R	044	050	075
H	114	126	176
D	74	80	105
K	175	195	270

The required clearance height:
 $H_F = H + 50$ mm
 (with 0,3 kg/m fill weight)

Speed / acceleration FL_G	max. 20 [m/s] / max. 200 [m/s ²]
Speed / acceleration FL_B	max. 3 [m/s] / max. 6 [m/s ²]
Gliding speed / acceleration (maximum)	upon request
permitted temperature °C	-40° up to +70° C
Flammability class	VDE 0304 IIC UL94 HB

Technical Data



Details of material properties

► page 1.38



System E3
 Inner height: 22 mm

Phone +49- (0) 22 03-96 49-800
 Fax +49- (0) 22 03-96 49-222



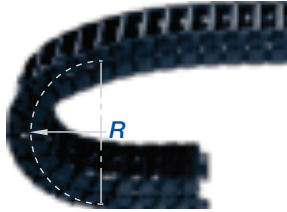
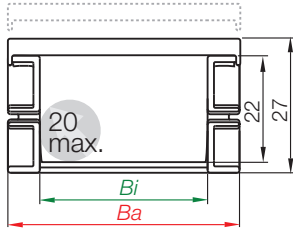

Part No. structure

E3.22.060.044.0



Series E3.22 - snap-open along outer radius

Part No.	B_i [mm]	B_a [mm]	R [mm]	Bending radii			Weight [kg/m]
E3.22.020.□.0	20	32	044	050	075	≈ 0,30	
E3.22.040.□.0	40	52	044	050	075	≈ 0,32	
E3.22.060.□.0	60	72	044	050	075	≈ 0,41	

The bending radius **050** is available upon request for Series E3.22.060

Delivery time: approx. 6-8 weeks after receipt of order!

Supplement Part No. with required radius. Example: E3.22.060.044.0

0 = standard color, other colors ► page 1.39 · Pitch = 16,7 mm/link - Links/m = 60



E3 | Series E3.22 | Accessories | Interior Separation

Vertical separator, slotted (single)

unassembled E3.22.01

assembled E3.22.11



Vertical separators

Vertical separators are used if a vertical subdivision of the E-Chain® interior is required -

- Subdivision with vertical separator E3.22.11 (slotted 3 times)

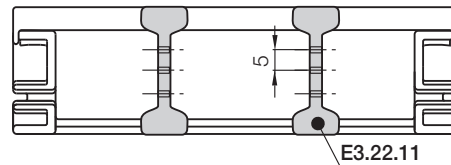



Mounting angle - Polymer

- For fastening the E-Chain® to the fixed end
- Simple fastening to base is possible
- Corrosion-resistant
- Various mounting options
- Easy to assemble

Moving end
E3.22...1

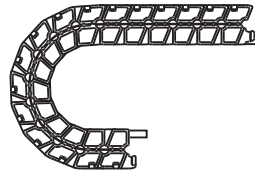

E3.22.....2
Fixed end

Example: Possible installation conditions for E3 mounting brackets

E3.22.....2
Fixed end

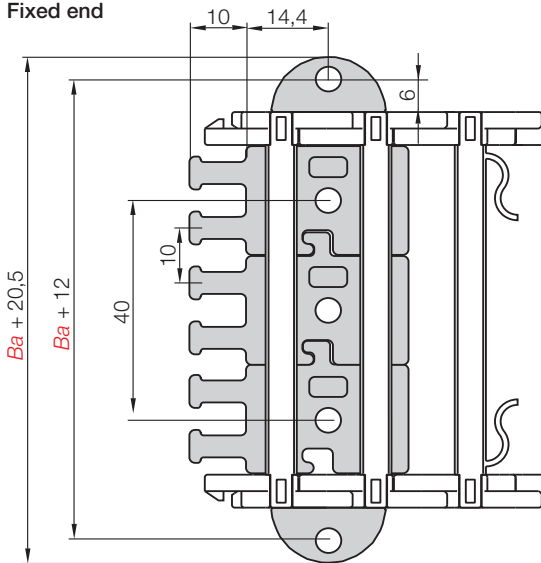

E3.22...1
Moving end

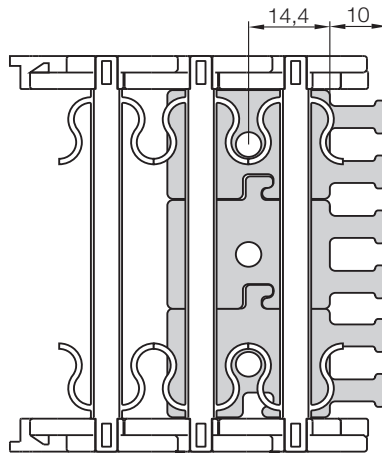

Dimensions and order configurations

Part No. structure

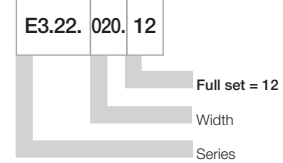

For E-Chain®	Part No. full set strain relief for both sides + 2 mounting angles	Part No. strain relief for both sides	Part No. mounting angle (single part)
E3.22.020.	E3.22.020.12	E3.020.12	E3.22.00
E3.22.040.	E3.22.040.12	E3.040.12	E3.22.00
E3.22.060.	E3.22.060.12	E3.060.12	E3.22.00

Full set, for both ends:

E3.22. 020. 12

Single-part order:

E3.22. 020. 1

Moving end mounting bracket

E3.22. 020. 2

Fixed end mounting bracket

E3.22.XXX.12



E3 with strain relief for both sides and mounting angles

E3.00.020



Strain relief for both sides as single parts

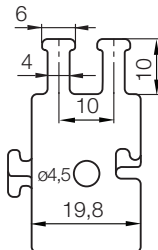

E3.22.00



Mounting angle as single part

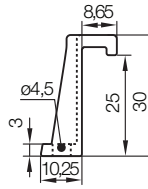

Phone +49- (0) 22 03-96 49-800
Fax +49- (0) 22 03-96 49-222

