

Price index



**ESD classification:**  
Electrically conductive ESD/ATEX version upon request



**High torsional rigidity**



**Side-mounted - unsupported**



Opening E-Chains®: Remove crossbars and clips - Insert screwdriver into the slot, push down, release by lever action



Remove lids/bottoms (E-Tubes) - Insert screwdriver into the slot, release by lever action



**When to use the Series 14040/14140/R18840:**

- For achieving simple, economical solutions
- For minimizing a chain's external width at any given internal width
- For use if Series 400 proves too large



**When not to use it:**

- If a quieter version is required
  - ▶ Series E4.56, page 7.62
- If long side-mounted, unsupported length is required
  - ▶ Series E4.56, page 7.62

- 1 Crossbars on E-Chains® are removable along both radii
- 2 Hinged snap-open removable lids along outer radius of E- Tube
- 3 Closed and open styles can be combined
- 4 Lateral glide surfaces for side-mounted operation
- 5 Wide, rounded plastic crossbars - cable friendly
- 6 Removable lids along inner radius
- 7 Locking or pivoting mounting brackets available
- 8 KMA mounting brackets with attachment points on all sides
- 9 Integrated strain relief possible
- 10 Stronger version with undercut design
- 11 E-Chains® also available with reverse bending radius "RBR"

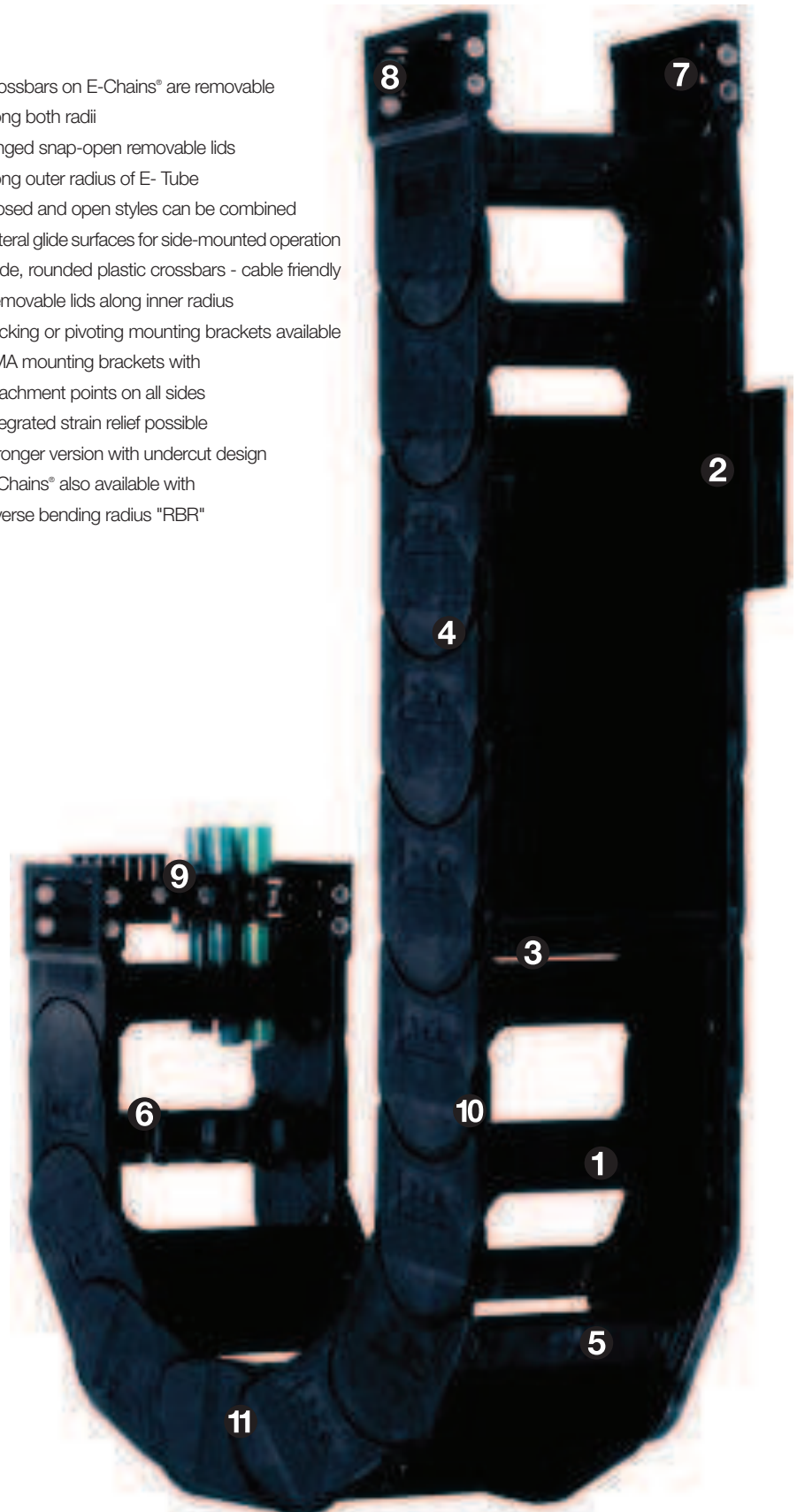

**Order example complete E-Chain®**

Please indicate chain-lengths or number of links **Example: 5 m or 55 links**

5 m **14040.30.300.0**



**E-Chain®**

with 2 separators **411** assembled every 2<sup>nd</sup> link



**Interior separation**

1 set **141400.30.12.C**



**Mounting bracket**



### Unsupported length

$FL_G$  = with straight upper run

$FL_B$  = with permitted sag

Further information ► Design, page 1.12

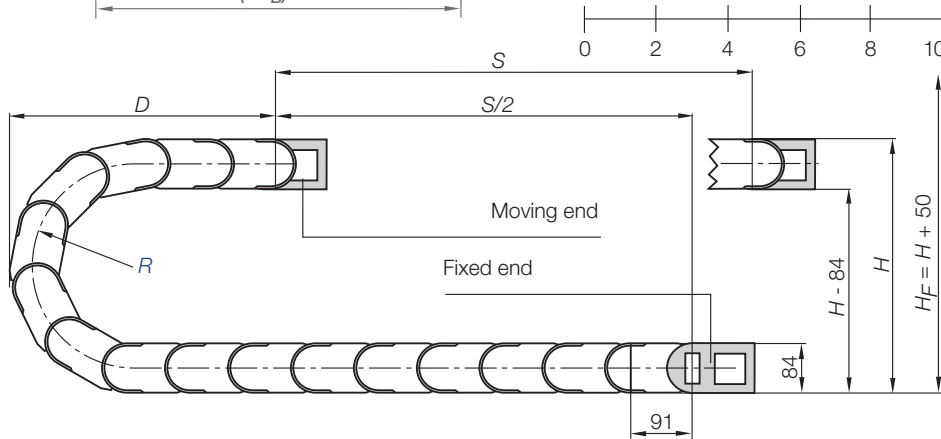
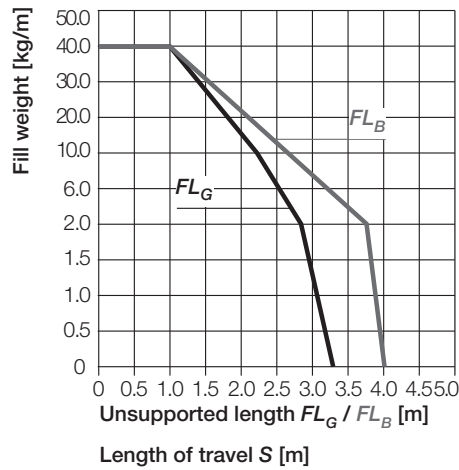
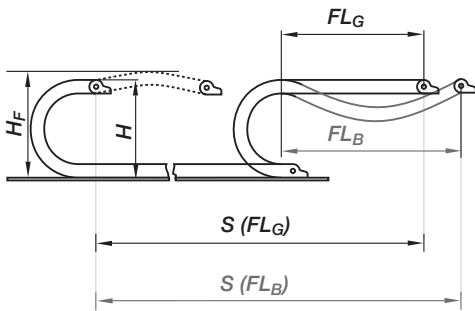

Pitch = 91 mm/link    Links/m = 11 (1001 mm)    Chain length =  $S/2 + K$

| R           | 135 | 150 | 175  | 200  | 250  | 300  | 400  | 500  |
|-------------|-----|-----|------|------|------|------|------|------|
| $H_{+25}^0$ | 360 | 385 | 435  | 485  | 585  | 685  | 885  | 1085 |
| D           | 270 | 285 | 310  | 335  | 385  | 435  | 535  | 635  |
| K           | 650 | 750 | 825  | 900  | 1050 | 1225 | 1450 | 1775 |
| $H_2$       | 266 | 266 | 266  | 266  | 266  | 266  | 266  | 266  |
| $D_2^{+25}$ | 390 | 450 | 530  | 710  | 920  | 1120 | 1530 | 1830 |
| $K_2$       | 728 | 819 | 1001 | 1274 | 1638 | 1911 | 2548 | 3185 |

- S = Length of travel
  - R = Bending radius
  - H = Nominal clearance height
  - $H_F$  = Required clearance height
  - $H_{RI}$  = Trough inner height
  - D = Overlength E-Chain® radius in final position
  - $K = \pi \cdot R + \text{"safety"}$
  - $D_2$  = Over length - long travels, gliding
  - $K_2$  = \*Further add-on
  - $H_2$  = \*Mounting height
- \*if the mounting bracket location is set lower

#### Other installation methods

- Vertical, hanging  $\leq 80$  m
- Vertical, standing  $\leq 6$  m
- Side mounted, un supp.  $\leq 2$  m
- Rotary requires further calculation
- Unsupported length of upper run = upon request

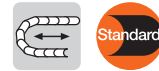

#### Short travels - unsupported

Unsupported E-Chains® feature positive camber over short travels. This must be accounted for when specifying the clearance height  $H_F$ . Please consult igus® if space is particularly restricted.

The required clearance height:

$H_F = H + 50$  mm  
(with 2,0 kg/m fill weight)

Long travel lengths from 10 m to max. 150 m    Chain length =  $S/2 + K_2$

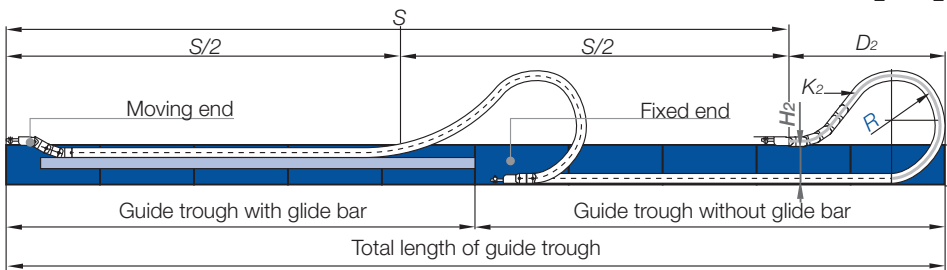

In case of travels between 4 and 10 m we recommend a longer unsupported length.



#### Gliding, long travel applications (max. 150 m)

In this case the E-Chain® upper run will be introduced in a guide trough on the lower run. We recommend to realize the engineering of such a plant by our technicians.

#### Technical Data

|  |  |
|--|--|
| Speed / acceleration $FL_G$            | max. 20 [m/s] / max. 200 [m/s <sup>2</sup> ] |
| Speed / acceleration $FL_B$            | max. 3 [m/s] / max. 6 [m/s <sup>2</sup> ]    |
| Gliding speed / acceleration (maximum) | max. 10 [m/s] / max. 50 [m/s <sup>2</sup> ]  |
| Material - permitted temperature °C    | igumid G / -40° up to +120° C                |
| Flammability class, igumid G           | VDE 0304 IIC UL94 HB                         |



Details of material properties

► page 1.38

56

System E4/light  
Inner height: 56 mm

Phone +49- (0) 22 03-96 49-800  
Fax +49- (0) 22 03-96 49-222



► page 7.123



For support of the lower run - Support Tray tool kit available ► page 9.70

igus® E-ChainSystems®

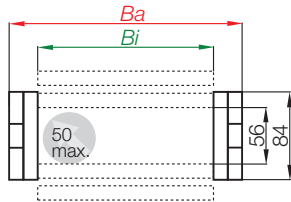

Part No. structure

14040.13.250.0



Series 14040 - E-Chain® with crossbars every link

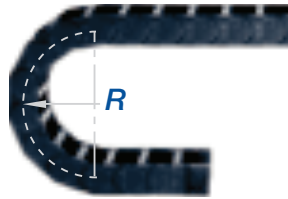

- Crossbars every link
- For rigid hydraulic hoses
- For applications particularly demanding
- Can be opened from two sides



Phone +49- (0) 22 03-96 49-800  
Fax +49- (0) 22 03-96 49-222

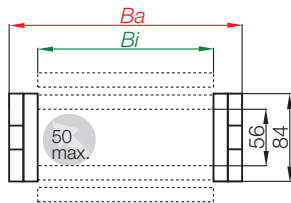

Part No. structure

14140.13.250.0



Series 14140 - E-Chain® with crossbars every 2<sup>nd</sup> link

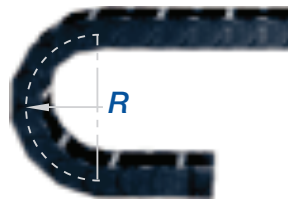

- Crossbars every 2<sup>nd</sup> link = Standard
- For nearly every situation
- Can be opened from two sides
- Easy assembly
- Stable
- Attractive price



igus® GmbH  
51147 Cologne

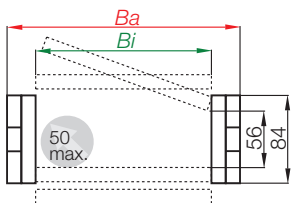

Part No. structure

18840.25.250.0



Series R18840 - Fully enclosed E-Tube

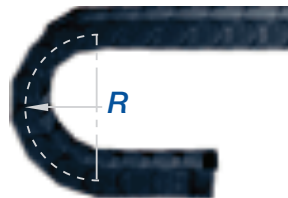

- Fully enclosed
- Excellent cable protection against dirt
- Protection against hot chips (up to 900°C)
- Lids along the entire inner radius are completely removable. Lids along the entire outer radius are single sided snap-open with a hinge on the other side to keep them attached to the chain or completely removable.



Internet: [www.igus.eu](http://www.igus.eu)  
E-mail: [info@igus.de](mailto:info@igus.de)

| Part No.              |                          | <i>Bi</i> | <i>Ba</i> | 14040  | 14140  | R18840 |
|-----------------------|--------------------------|-----------|-----------|--------|--------|--------|
|                       |                          | [mm]      | [mm]      | [kg/m] | [kg/m] | [kg/m] |
| 14040/14140.05.       | <input type="checkbox"/> | 50        | 76        | ≈ 2,66 | ≈ 2,48 | -      |
| 14040/14140.06.       | <input type="checkbox"/> | 65        | 91        | ≈ 2,47 | ≈ 2,51 | -      |
| 14040/14140/18840.07. | <input type="checkbox"/> | 75        | 101       | ≈ 2,75 | ≈ 2,25 | ≈ 3,20 |
| 14040/14140.08.       | <input type="checkbox"/> | 87        | 113       | ≈ 2,84 | ≈ 2,44 | -      |
| 14040/14140/18840.10. | <input type="checkbox"/> | 100       | 126       | ≈ 2,93 | ≈ 2,61 | ≈ 3,49 |
| 14040/14140.11.       | <input type="checkbox"/> | 112       | 139       | ≈ 3,06 | ≈ 2,67 | -      |
| 14040/14140/18840.12. | <input type="checkbox"/> | 125       | 151       | ≈ 3,12 | ≈ 2,71 | ≈ 3,85 |
| 14040/14140.13.       | <input type="checkbox"/> | 137       | 164       | ≈ 3,26 | ≈ 2,77 | -      |
| 14040/14140/18840.15. | <input type="checkbox"/> | 150       | 176       | ≈ 3,32 | ≈ 2,81 | ≈ 4,28 |
| 14040/14140.16.       | <input type="checkbox"/> | 162       | 189       | ≈ 3,43 | ≈ 2,86 | -      |
| 14040/14140/18840.17. | <input type="checkbox"/> | 175       | 201       | ≈ 3,54 | ≈ 2,92 | ≈ 4,54 |
| 14040/14140.18.       | <input type="checkbox"/> | 187       | 214       | ≈ 3,65 | ≈ 2,97 | -      |
| 14040/14140/18840.20. | <input type="checkbox"/> | 200       | 226       | ≈ 3,67 | ≈ 2,98 | ≈ 4,85 |
| 14040/14140.21.       | <input type="checkbox"/> | 212       | 239       | ≈ 3,78 | ≈ 3,04 | -      |
| 14040/14140.22.       | <input type="checkbox"/> | 225       | 251       | ≈ 3,85 | ≈ 3,07 | -      |
| 14040/14140.23.       | <input type="checkbox"/> | 237       | 264       | ≈ 3,98 | ≈ 3,14 | -      |
| 14040/14140/18840.25. | <input type="checkbox"/> | 250       | 276       | ≈ 4,07 | ≈ 3,18 | ≈ 5,58 |
| 14040/14140.26.       | <input type="checkbox"/> | 262       | 289       | ≈ 4,16 | ≈ 3,22 | -      |
| 14040/14140/18840.27. | <input type="checkbox"/> | 275       | 301       | ≈ 4,27 | ≈ 3,28 | ≈ 5,85 |
| 14040/14140.28.       | <input type="checkbox"/> | 287       | 314       | ≈ 4,29 | ≈ 3,29 | -      |
| 14040/14140/18840.30. | <input type="checkbox"/> | 300       | 326       | ≈ 4,51 | ≈ 3,40 | ≈ 6,24 |
| 14040/14140.31.       | <input type="checkbox"/> | 312       | 339       | ≈ 4,57 | ≈ 3,42 | -      |
| 14040/14140.32.       | <input type="checkbox"/> | 325       | 351       | ≈ 4,60 | ≈ 3,44 | -      |
| 14040/14140.33.       | <input type="checkbox"/> | 337       | 364       | ≈ 4,77 | ≈ 3,53 | -      |
| 14040/14140/18840.35. | <input type="checkbox"/> | 350       | 376       | ≈ 4,93 | ≈ 3,61 | ≈ 6,99 |
| 14040/14140.36.       | <input type="checkbox"/> | 362       | 389       | ≈ 4,94 | ≈ 3,61 | -      |
| 14040/14140.37.       | <input type="checkbox"/> | 375       | 401       | ≈ 4,95 | ≈ 3,62 | -      |
| 14040/14140.38.       | <input type="checkbox"/> | 387       | 414       | ≈ 5,04 | ≈ 3,66 | -      |
| 14040/14140/18840.40. | <input type="checkbox"/> | 400       | 426       | ≈ 5,24 | ≈ 3,76 | ≈ 7,94 |
| 14040/14140.41.       | <input type="checkbox"/> | 412       | 439       | ≈ 5,39 | ≈ 3,84 | -      |
| 14040/14140.42.       | <input type="checkbox"/> | 425       | 451       | ≈ 5,54 | ≈ 3,92 | -      |
| 14040/14140.43.       | <input type="checkbox"/> | 437       | 464       | ≈ 5,61 | ≈ 3,95 | -      |
| 14040/14140.45.       | <input type="checkbox"/> | 450       | 476       | ≈ 5,68 | ≈ 3,98 | -      |
| 14040/14140/18840.46. | <input type="checkbox"/> | 462       | 489       | ≈ 5,70 | ≈ 3,99 | ≈ 8,40 |
| 14040/14140.47.       | <input type="checkbox"/> | 475       | 501       | ≈ 5,83 | ≈ 4,06 | -      |
| 14040/14140.48.       | <input type="checkbox"/> | 487       | 514       | ≈ 5,86 | ≈ 4,08 | -      |
| 14040/14140.50.       | <input type="checkbox"/> | 500       | 526       | ≈ 5,96 | ≈ 4,13 | -      |
| 14040/14140.51.       | <input type="checkbox"/> | 512       | 539       | ≈ 5,98 | ≈ 4,14 | -      |
| 14040/14140.52.       | <input type="checkbox"/> | 525       | 551       | ≈ 6,03 | ≈ 4,16 | -      |
| 14040/14140.53.       | <input type="checkbox"/> | 537       | 564       | ≈ 6,18 | ≈ 4,24 | -      |
| 14040/14140.55.       | <input type="checkbox"/> | 550       | 576       | ≈ 6,67 | ≈ 4,48 | -      |
| 14040/14140.60.       | <input type="checkbox"/> | 600       | 626       | ≈ 6,98 | ≈ 4,58 | -      |

Available bending radii

R [mm]  135\*\*  150  175  200  250  300  400  500

Supplement Part No. with required radius. Example: 14040.30.  300 .0

0 = standard color, other colors ▶ page 1.39 · Pitch = 91 mm/link - Links/m = 11

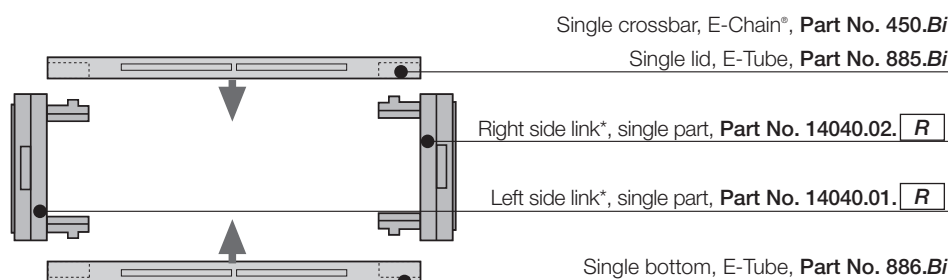

## Hot Chips up to 850°C

E-Tubes that repel hot chips, up to 850°C. Some applications, depending on amount and size of the chips, can burn or melt the surface. That is no longer the case with the igus® "igumid HT" material. Order example:

Full E-Tube made of HT:

**18840.40.150.0.HT**

Lids made of HT:

**18840.40.HTE.150.0**

\*for long travels upon request

Further Information:

[www.igus.de/en/HT](http://www.igus.de/en/HT)

**Delivery time up to 4 weeks!**



System E4/light  
Inner height: 56 mm

Phone +49- (0) 22 03-96 49-800  
Fax +49- (0) 22 03-96 49-222

\* Removable lid only,

no hinged option

\*\* not available for R18840



Extender crossbar for large diameter hoses ▶ page 7.130

## Part No. E-Chain® - links, single parts

\*View from the fixed point of the E-Chain®/E-Tube

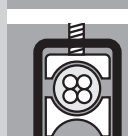

▶ page 7.123





Vertical separators are used if a vertical subdivision is required. In the standard configuration, a separator is mounted at every second link. **Note:** Observe a lateral spacing of at least 16 mm!

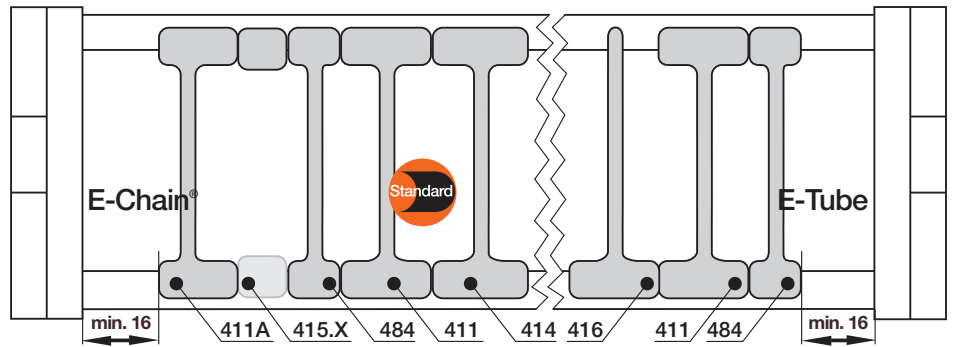

Vertical separator  
401



Vertical separator  
483



Spacer  
405.XX



Locking separator  
404



Vertical separator  
406



Asymmetric  
separator  
401A

|   |     |
|---|-----|
| Vertical separator<br>for E-Chains®/E-Tubes |     |
| unassembled                                 | 401 |
| assembled                                   | 411 |

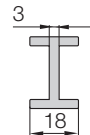

|   |     |
|---|-----|
| Vertical separator<br>for E-Chains®/E-Tubes |     |
| unassembled                                 | 483 |
| assembled                                   | 484 |

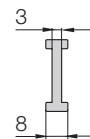

|                          |        |
|--------------------------|--------|
| Spacer*<br>for E-Chains® |        |
| unassembled              | 405.XX |
| assembled                | 415.XX |

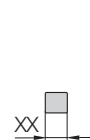

|                                    |     |
|------------------------------------|-----|
| Locking separator<br>for E-Chains® |     |
| unassembled                        | 404 |
| assembled                          | 414 |

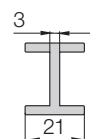

|                                   |     |
|-----------------------------------|-----|
| Vertical separator<br>for E-Tubes |     |
| unassembled                       | 406 |
| assembled                         | 416 |

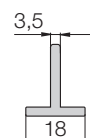

|                                       |      |
|---------------------------------------|------|
| Asymmetric separator<br>for E-Chains® |      |
| unassembled                           | 401A |
| assembled                             | 411A |

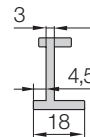

\*For side-mounted applications

### Option 1: Vertical separators and spacers

● **Standard separator 401 for E-Chains®/E-Tubes** offers safe stability due to its broad foot design, also when used with thick cables or hoses.

● **Vertical separator 483 with a narrow foot for E-Chains® and E-Tubes** with applications where a large number of small cables need to be individually separated.

● Separators (e.g. "side mounted") for E-Chains® can be fixed in their position with **Spacers 405.XX**. The available inner height will be reduced by 2 mm, per spacer and side. To avoid this, the parts can be assembled on outside of the crossbar (not for long travels) **XX = width of the spacer** (available 10, 15, 20, 30 and 40 mm)

### Additionally:

● **Locking separator for E-Chains® 404** - with increased retention force for applications exposed to very high humidity or extreme loads. The extra retention force is achieved by asymmetric claws for the crossbar. Ensure proper alignment

● **Locking separator 406 for E4-Tubes** - safe fitting locked on lid or bottom of the Tube and sideways slideable. The opposing lid or bottom can easily be opened and closed. Especially capable if many separators need to be assembled on a tight inner width.

● **Asymmetric separator 401A for E-Chains®** with an 18 mm base, for combinations between spacers of different widths and vertical separators in side-mounted applications, for instance.

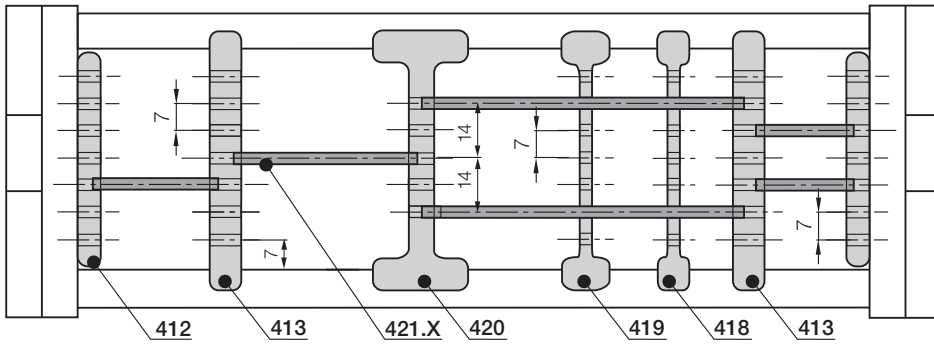

For use with many cables of differing diameters. E-Chains® and E-Tubes can be subdivided both vertically and horizontally. The shelves can be arranged elevator-shifted with different bottoms

### Option 2: Shelves

● Side plates 402, middle plates 403 and shelves 420.X form the basic pattern of a shelf system. Shelves of various widths can be arranged at 7 different heights (in 7 mm increments).

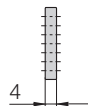

| Side plate for E-Chains®/E-Tubes |     |
|----------------------------------|-----|
| unassembled                      | 402 |
| assembled                        | 412 |

● Locking vertical separator 410, slotted combined with shelves (only for E-Chains®).

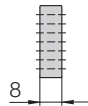

| Middle plate for E-Chains®/E-Tubes |     |
|------------------------------------|-----|
| unassembled                        | 403 |
| assembled                          | 413 |

● Slotted separators 408 are used for very fine subdivisions. However, they cannot be retrofitted into an existing separation system without dismantling the interior separators first.

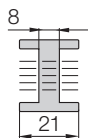

| Locking vertical separator for E-Chains® |     |
|--|-----|
| unassembled                              | 410 |
| assembled                                | 420 |

● The unilateral open slotted separator 409 can be retrofitted into an existing interior separation system without a need for dismantling the interior separators. During an installation of open slotted separators, the top and bottom notches cannot be occupied by shelves.

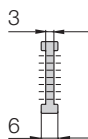

| Slotted separator for E-Chains®/E-Tubes |     |
|---|-----|
| unassembled                             | 408 |
| assembled                               | 418 |

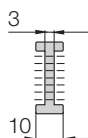

| Open slotted separator for E-Chains®/E-Tubes |     |
|--|-----|
| unassembled                                  | 409 |
| assembled                                    | 419 |

| Width X [mm] | Part No. unassembled | Part No. assembled |
|--------------|----------------------|--------------------|
| 018          | 420.18               | 421.18             |
| 023          | 420.23               | 421.23             |
| 025          | 420.25               | 421.25             |
| 028          | 420.28               | 421.28             |
| 033          | 420.33               | 421.33             |
| 043          | 420.43               | 421.43             |
| 050          | 420.50               | 421.50             |
| 062          | 420.62               | 421.62             |

| Width X [mm] | Part No. unassembled | Part No. assembled |
|--------------|----------------------|--------------------|
| 075          | 420.75               | 421.75             |
| 088          | 420.88               | 421.88             |
| 100          | 420.100              | 421.100            |
| 125          | 420.125              | 421.125            |
| 150          | 420.150              | 421.150            |
| 175          | 420.175              | 421.175            |
| 187          | 420.187              | 421.187            |
| 200          | 420.200              | 421.200            |



Side plate 402

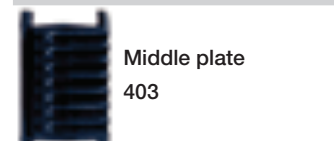

Middle plate 403

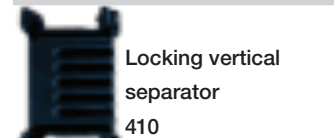

Locking vertical separator 410

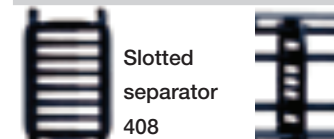

Slotted separator 408

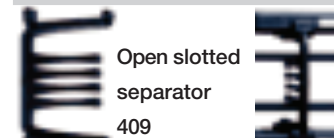

Open slotted separator 409



Shelf 420.X

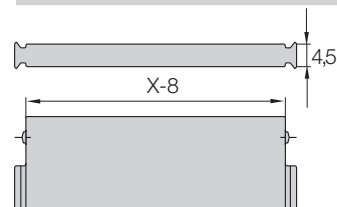

### Additional elements for interior separation

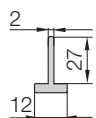

| Center crossbar |     |
|-----------------|-----|
| unassembled     | 405 |
| assembled       | 415 |

**Center crossbar** - for applications with a large number of thin cables. The center crossbar offers the option of subdividing the E-Chain® independently into upper and lower halves.

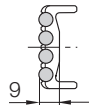

| Rollclip    |        |
|-------------|--------|
| unassembled | 489.27 |
| assembled   | 490.27 |

**Rollclip** - minimizes abrasion of particularly sensitive hoses - simply clamped onto the opening crossbar. The movable rollers compensate for relative movement between the chain and hose.

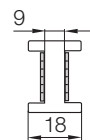

| Roller separator |     |
|------------------|-----|
| unassembled      | 429 |
| assembled        | 430 |

**Roller separator** - performs a similar function to the Rollclip, but doubles as a separator.

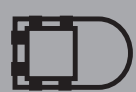



Part No. structure

14040.10 /20 /10. .0

14040.Bi1/Bi2/Bi3. .0

### Extension links - for extremely wide E-Chains® up to 3,0 m

- For applications in which particularly high fill weights necessitate extremely wide E-Chains® (up to 3000 mm)
- The extension link design allows virtually limitless side-by-side attachment of chains
- The unsupported length of a chain can be increased when additional loads are required
- Extension links can be used with E-Chains®, E-Tubes or as a combination of both
- They are suitable for unsupported and gliding applications in a guide trough
- E-Chains® with extension links are attached with KMA or steel mounting brackets

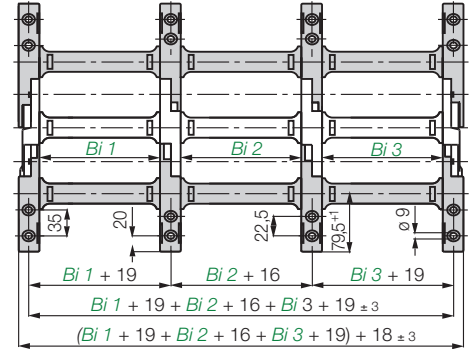

Consult igus® for your extender crossbar applications. We are happy to assist you with your design layout

### Extender crossbars - careful guide of hoses applications

- Suitable for hoses with a maximum outer diameter of 245 mm
- Gliding operation with crossbars assembled along the outer radius and a special guide trough
- Gliding operation not guaranteed with crossbars assembled along the inner radius
- The extender crossbar can either be attached to the side links directly or can be used in combination with two stranded snap-open crossbars

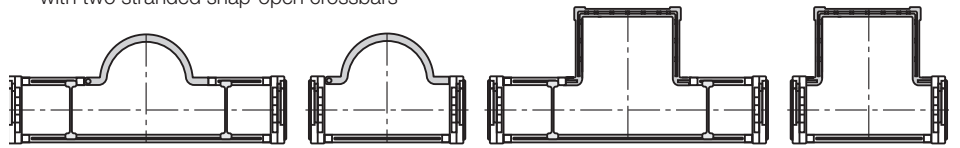

Round extender crossbar with snap-open crossbars

Attached directly to the side link

Square extender crossbar with snap-open crossbars

Attached directly to the side link

| Part No.      | Max Ø [mm] hose | Form | Installation side link | Combination with snap-open crossb. |
|---------------|-----------------|------|------------------------|------------------------------------|
| 450.15.RHD115 | 115             | ○    | -                      | +                                  |
| 450.17.RD115  | 115             | ○    | +                      | -                                  |
| 450.25.D150   | 150             | □    | +                      | -                                  |
| 450.30.D200   | 180             | □    | +                      | -                                  |
| 450.35.D250   | 195             | □    | +                      | -                                  |
| 450.40.D300   | 245             | □    | +                      | -                                  |
| 450.20.HD150  | 150             | □    | -                      | +                                  |
| 450.25.HD200  | 180             | □    | -                      | +                                  |
| 450.30.HD250  | 195             | □    | -                      | +                                  |

○ = round □ = square + = yes / - = no



### E4 clip-on cable binder

- For side-mounted applications ● Serves as a clip-on, lateral guide for hoses and cables on E-Chains®
- The loops can be adjusted as required ● Compatible with many E4 E-Chains® ● Stylish and economical
- One clip and one locking band are needed for each chain link ● Call us if you have any questions on project planning

| Part No.    | Form   |
|-------------|--|
| 450.B12     | Locking clip, comprising a locking element                             |
| 450.B12.200 | Locking band, comprising a locking element and band; 12 x 1,5 x 200 mm |

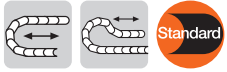

### The Standard - Option KMA\* - pivoting

- Recommended for unsupported and gliding applications
- Confined installation conditions
- Option - integrated C-profile strain relief device with Chainfix clip or strain relief tiwrap plates
- Corrosion resistant
- Universal mountable with attachment capability on all sides

\*KMA = Polymer Metal Mounting Bracket

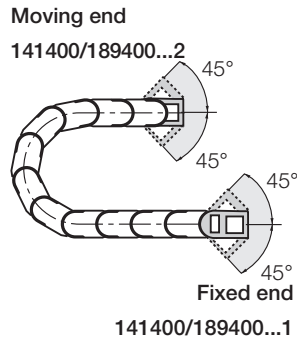

The attachment variants arising automatically by the choice of the KMA mounting bracket

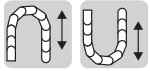
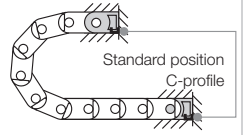

### Option KMA - locking

- Recommended for vertical hanging / standing applications

#### Additionally:

- Universal mountable
- C-profile option
- Corrosion resistant
- Locked connections
- At very high acceleration

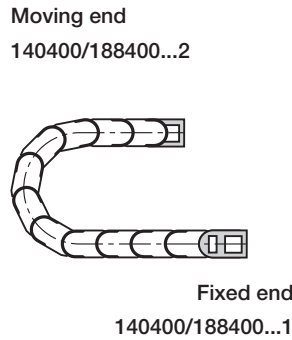

The attachment variants arising automatically by the choice of the KMA mounting bracket

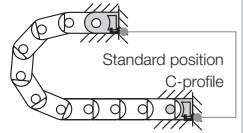

Moving end 141400/189400...2 (pivoting)  
140400/188400...2 (locking)

Fixed end (pivoting) 141400/189400...1  
(locking) 140400/188400...1

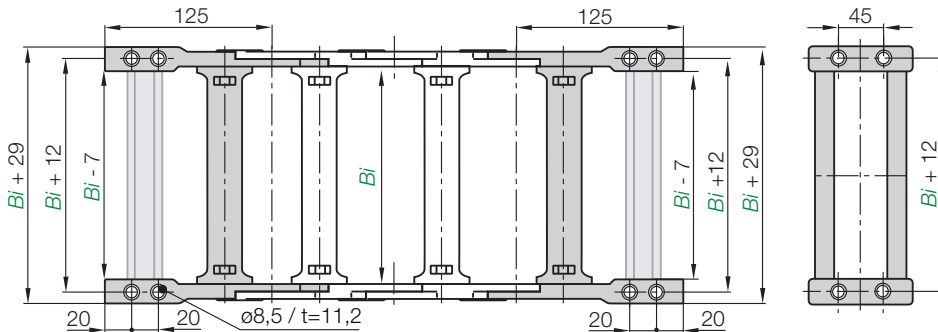

### Dimensions and order configurations

#### Part No. structure (pivoting)

|                    |     |     |                         |
|--------------------|-----|-----|-------------------------|
| 141400.<br>189400. | 07. | 12. | C                       |
|                    |     |     | Optional with C-profile |
|                    |     |     | Full set                |
|                    |     |     | Width                   |
|                    |     |     | 141400 = E-Chain*       |
|                    |     |     | 188400 = E-Tube         |

#### Part No. structure (locking)

|                    |     |     |                         |
|--------------------|-----|-----|-------------------------|
| 140400.<br>188400. | 07. | 12. | C                       |
|                    |     |     | Optional with C-profile |
|                    |     |     | Full set                |
|                    |     |     | Width                   |
|                    |     |     | 140400 = E-Chain*       |
|                    |     |     | 188400 = E-Tube         |

| Width index | Part No. full set pivoting | Part No. full set locking | C-profile option [mm] | Width index | Part No. full set pivoting | Part No. full set locking | C-profile option [mm] |
|-------------|----------------------------|---------------------------|-----------------------|-------------|----------------------------|---------------------------|-----------------------|
| .05.        | ▶ 141400                   | 140400                    | .05.12. C 50          | .31.        | ▶ 141400                   | 140400                    | .31.12. C 312         |
| .06.        | ▶ 141400                   | 140400                    | .06.12. C 65          | .32.        | ▶ 141400                   | 140400                    | .32.12. C 325         |
| .07.        | ▶ 141400/189400            | 140400/188400             | .07.12. C 75          | .33.        | ▶ 141400                   | 140400                    | .33.12. C 337         |
| .08.        | ▶ 141400                   | 140400                    | .08.12. C 87          | .35.        | ▶ 141400/189400            | 140400/188400             | .35.12. C 350         |
| .10.        | ▶ 141400/189400            | 140400/188400             | .10.12. C 100         | .36.        | ▶ 141400                   | 140400                    | .36.12. C 362         |
| .11.        | ▶ 141400                   | 140400                    | .11.12. C 112         | .37.        | ▶ 141400                   | 140400                    | .37.12. C 375         |
| .12.        | ▶ 141400/189400            | 140400/188400             | .12.12. C 125         | .38.        | ▶ 141400                   | 140400                    | .38.12. C 387         |
| .13.        | ▶ 141400                   | 140400                    | .13.12. C 137         | .40.        | ▶ 141400/189400            | 140400/188400             | .40.12. C 400         |
| .15.        | ▶ 141400/189400            | 140400/188400             | .15.12. C 150         | .41.        | ▶ 141400                   | 140400                    | .41.12. C 412         |
| .16.        | ▶ 141400                   | 140400                    | .16.12. C 162         | .42.        | ▶ 141400                   | 140400                    | .42.12. C 425         |
| .17.        | ▶ 141400/189400            | 140400/188400             | .17.12. C 175         | .43.        | ▶ 141400                   | 140400                    | .43.12. C 437         |
| .18.        | ▶ 141400                   | 140400                    | .18.12. C 187         | .45.        | ▶ 141400                   | 140400                    | .45.12. C 450         |
| .20.        | ▶ 141400/189400            | 140400/188400             | .20.12. C 200         | .46.        | ▶ 141400/189400            | 140400/188400             | .46.12. C 462         |
| .21.        | ▶ 141400                   | 140400                    | .21.12. C 212         | .47.        | ▶ 141400                   | 140400                    | .47.12. C 475         |
| .22.        | ▶ 141400                   | 140400                    | .22.12. C 225         | .48.        | ▶ 141400                   | 140400                    | .48.12. C 487         |
| .23.        | ▶ 141400                   | 140400                    | .23.12. C 237         | .50.        | ▶ 141400                   | 140400                    | .50.12. C 500         |
| .25.        | ▶ 141400/189400            | 140400/188400             | .25.12. C 250         | .51.        | ▶ 141400                   | 140400                    | .51.12. C 512         |
| .26.        | ▶ 141400                   | 140400                    | .26.12. C 262         | .52.        | ▶ 141400                   | 140400                    | .52.12. C 525         |
| .27.        | ▶ 141400/189400            | 140400/188400             | .27.12. C 275         | .53.        | ▶ 141400                   | 140400                    | .53.12. C 537         |
| .28.        | ▶ 141400                   | 140400                    | .28.12. C 287         | .55.        | ▶ 141400                   | 140400                    | .55.12. C 550         |
| .30.        | ▶ 141400/189400            | 140400/188400             | .30.12. C 300         | .60.        | ▶ 141400                   | 140400                    | .60.12. C 600         |

Full set, for both ends:

141400. 05. 12

Single-part order:

141400. 05. 2

Mounting bracket moving end

141400. 05. 1

Mounting bracket fixed end

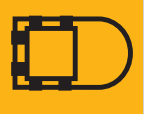



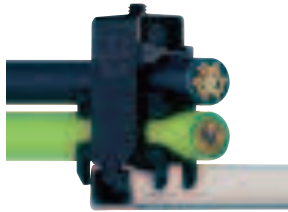

igus® Chainfix steel clamps and Chainfix stainless-steel clamps - max. pull forces, adjustable with hexagon socket. Available as single, double or triple clamps. Details ► chapter 10

### Chainfix clamps for the C-profile

| Part No. single clamps |                 | Part No. double clamps |                 | Part No. triple clamps |                 | Cable<br>ø [mm] |
|------------------------|-----------------|------------------------|-----------------|------------------------|-----------------|-----------------|
| steel                  | stainless steel | steel                  | stainless steel | steel                  | stainless steel |                 |
| CFX12.1                | CFX12.1.E       | CFX12.2                | CFX12.2.E       | CFX12.3                | -               | 06 - 12         |
| CFX14.1                | CFX14.1.E       | CFX14.2                | CFX14.2.E       | CFX14.3                | -               | 12 - 14         |
| CFX16.1                | CFX16.1.E       | CFX16.2                | CFX16.2.E       | CFX16.3                | -               | 14 - 16         |
| CFX18.1                | CFX18.1.E       | CFX18.2                | CFX18.2.E       | CFX18.3                | -               | 16 - 18         |
| CFX20.1                | CFX20.1.E       | CFX20.2                | CFX20.2.E       | CFX20.3                | -               | 18 - 20         |
| CFX22.1                | CFX22.1.E       | CFX22.2                | CFX22.2.E       | CFX22.3                | -               | 20 - 22         |
| CFX26.1                | CFX26.1.E       | CFX26.2                | CFX26.2.E       | -                      | -               | 22 - 26         |
| CFX30.1                | CFX30.1.E       | CFX30.2                | CFX30.2.E       | -                      | -               | 26 - 30         |
| CFX34.1                | CFX34.1.E       | CFX34.2                | CFX34.2.E       | -                      | -               | 30 - 34         |
| CFX38.1                | CFX38.1.E       | -                      | -               | -                      | -               | 34 - 38         |
| CFX42.1                | CFX42.1.E       | -                      | -               | -                      | -               | 38 - 42         |

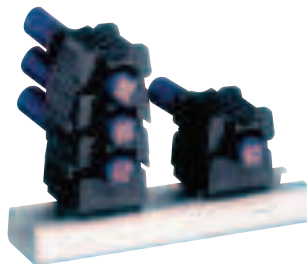

### Chainfix Clip - Modular snap-on strain relief device for C-profile

Available for all igus® E-ChainSystems® with C-profiles and also suitable for assembly in the KMA mounting brackets and clip-on strain relief for crossbars. High pull forces, plug-in modular snap-on strain relief device. Details ► chapter 10

| Cable<br>ø [mm] | Part No.<br>clamp | Part No.<br>bottom part |
|-----------------|-------------------|-------------------------|
| 04 - 08         | CFC-08-M          | CFC-08-C                |
| 08 - 12         | CFC-12-M          | CFC-12-C                |
| 12 - 16         | CFC-16-M          | CFC-16-C                |
| 16 - 20         | CFC-20-M          | CFC-20-C                |
| 20 - 24         | CFC-24-M          | CFC-24-C                |



### Chainfix Nugget for the C-Profile

Strain relief for the fixation of cables up to a diameter of Ø 30 mm. Easy to assemble, without any screws and tools. Easy strain relief due to fixation with pre-harnessed cable strap, very small space requirement. Details ► chapter 10

| Part No.   | ø max.<br>conduit [mm] | Width<br>[mm] |
|------------|------------------------|---------------|
| CFN.20     | 20                     | 10,8          |
| CFN.30.52  | 30                     | 16,8          |
| CFN.20.N35 | 20                     | 20,0          |

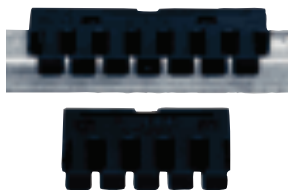

### Chainfix tiwrap plates with clip-on connection for the C-profile

Can be plugged into the KMA C-profile. Easy to assemble without any screws. Easily solvable with screwdriver nevertheless safe stop. For all E-Chains® with KMA and integrated C-profile. Details ► chapter 10

| Part No. | Width of<br>strain relief [mm] | Number<br>of teeth |
|----------|--------------------------------|--------------------|
| 3050.ZC  | 50                             | 5                  |
| 3075.ZC  | 75                             | 7                  |



### Tiewrap plate as individual part

As individual component screwed on KMA. Can be plugged in the mounting brackets. Details ► chapter 10

| Tiewrap<br>plate | No. of<br>teeth n | Dim. C<br>[mm] | Dim. B<br>[mm] | Center<br>bore |
|------------------|-------------------|----------------|----------------|----------------|
| 3050.ZB          | 5                 | 50             | 30             | -              |
| 3075.ZB          | 7                 | 75             | 55             | -              |
| 3100.ZB          | 10                | 100            | 80             | -              |
| 3115.ZB          | 11                | 115            | 95             | -              |
| 3125.ZB          | 12                | 125            | 105            | -              |
| 3150.ZB          | 15                | 150            | 130            | -              |
| 3175.ZB          | 17                | 175            | 155            | -              |
| 3200.ZB          | 20                | 200            | 180            | +              |
| 3225.ZB          | 22                | 225            | 205            | +              |
| 3250.ZB          | 25                | 250            | 230            | +              |

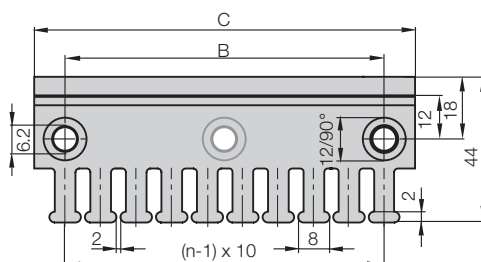
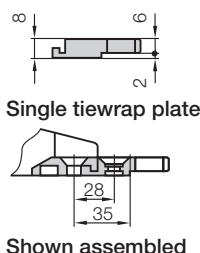

(- = no / + = yes)

# Aluminum "SuperTrough" | Basic Version



14040  
14140  
R18840

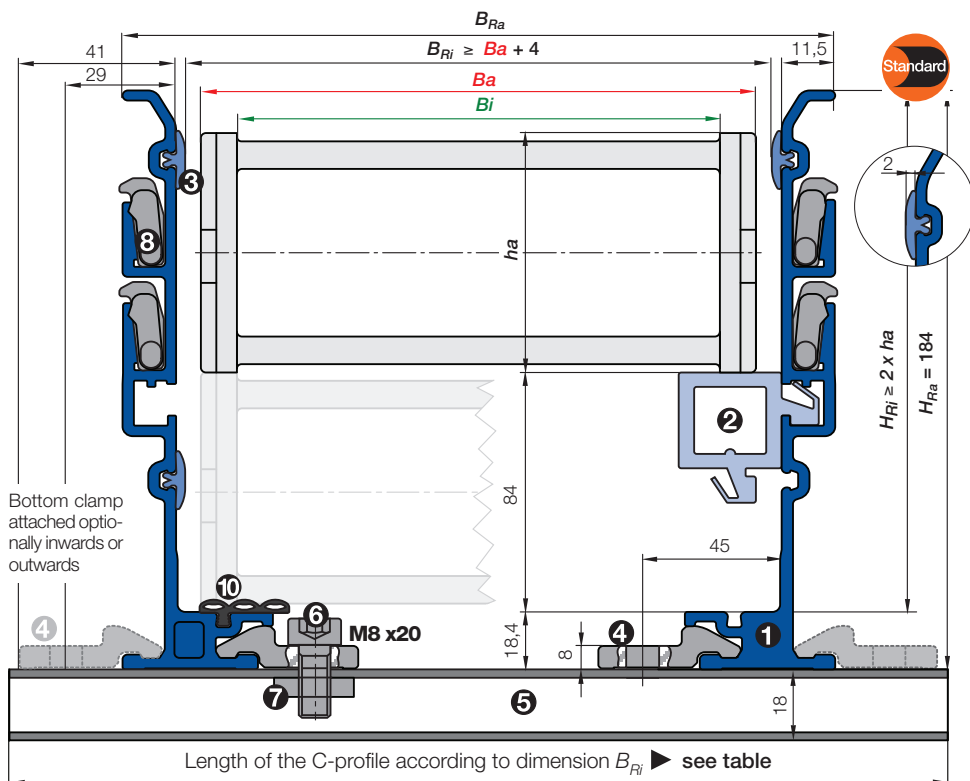

- $B_a$  = Outer width E-Chains® / E-Tube
- $B_i$  = Inner width E-Chains® / E-Tube
- $h_a$  = Outer height E-Chains® / E-Tube
- $H_{Ri}$  = Inner trough height
- $H_{Ra}$  = Outer trough height
- $B_{Ri}$  = Inner trough width ▶ depends on dim.  $B_a$
- $B_{Ra}$  = Outer trough width
- $n_{Mon}$  = Number of installation sets (left/right)
- $n_{Ri}$  = Number of troughs sets (left/right)
- !  $H_{Ri} \geq 2 \cdot h_a$
- !  $B_{Ri} \geq B_a + 4$
- = Guide trough set      ● = Glide bar
- = Installation set "Basic"      ● = C-profile

## Installation set "Basic" with C-profile

Bottom Clamp attached optionally inwards or outwards

14040.05.200.0 ▶ Order example

|     | Part No.         |                   |
|-----|------------------|-------------------|
|     | attached inwards | attached outwards |
| .05 | 80               | 960.50.200        |
| .06 | 95               | 960.50.225        |
| .07 | 105              | 960.50.225        |
| .08 | 117              | 960.50.175        |
| .10 | 130              | 960.50.200        |
| .11 | 143              | 960.50.200        |
| .12 | 155              | 960.50.225        |
| .13 | 168              | 960.50.225        |
| .15 | 180              | 960.50.250        |
| .16 | 193              | 960.50.250        |
| .17 | 205              | 960.50.275        |
| .18 | 218              | 960.50.275        |
| .20 | 230              | 960.50.300        |
| .21 | 243              | 960.50.300        |
| .22 | 255              | 960.50.325        |
| .23 | 268              | 960.50.325        |
| .25 | 280              | 960.50.350        |
| .26 | 293              | 960.50.350        |
| .27 | 305              | 960.50.375        |
| .28 | 318              | 960.50.375        |
| .30 | 330              | 960.50.400        |
| .31 | 343              | 960.50.400        |
| .32 | 355              | 960.50.425        |
| .33 | 368              | 960.50.425        |
| .35 | 380              | 960.50.450        |
| .36 | 393              | 960.50.450        |
| .37 | 405              | 960.50.475        |
| .38 | 418              | 960.50.475        |
| .40 | 430              | 960.50.500        |
| .41 | 443              | 960.50.500        |
| .42 | 455              | 960.50.525        |
| .43 | 468              | 960.50.525        |
| .45 | 480              | 960.50.550        |
| .46 | 493              | 960.50.550        |
| .47 | 505              | 960.50.575        |
| .48 | 518              | 960.50.575        |
| .50 | 530              | 960.50.600        |
| .51 | 543              | 960.50.600        |
| .52 | 555              | 960.50.625        |
| .53 | 568              | 960.50.625        |
| .55 | 580              | 960.50.650        |
| .60 | 630              | 960.50.700        |



- **Components, trough "Basic":** ① Trough side parts, aluminum, 2 m ② Glide bar, plastic, 2 m ③ Glide strips, plastic, 2 m (without glide strips on request) ⑩ Optional: Silencer profile, rubber
- **Components, installation set "Basic":** ④ Bottom clamp, aluminum ⑤ C-profile, steel galvanized ⑥ Screw M8 x20 ⑦ Sliding nut M8 ⑧ Interface connector, plastic

## Order example: Length of travel 30 m - Center mounted for Series 14040.10.200.0 with $B_{Ri} = 130$

|  |  |          |            |
|--|--|----------|------------|
| Guide trough set (set of 2 trough side parts, incl. glide strips) <b>without</b> glide bar     | Order text: 16 m guide trough without glide bar (8 x 2 m sections) | Part No. | 974.30.SL  |
| Guide trough set (set of 2 trough side parts, incl. glide strips) <b>with</b> glide bar        | Order text: 16 m guide trough with glide bar (8 x 2 m sections)    | Part No. | 974.31.SL  |
| Installation set "Basic" complete (guide trough-sets + 1)                                      | Order text: 17 installation sets "Basic"                           | Part No. | 960.50.200 |
| Module for the fixed end   | Order text: 1 set  | Part No. | 974.81     |
| Option: For an additional noise dampening with silencer profile, please add Index A - Example: |  | Part No. | 974.30.SLA |

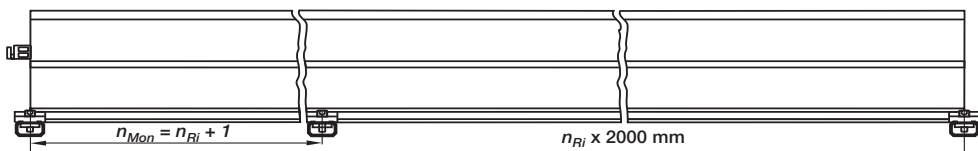

Principle sketch: Number of installation sets to be installed = Number of trough sections + 1

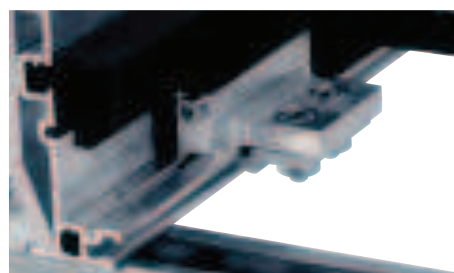

## A quick fix for mounting the stationary end of an E-Chain®

With this module for the fixed end, fast and easy mounting onto the Aluminum "SuperTrough" is now possible without any drilling. Fast mounting of the E-Chain® by clamping onto the aluminum trough

- Quick relocation of the stationary end
- No drilling necessary ▶ page 9.16

Insert for the installation set "Heavy-Duty": **974.50.XXX** instead of (960.50.XXX) on the right column "attached outwards"

Phone +49- (0) 22 03-96 49-800  
Fax +49- (0) 22 03-96 49-222



▶ Chapter 10



▶ Chapter 9



▶ page 7.123