

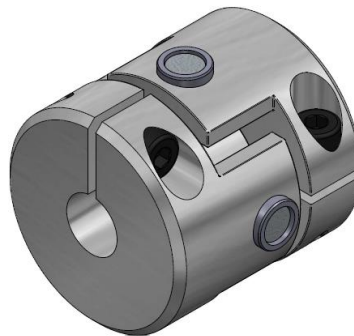

Coupling series KBGK-T

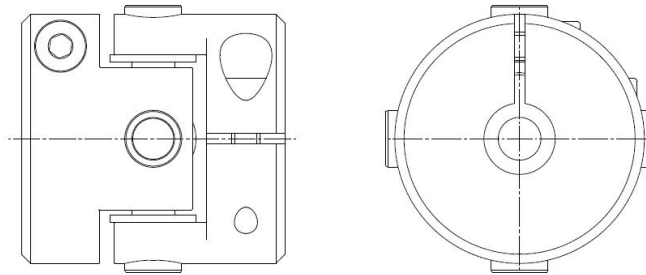

RoHS

General Information

The installation and operation instructions are an essential factor of the KBK cardan couplings. It indicates tips for proper assembly, operation and maintenance. Please read these instructions carefully and follow the directions. Non-observance may result in failure of the KBK cardan coupling.

Safety Instructions

 <p>ATTENTION!</p>	<ul style="list-style-type: none">- Installation may be performed by trained and specialized staff only.- Rotating couplings are hazard areas. The user/operator has to ensure appropriate protective measures. Do not reach into the operation area of the coupling if it is still in operation. Secure the machine against unintentional power-up during assembly work.
--	--

Manufacturer's Declaration

In accordance with directive 2006/42/EC annex IIB, shaft couplings are no machines as per the machinery directive, but components for installations in machines. Operation is not permitted, unless the directives according to the machinery directives are complied with upon integration in the final product.





Cardan coupling with clamping hubs: KBGK-T



Function



The KBGK-T are based on the principle of a cardan joint. The hubs are not fixed on the cross joint, but slide in bearings above it. They compensate high radial and angular misalignment and have also extremely low restoring forces. Because of the use of special bushes and guides, they are durable, very stiff and almost free of backlash.

Shaft-hub connections

KBK cardan couplings may only be used in accordance with the technical data mentioned in the catalogue. Any subsequent processing is not permitted.

Preparation for assembly

Avoid using any force. The shafts and bores of the hubs to be connected must be free from dirt and burrs. Please check the connection dimensions of the shafts (as well as the dimensions regarding the key) and check the tolerances. KBK cardan couplings have got an H7 fit. This fitting tolerance and the shaft extension facilitate both assembly and disassembly. The recommended fitting tolerance is 0,02mm - 0,05mm.

 ATTENTION!	Any oils and fats including molybdenum disulfide or any other high-pressure additives as well as lubricating pastes may not be used.
 Information!	To ensure the maximum offset compensation of the coupling, observe the max. Interference circle diameter of the respective size. Please refer to the catalogue data sheet.





Assembly

Slide the complete cardan coupling onto the shaft. In the correct axial position, tighten the clamping screws (F) to the tightening torque stated in the table by using a torque wrench. Insert the second shaft (i.e. shaft encoder) and tighten the clamping screw (F) in the correct axial position as mentioned above.

KBGK-T/	18	27	35	56	75	100
T _A (Nm) (F)	0,54	1,9	4,6	15,7	38	130

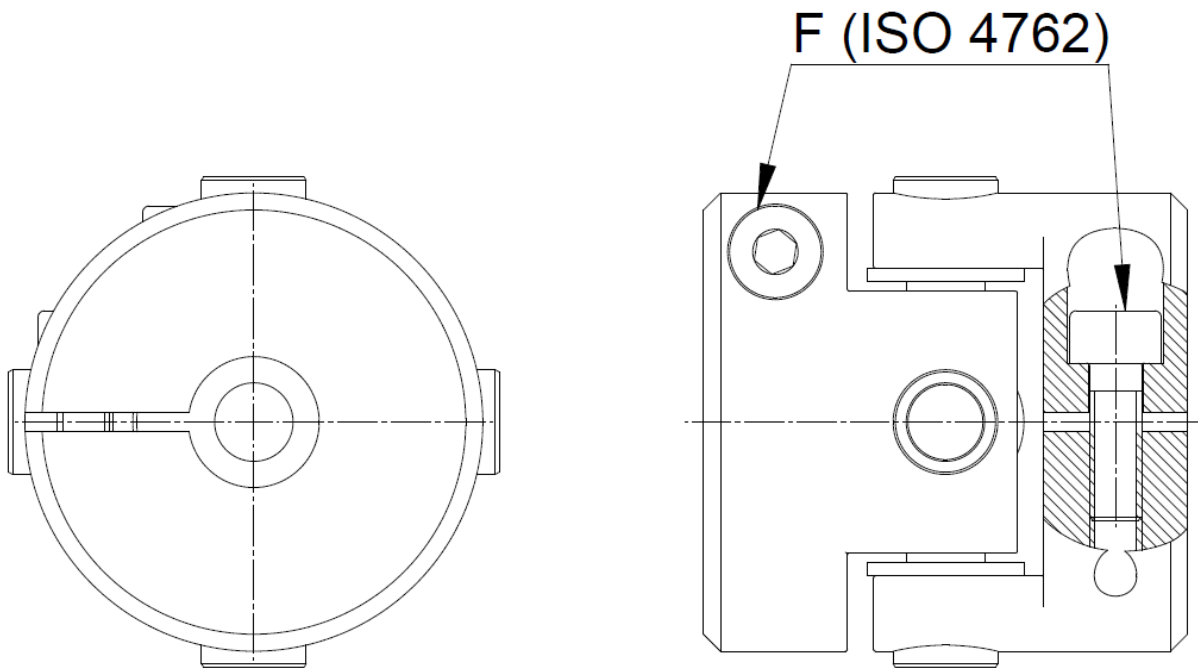

Disassembly



In order to disassemble the KBK cardan coupling, loosen the clamping screws (F).

Maximum misalignment

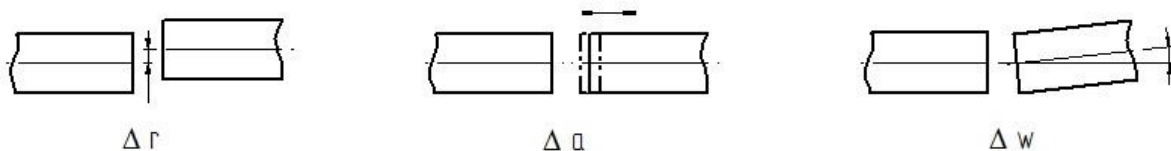
KBK cardan couplings compensate lateral and angular shaft misalignment.





 Information!	The maximum guideline value for the different misalignments can be found in our catalogue under 'technical information'. They provide security to compensate operation-related external influences e.g. thermal expansions and / or sinking foundation.
 ATTENTION!	An exact alignment of the KBK cardan coupling increases the service life and the smooth running of the entire drive train is positively influenced.

Maintenance

KBK cardan couplings are maintenance-free. Regular inspection intervals should include a visual check of the KBK cardan couplings.

Transportation

KBK cardan couplings are delivered ready for installation. Upon incoming goods inspection the cardan couplings should be stored in their original packaging and in this way they should be made available for installation. Operating and installation instructions should be always accessible for everybody at the installation location upon installation.

