

Spannsatz

optional komplett
in Edelstahl

inklusive
Nickel-Zink-
Beschichtung

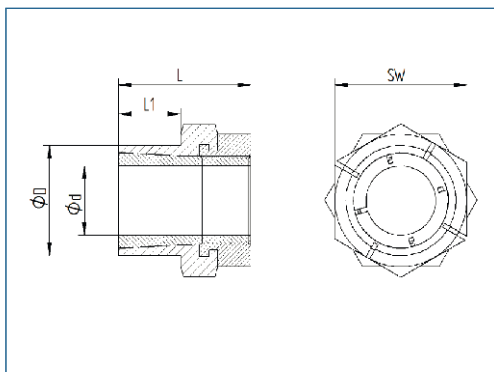

übertragbares Drehmoment	mittel
Flächenpressung auf der Nabe	mittel
selbstzentrierend	ja
Axialverschiebung der Nabe während der Montage	ja
Bauhöhe D/d	mittel
Baulänge	mittel

Bestellbeispiel

KBS 59 - 10 x 18

Typ Ød ØD

Die empfohlenen Bearbeitungstoleranzen für die Druckflächen sind: Welle h8 / Nabe H8

Innen / Außen Ø d x D	Drehmoment T Nm	Abmessungen			Flächenpressung an		TA	Axialkraft F _{AX} (kN)	Gewicht g
		L mm	L 1 mm	SW mm	Welle Pw N/mm ²	Nabe Pn N/mm ²			
5 x 12	10	19	9	14	264	119	10	4.0	16.0
6 x 12	12	19	9	14	220	119	10	4.0	15.0
7 x 14	20	22	11	16	205	121	17	5.8	23.0
8 x 14	23	22	11	16	180	121	17	5.8	21.0
9 x 18	43	24	12	22	246	144	35	9.7	47.0
10 x 18	48	24	12	22	221	144	35	9.7	44.0
11 x 20	59	24	12	22	225	145	44	10.8	47.0
12 x 20	65	24	12	22	207	145	44	10.8	44.0
14 x 24	93	28	15	27	179	118	65	13.3	76.0
15 x 24	99	28	15	27	167	118	65	13.3	72.0
16 x 24	106	28	15	27	156	118	65	13.3	67.0
17 x 26	163	34	16	32	187	148	110	19.2	122.0
18 x 30	223	36	17	36	224	155	160	24.8	176.0
19 x 30	235	36	17	36	213	155	160	24.8	169.0
20 x 30	248	36	17	36	202	155	160	24.8	162.0
22 x 38	349	41	20	46	197	134	250	31.7	338.0
24 x 38	381	41	20	46	181	134	250	31.7	315.0
25 x 38	397	41	20	46	174	134	250	31.7	304.0
28 x 42	565	44	23	50	174	134	355	40.3	370.0
30 x 42	605	44	23	50	163	134	355	40.3	345.0
32 x 50	764	51	28	55	166	112	490	47.7	552.0
35 x 50	836	51	28	55	152	112	490	47.7	495.0
38 x 58	1140	58	32	65	155	116	700	60.2	851.0
40 x 58	1200	58	32	65	147	116	700	60.2	801.0
42 x 60	1250	63	37	65	120	94	740	59.6	841.0
45 x 60	1340	63	37	65	112	94	740	59.6	741.0