

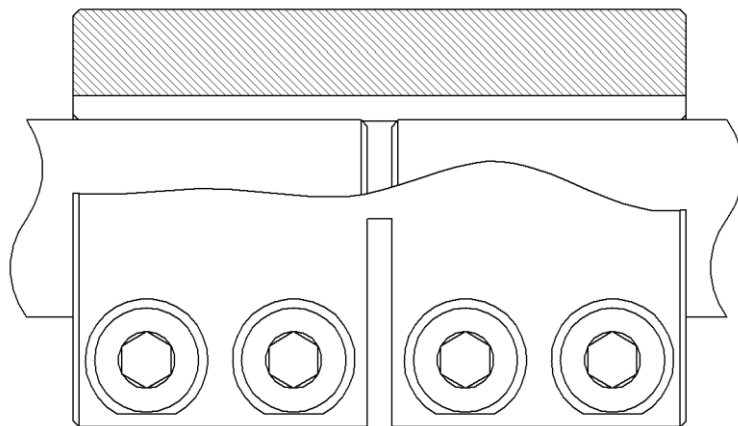

## Rigid Shaft Coupling KBST-VA

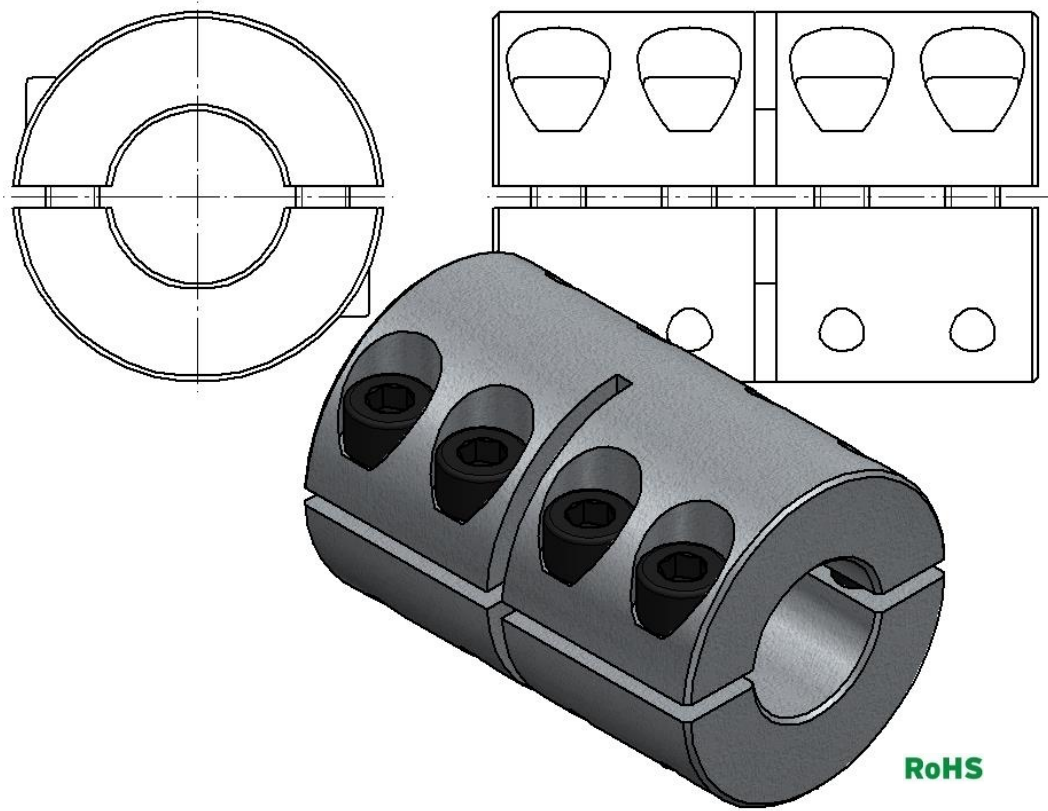

The **rigid shaft coupling KBST-VA** is a frictionally engaged, detachable shaft-shaft connection for cylindrical shafts with and without keyway.





### Characteristics

- generally delivered fully assembled
- true-running accuracy **0,02 – 0,04 mm**

### Tolerances, Surfaces

- On accurate rotating process is sufficient: **Rz ≤ 16 µm**
- KBK rigid shaft couplings do have a H7 fitting. The recommended fitting tolerance is **0,02mm - 0,05mm.**

### Components of the rigid shaft coupling KBST-VA

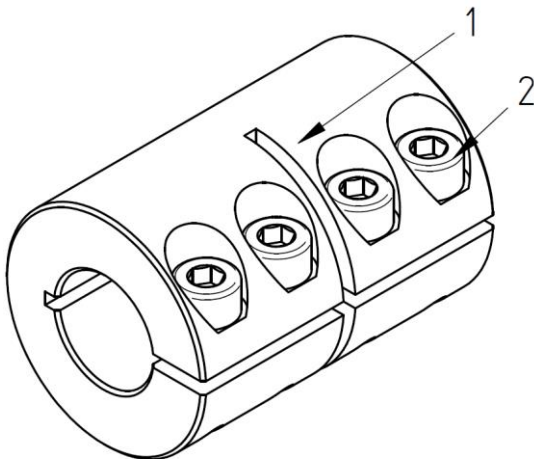

Image 2) KBST

Component	Quantity	Description
1	1	Rigid shaft coupling
2	4	Head screw with hexagon socket ISO 4762



#### Information!

Contaminated or used shaft couplings have to be disassembled and cleaned prior to installation. Then apply a thin layer of a low-viscosity oil (e.g. Castrol 4 in 1 or Klüber Quietsch Ex).



## Assembly of the coupling

- Check the shaft-position regarding the permitted tolerance (fitting tolerance: 0,02mm - 0,05mm).
- Clean and degrease the contact surfaces of the shafts to be connected. Then apply a thin layer of low-viscosity oil (e.g. Castrol 4 in 1 or Klüber Quietsch Ex).



### **Attention!**

Do not use any oil or grease including molybdenum disulphide or extreme pressure additives as well as sliding grease-pastes.

- Loosen the clamping screws (but do not remove them) and slide the rigid shaft coupling KBST-VA onto the shaft ends to be connected.
- Slightly tighten the clamping screws manually and align both the rigid shaft coupling and the shafts (see image 3).
- 

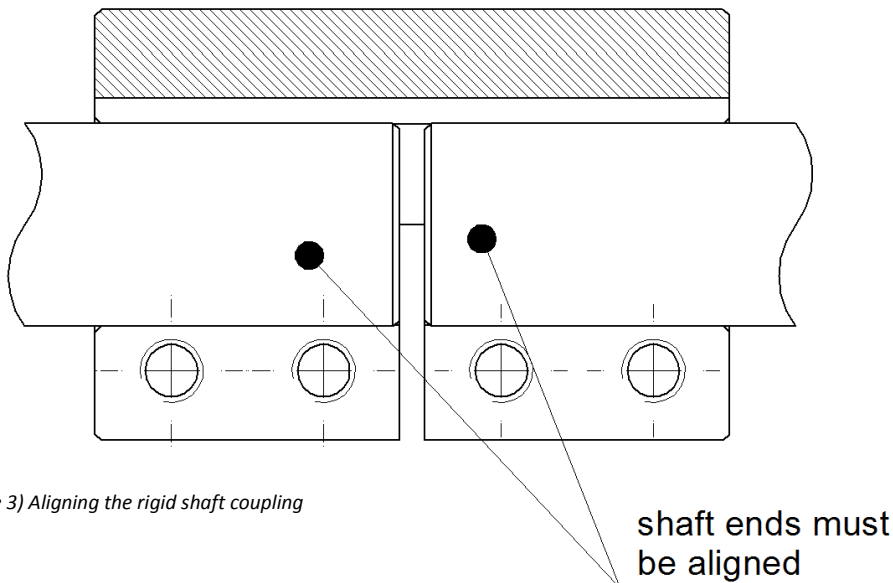

Image 3) Aligning the rigid shaft coupling

- Tighten the clamping screws evenly and in sequence. Increase the tightening torque gradually. Repeat this procedure, until the tightening torque specified in table 1 is reached for all clamping screws.

**Table 1:**

Rigid shaft coupling	KBST-VA						
Size	6	8	10	12	14	15	16
Screw size	M3	M3	M4	M4	M5	M5	M5
Torque $T_A$ [Nm]	1,6	1,6	3,9	3,9	7,6	7,6	7,6

Size	20	25	30	35	40	50
Screw size	M6	M6	M6	M8	M8	M10
Torque $T_A$ [Nm]	13,2	13,2	13,2	32	32	63

**Disassembly of the coupling**



**Danger!**

Loosened or falling drive components can cause personal injury or machine damages. Secure the drive components prior to disassembly.

- Loosen all clamping screws evenly in sequence. (Do not completely unscrew the clamping screws.)



**Attention!**

Non-compliance with these instructions as well as disregarded operating conditions dimensioning the shaft coupling can influence the function of the coupling.

**Disposal:** *Defective shaft couplings must be cleaned and disposed.*