

气动滑台：AXQ 系列

外形尺寸图（毫米）

标准型 AXQ6

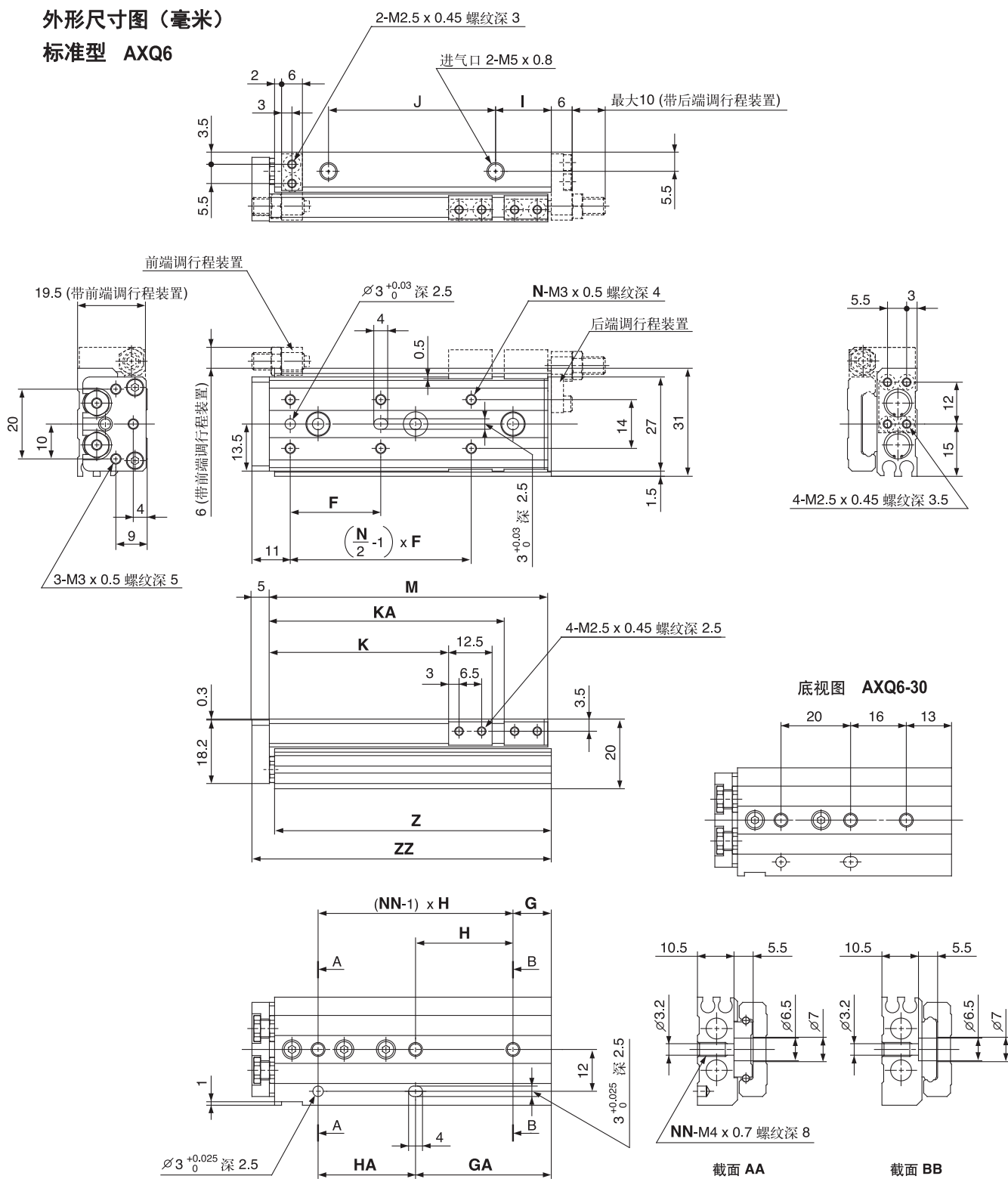

(mm)

型号	F	N	G	H	NN	GA	HA	I	J	K	KA	M	Z	ZZ
AXQ6-10	22	4	6	23	2	13	16	9	17	21.5	—	42	41.5	48
AXQ6-20	25	4	13	26	2	13	26	9	27	31.5	—	52	51.5	58
AXQ6-30	21	6	—	—	3	29	20	9	37	41.5	—	62	61.5	68
AXQ6-40	26	6	11	28	3	39	28	16	48	51.5	67.5	80	79.5	86
AXQ6-50	27	6	21	28	3	49	28	9	65	61.5	77.5	90	89.5	96

对称型 AXQ6L

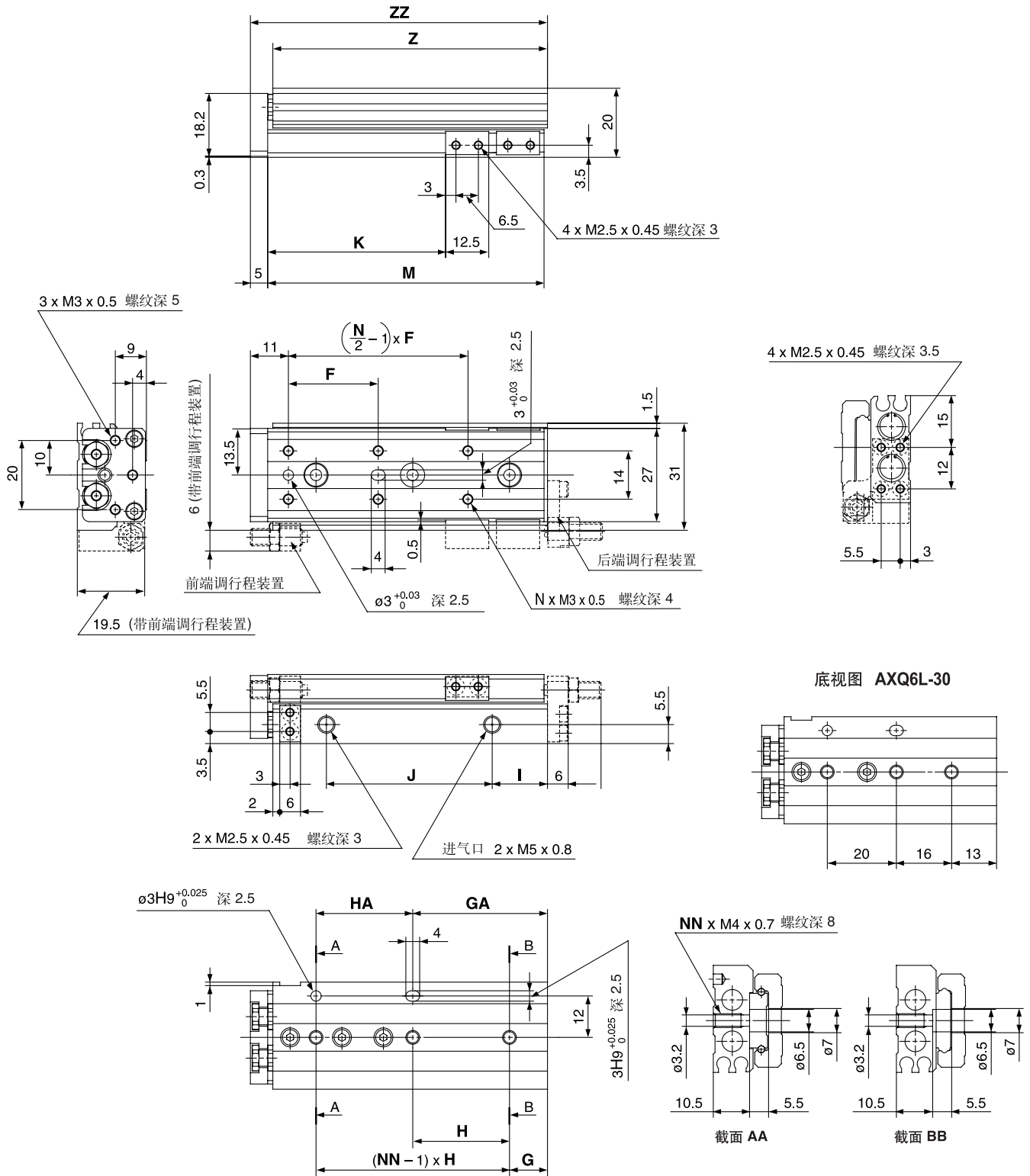

(mm)

Model	F	N	G	H	NN	GA	HA	I	J	K	M	Z	ZZ
AXQ6L-10	22	4	6	23	2	13	16	9	17	21.5	42	41.5	48
AXQ6L-20	25	4	13	26	2	13	26	9	27	31.5	52	51.5	58
AXQ6L-30	21	6	—	—	3	29	20	9	37	41.5	62	61.5	68
AXQ6L-40	26	6	11	28	3	39	28	16	48	51.5	80	79.5	86
AXQ6L-50	27	6	21	28	3	49	28	9	65	61.5	90	89.5	96

标准型 AXQ8

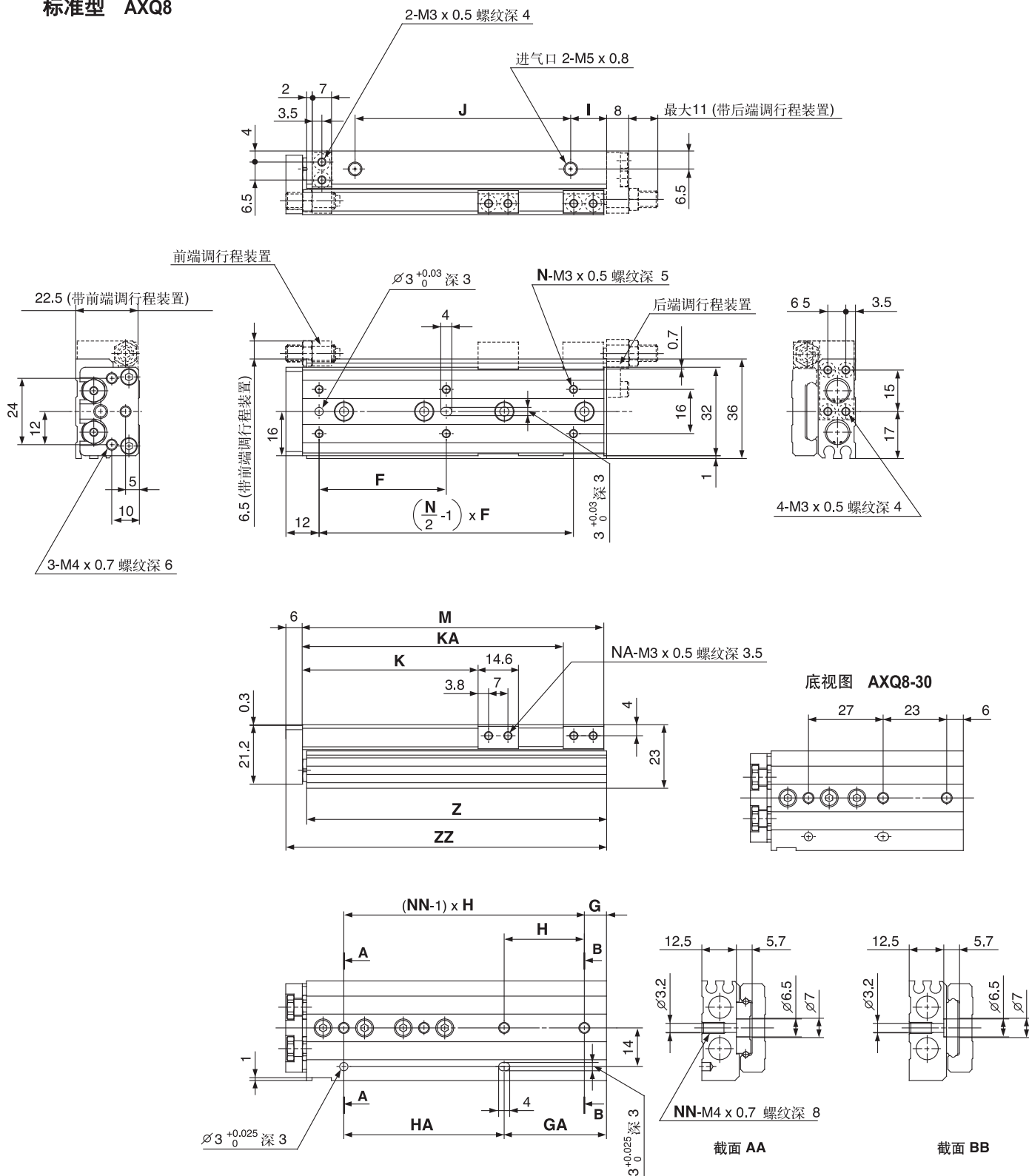

(mm)

型号	F	N	G	H	NN	GA	HA	I	J	K	KA	NA	M	Z	ZZ
AXQ8-10	25	4	7	25	2	13	19	11	17	23.5	—	4	46	45.5	53
AXQ8-20	25	4	14	28	2	14	28	10	28	33.5	—	4	56	55.5	63
AXQ8-30	26	6	—	—	3	29	27	12	40	43.5	—	4	70	69.5	77
AXQ8-40	32	6	8	31	3	39	31	14	52	53.5	69.4	4	84	83.5	91
AXQ8-50	46	6	8	29	4	37	58	13	78	63.5	94.4	8	109	108.5	116
AXQ8-75	50	6	31	30	4	61	60	12	105	88.5	120.4	8	135	134.5	142

对称型 AXQ8L

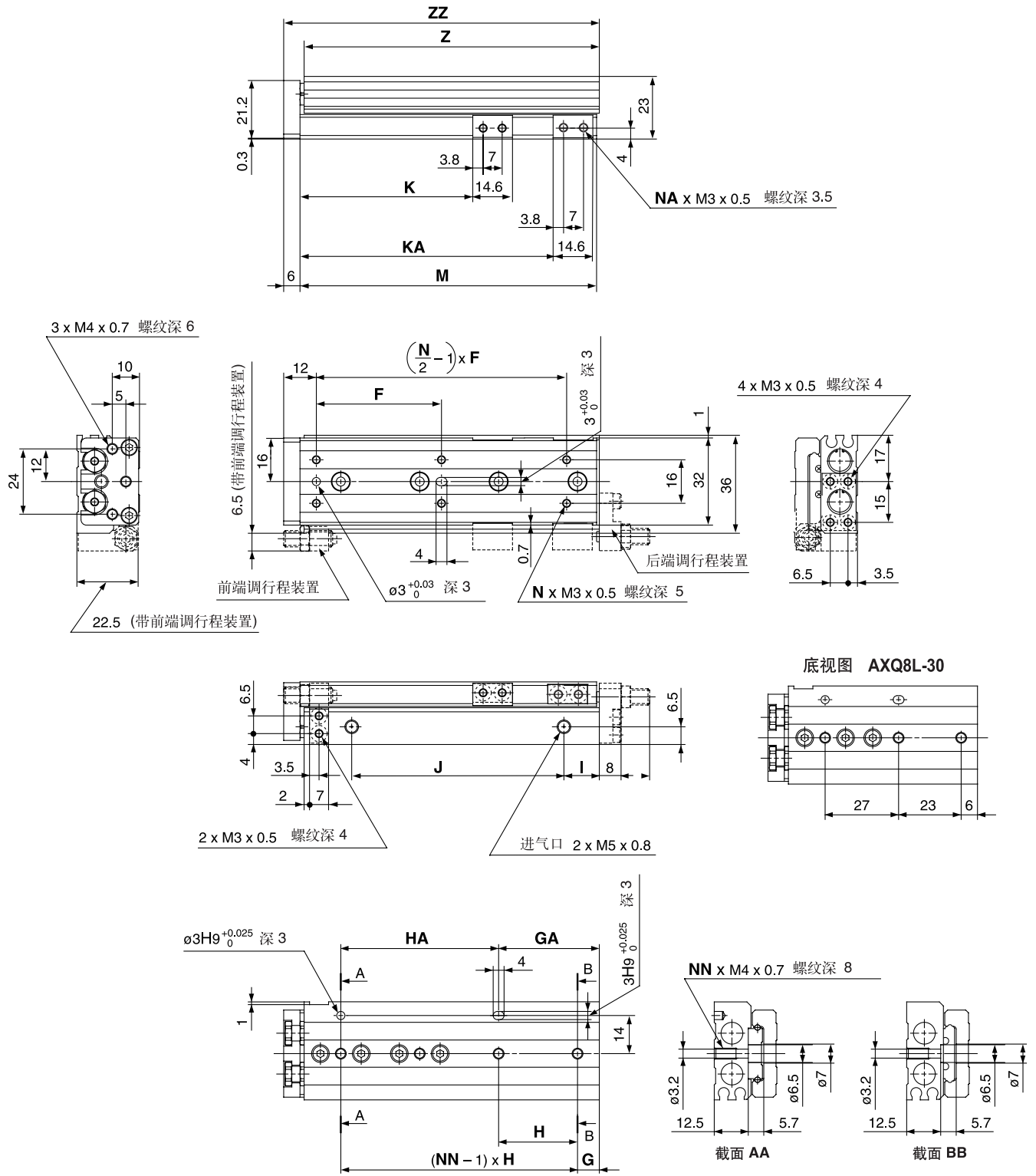

(mm)

型号	F	N	G	H	NN	GA	HA	I	J	K	KA	NA	M	Z	ZZ
AXQ8L-10	25	4	7	25	2	13	19	11	17	23.5	—	4	46	45.5	53
AXQ8L-20	25	4	14	28	2	14	28	10	28	33.5	—	4	56	55.5	63
AXQ8L-30	26	6	—	—	3	29	27	12	40	43.5	—	4	70	69.5	77
AXQ8L-40	32	6	8	31	3	39	31	14	52	53.5	69.4	4	84	83.5	91
AXQ8L-50	46	6	8	29	4	37	58	13	78	63.5	94.4	8	109	108.5	116
AXQ8L-75	50	6	31	30	4	61	60	12	105	88.5	120.4	8	135	134.5	142

标准型 AXQ12

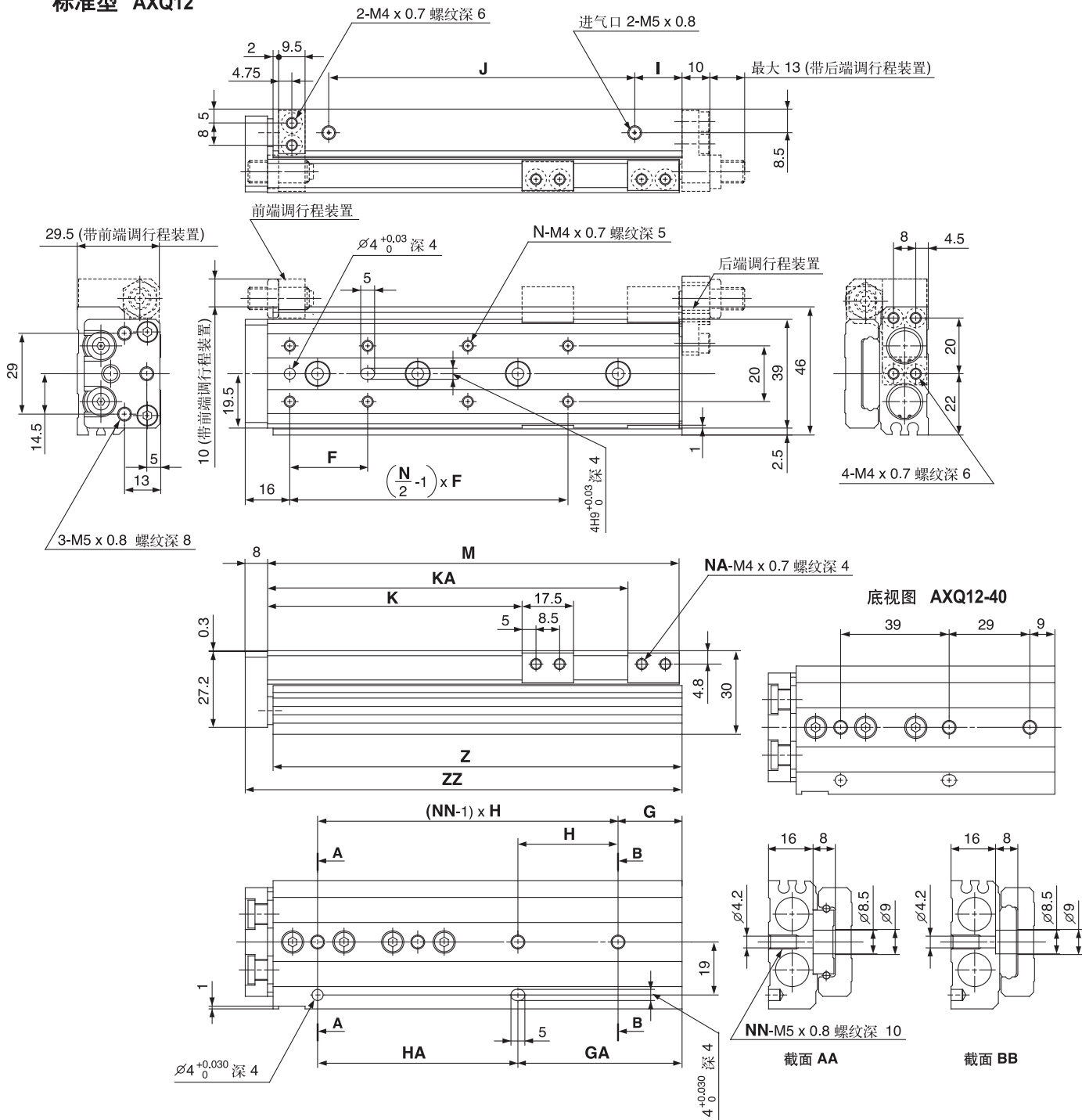

(mm)

型号	F	N	G	H	NN	GA	HA	I	J	K	KA	NA	M	Z	ZZ
AXQ12- 10	28	4	18	32	2	18	32	12	34	27	49	4	67	66	76
AXQ12- 20	28	4	18	32	2	18	32	12	34	37	—	4	67	66	76
AXQ12- 30	38	4	20	40	2	20	40	14	42	47	—	4	77	76	86
AXQ12- 40	34	6	—	—	3	38	39	15	58	57	76	4	94	93	103
AXQ12- 50	34	6	9	39	3	48	39	13	70	67	86	4	104	103	113
AXQ12- 75	36	8	23	36	4	59	72	17	110	92	130	8	148	147	157
AXQ12-100	36	10	12	36	5	84	72	17	135	117	155	8	173	172	182

对称型 AXQ12L

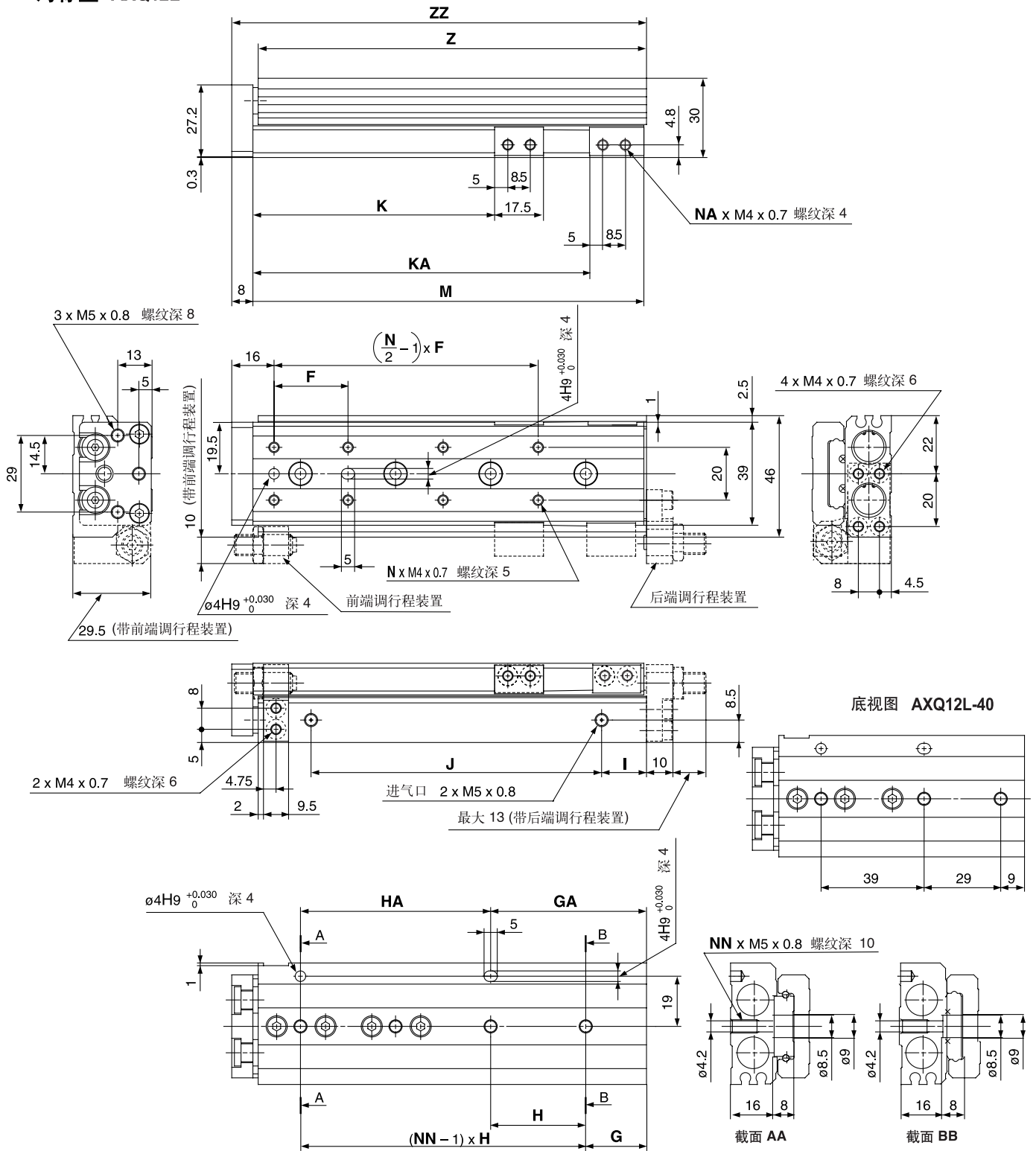

(mm)

型号	F	N	G	H	NN	GA	HA	I	J	K	KA	NA	M	Z	ZZ
AXQ12L- 10	28	4	18	32	2	18	32	12	34	27	49	4	67	66	76
AXQ12L- 20	28	4	18	32	2	18	32	12	34	37	—	4	67	66	76
AXQ12L- 30	38	4	20	40	2	20	40	14	42	47	—	4	77	76	86
AXQ12L- 40	34	6	—	—	3	38	39	15	58	57	76	4	94	93	103
AXQ12L- 50	34	6	9	39	3	48	39	13	70	67	86	4	104	103	113
AXQ12L- 75	36	8	23	36	4	59	72	17	110	92	130	8	148	147	157
AXQ12L-100	36	10	12	36	5	84	72	17	135	117	155	8	173	172	182

标准型 AXQ20

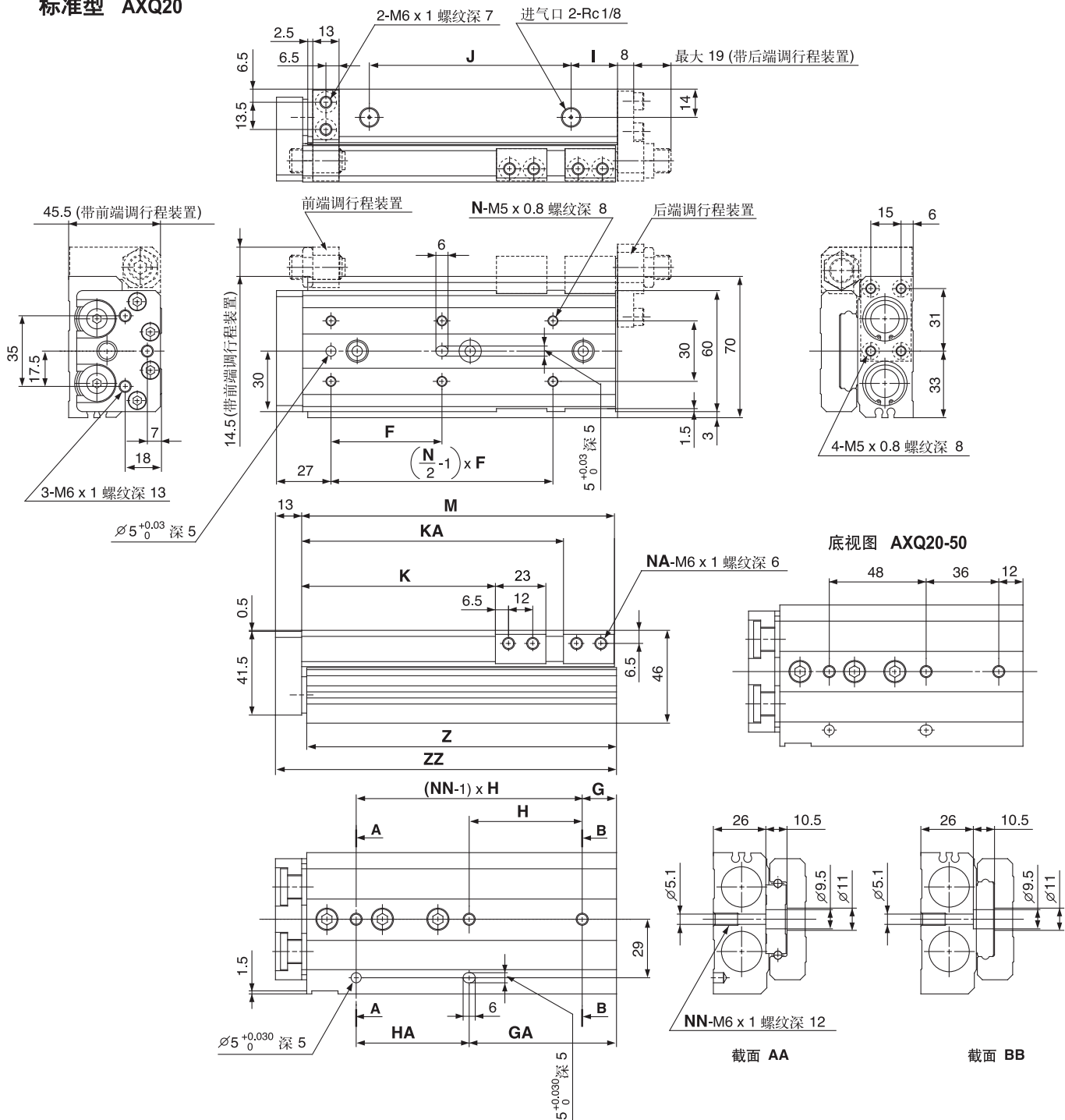

(mm)

型号	F	N	G	H	NN	GA	HA	I	J	K	KA	NA	M	Z	ZZ
AXQ20- 10	45	4	22	46	2	18	50	16	46	32	70	4	94	92.5	108
AXQ20- 20	40	4	22	46	2	18	50	16	46	42	70	4	94	92.5	108
AXQ20- 30	48	4	22	46	2	18	50	16	46	52	—	4	94	92.5	108
AXQ20- 40	58	4	22	56	2	22	56	16	56	62	—	4	104	102.5	118
AXQ20- 50	42	6	—	—	3	48	48	18	72	72	98	4	122	120.5	136
AXQ20- 75	55	6	17	56	3	73	56	23	100	97	131	8	155	153.5	169
AXQ20-100	50	8	18	56	4	74	112	25	155	122	188	8	212	210.5	226
AXQ20-125	55	8	37	59	4	96	118	18	190	147	216	8	240	238.5	254
AXQ20-150	62	8	56	62	4	118	124	21	215	172	244	8	268	266.5	282

对称型 AXQ20L

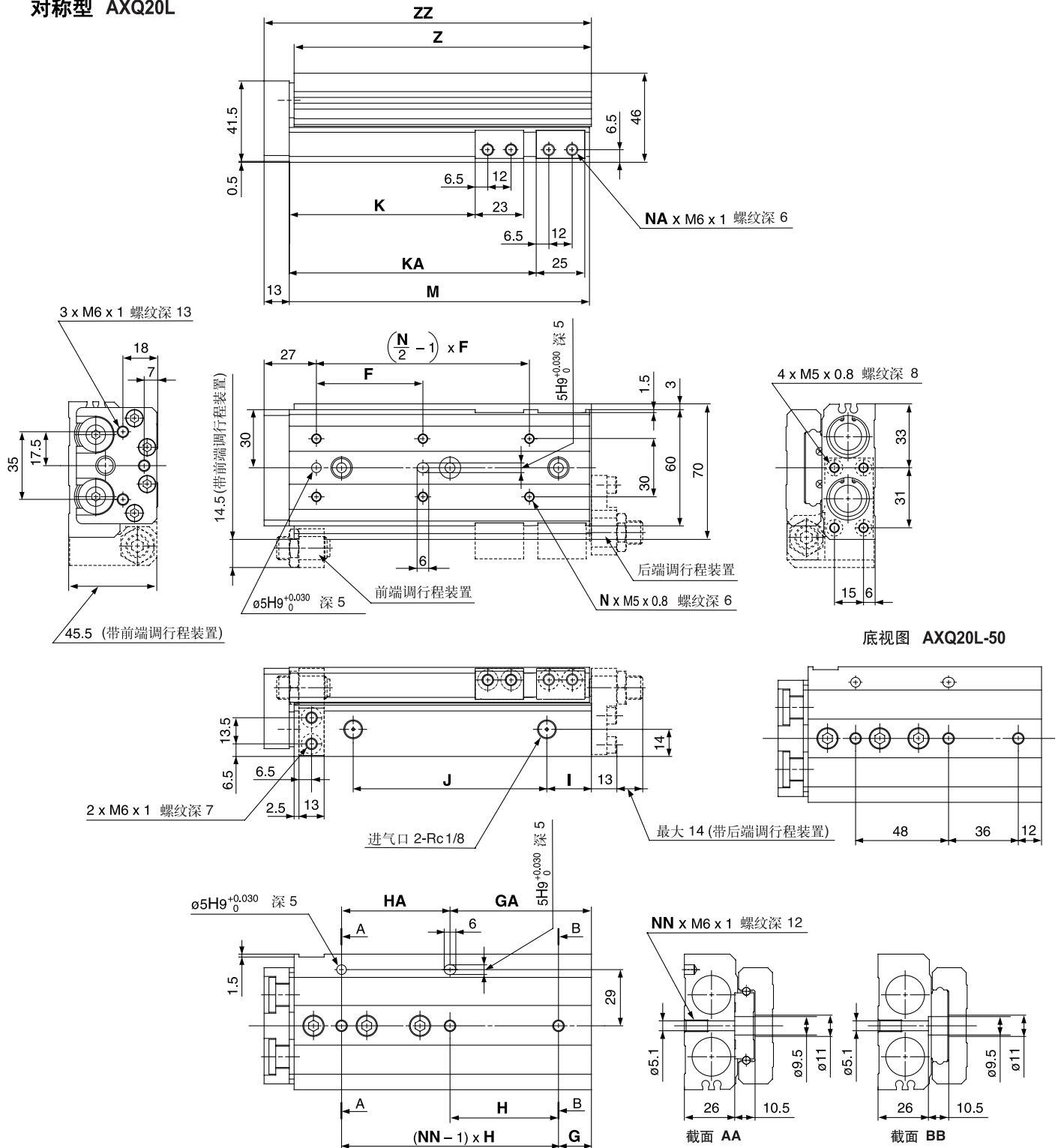

Model	F	N	G	H	NN	GA	HA	I	J	K	KA	NA	M	Z	ZZ
AXQ20L- 10	45	4	22	46	2	18	50	16	46	32	70	4	94	92.5	108
AXQ20L- 20	40	4	22	46	2	18	50	16	46	42	70	4	94	92.5	108
AXQ20L- 30	48	4	22	46	2	18	50	16	46	52	—	4	94	92.5	108
AXQ20L- 40	58	4	22	56	2	22	56	16	56	62	—	4	104	102.5	118
AXQ20L- 50	42	6	—	—	3	48	48	18	72	72	98	4	122	120.5	136
AXQ20L- 75	55	6	17	56	3	73	56	23	100	97	131	8	155	153.5	169
AXQ20L-100	50	8	18	56	4	74	112	25	155	122	188	8	212	210.5	226
AXQ20L-125	55	8	37	59	4	96	118	18	190	147	216	8	240	238.5	254
AXQ20L-150	62	8	56	62	4	118	124	21	215	172	244	8	268	266.5	282

可选功能项

B-带液压缓冲器 AXQ 缸径 - 行程 BS, BT, B

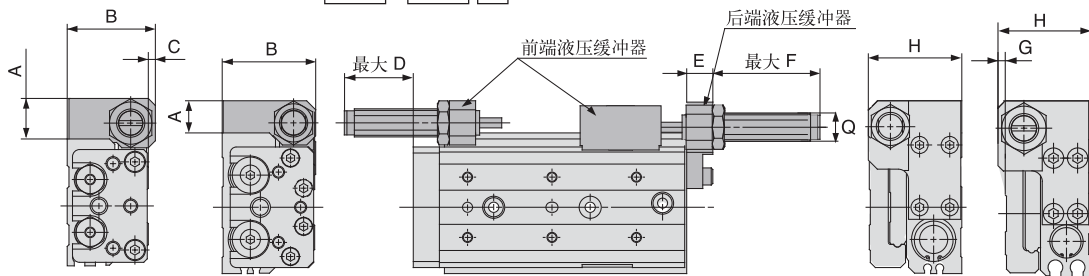

AXQ 8 及 20 AXQ 12•16•25

AXQ 12•16•25 AXQ 8 及 20

带液压缓冲器

(mm)

型号	调节行程范围		A	B	C	D	E	F	G	H	Q
	前	后									
AXQ8	20	20	11.5	25	2	23	8	32	2	25	M8 x 1.0
AXQ12	18	18	10	29.5	-	18	10	30	-	29.5	M8 x 1.0
AXQ16	22	22	12.5	36.5	-	20	12	34	-	36.5	M10 x 1.0
AXQ20	35	35	16	46.5	0.5	35	13	54	0.5	46.5	M14 x 1.5
AXQ25	35	35	16.5	54.5	-	29	15	52	-	54.5	M14 x 1.5