

PL-SERIE

DER KLASSIKER



PL-SERIES THE CLASSIC

Das Zylinderrohr ist achsial durchgehend geschlitzt. Die Kraftabgabe erfolgt über eine Lastkupplung, welche an der Kolbenachse befestigt ist; letztere ist so ausgebildet, dass ein durch den Rohrschlitz geführter Steg den inneren Teil der Kolbenachse mit dem äußeren Teil verbindet.

Der Kraftverlauf ist also:

Luftdruck → Kolbenfläche → Kolbenachse (innen) Kolbenachse (außen) → Lastkupplung → Werkstück.

Die druckfeste Abdichtung des Zylinderschlitzes wird mit einem präzisionsgeschliffenen, innen liegenden Stahlband erreicht; dieses wird mit 2 längs des Schlitzes verlaufenden Magnetstreifen in Position gehalten.

Ein zweites Stahlband befindet sich außen auf dem Schlitz des Rohres. Es dient der Staubabdeckung. Beide Stahlbänder werden während der Kolbenfahrt genauso wie bei Stillstand hinter der Kolbenabdichtung vom Schlitz abgehoben und jeweils mittels eines eigenen Führungskanals durch die Kolbenachse geleitet. Davor und dahinter legen sich die Bänder wieder dichtend über den Zylinderschlitz.

The entire tube is slotted throughout its full length. The force is transmitted through the load friction, which is attached to the piston axle.

The design of the piston axle is that way that the inner part of the piston axle is connected through the slot with the outer part of it.

Therefore the force transmission runs as follows:

Air pressure → Piston area → piston axle (inner part) → piston axle (outer part) → load friction → load.

The sealing of the cylinder slot is guaranteed by a most precisely grinded inner steel band. The inner band is kept in position due to magnet stripes which are placed on both sides of the slot. In addition there is an outer steel band covering the slot in order to keep dust out of inner space of the cylinder.

During piston movement as well as during stillstand of it both steelbands are lifted right after the piston seal and led through the piston axle by means of a separate own guiding channel. Before and behind the piston axle both bands are covering the slot permanently again.

VORZÜGE / BENEFITS

- Gleiche Kräfte in beiden Richtungen
- Kraftabgabe direkt, verdrehgesichert
- Kolben wahlweise mit oder ohne Magnet
- Halbierte Einbaulänge – raumsparend
- Extreme Hublänge bis zu 5700mm
- 3facher Luftanschluss, Endlagendämpfung beidseitig, einstellbar
- Hohe Beschleunigungen und Geschwindigkeiten
- Hoher konstruktiver Freiheitsgrad
- Betrieb mit geölter oder ungeölter Luft **)
- 3-Stufige Dämpfungscharakteristik zur Schonung von Dämpf- und Lastsystem*)
- Einsatz in EX-Bereich möglich - ATEX

*) Sonderausführung auf Anfrage.

**) Achtung: Vorangegangene Inbetriebnahme mit geölter Luft schließt die Umstellung auf nicht geölte Luft ohne vorherige Demontage, Reinigung und Nachfettung (Grundfettschmierung) des Zylinders aus.

- Equal forces on both ends of the piston
- Force connection direct, torque safe
- Piston with or without magnets
- 50% space-savings
- Long strokes up to 5700mm
- End caps with 3 air connections and adjustable cushioning
- Fast acceleration and high piston velocity
- Very flexible in the user`s design
- Non lubricated or lubricated air supply**)
- 3 stage cushioning characteristics for protection of the cushioning- and loadsystem *)
- Use in EX area possible - ATEX

*) Special Version On request

**) Attention: Before changing operation from lubricated to nonlubricated air the cylinder has to be disassembled, cleaned, newly greased and reassembled

TECHNISCHE DATEN / TECHNICAL DATA

Bauart	Kolbenstangenloser Zylinder, doppelwirkend mit direkter Kraftübertragung	Design	Rodless cylinder, double acting, direct force transmission
Hublängen		Strokes	
ø 25-40 mm	100-5700mm, stufenlos je 1mm (längere Hübe auf Anfrage)	ø 25-40 mm	100-5700mm, in increments of 1mm (longer strokes on request)
ø 16 mm	100-4400mm, stufenlos je 1mm	ø 16 mm	100-4400mm, in increments of 1mm
Anschlussgewinde	(M5, G 1/8", G 1/4", g3/8")	Air connection	(M5, G 1/8", G 1/4", g3/8")
Einbaulage	beliebig	Mounting	free
Kräfte + Momente	Siehe Kräfte und Momente	Forces + moments	see Forces and moments
Stützkräfte	Siehe Stützdiagramm	Support Forces	see Deflection Diagram
Temperaturen	-10°C bis +80°C andere Temperaturbereiche auf Anfrage	Temperatures	(-10°C bis +80°C) other temperatures on request
Werkstoffe		Materials	
Profilrohr	Aluminium hochfest anodisiert	Barrel	High-strength anodized aluminum
Zylinderköpfe	Aluminium hochfest anodisiert	End caps	High-strength anodized aluminum
Kolbenachse	Aluminium hochfest anodisiert	Piston axle	High-strength anodized aluminum
Dichtungen	Ölbeständiger Kunststoff(V < 1m/s (NBR)(V > 1m/s (VITON)	Seals	Oilproof synthetic material (V < 1m/s (NBR)(V > 1m/s (VITON)
Dichtbänder	Edelstahl	Sealing bands	Stainless steel
Kolbenkappen	abriebfester Kunststoff	Piston caps	Wear proof synthetic material
Gleitteile	abriebfester Kunststoff	Sliding parts	Wear proof synthetic material
Betriebsdruck	0,5-8,0 bar	Pressure range	0,5-8,0 bar
Medium	Gefilterte Druckluft, Max. 50 µm	Medium	compressed air, filtered max. 50µm

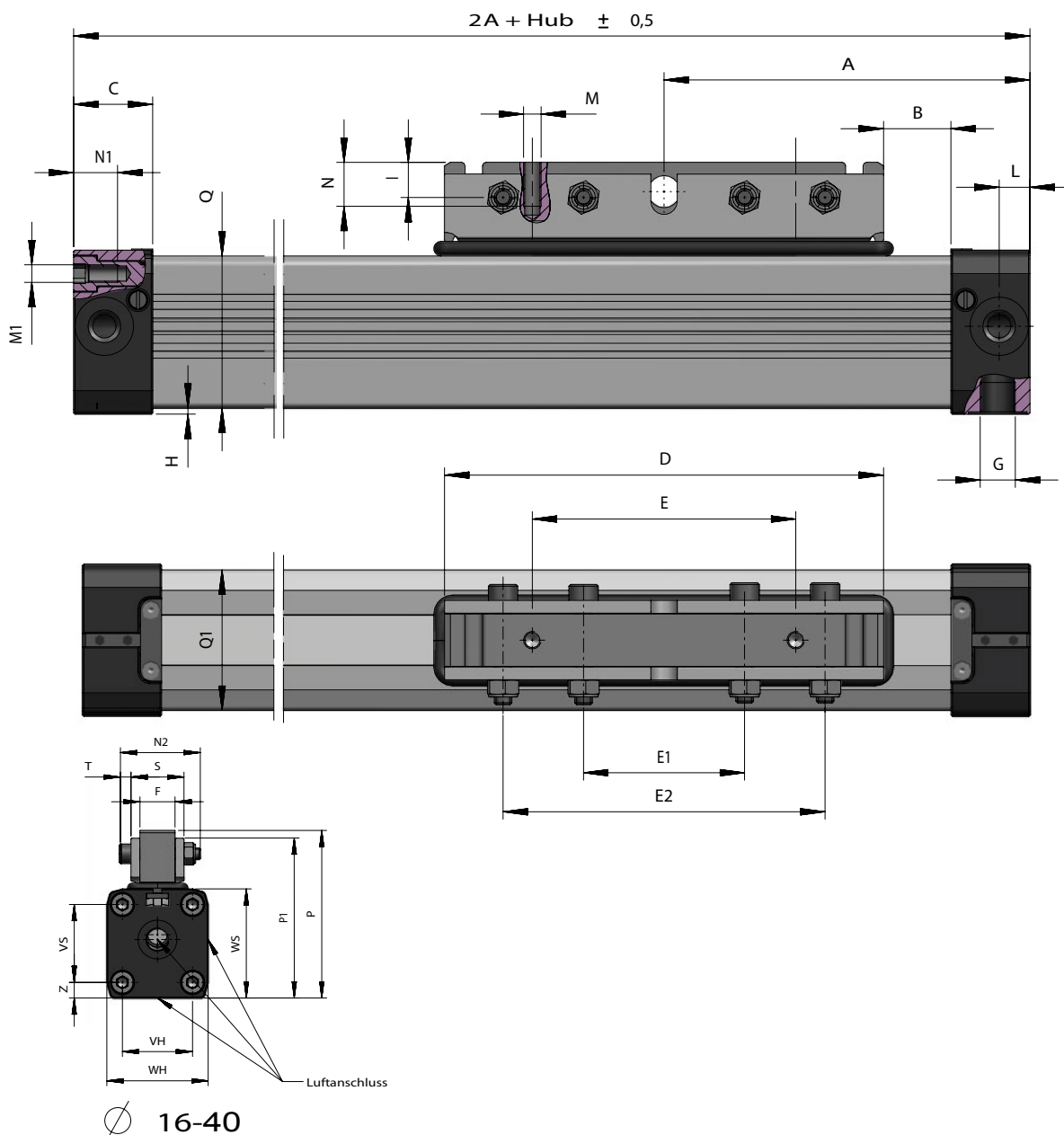

DIMENSIONEN / DIMENSIONS

Ø	A	B	C	D	E	E1	F	G	I	L	M	M1	N1	N2	P-P1
16	65	12	15	76	48	32	10	M5	6	5,5	M4	M3	7	27	43,5 - 42,3
16L	90	37	15	76	48	32	10	M5	6	5,5	M4	M3	7	27	43,5 - 42,3
25	100	17	23	120	80	50	15	1/8"	13	8,5	M5	M5	10	35	66-58
25L	150	67	23	120	80	50	15	1/8"	13	8,5	M5	M5	10	35	66-58
32	125	23	27	150	90	55	18	1/4"	12	10,5	M6	M6	14	41	86-82
32L	200	23	27	300	180	120	18	1/4"	12	10,5	M6	M6	14	41	86-82
40	150	45	30	150	90	55	18	1/4"	12	15	M6	M6	17	41	97-93
40L	250	70	30	300	180	120	18	1/4"	12	15	M6	M6	17	41	97-93

Ø	P1	QxQ1	E2	H	S	T	VH	WH	VS	WS	Z
16	37,5	24,5x25	64	1,0	18	4	18	27	18	27	4,5
16L	37,5	24,5x25	64	1,0	18	4	18	27	18	27	4,5
25	53	36x36	100	2	23	5	27	40	27	40	6,5
25L	53	36x36	100	2	23	5	27	40	27	40	6,5
32	74	52x51	110	2	27	6	36	52	40	56	8
32L	74	52x51	240	2	27	6	36	52	40	56	8
40	85	58,5x59	110	7	28	6	54	72	54	69	9
40L	85	58,5x59	240	7	28	6	54	72	54	69	9

- 16L – 40L : Kolbenausführung LANG für schwere Biege- und Torsionsmomente, auch bei senkrechter Bewegung zu empfehlen
- P1: variabel je Bedarf/Standardmaße zuerst genannt

- 16L – 40L : Cylinder with long-piston for heavy bending and torque moments.
- P1: variable on request/details for standard Dimension is mentioned first

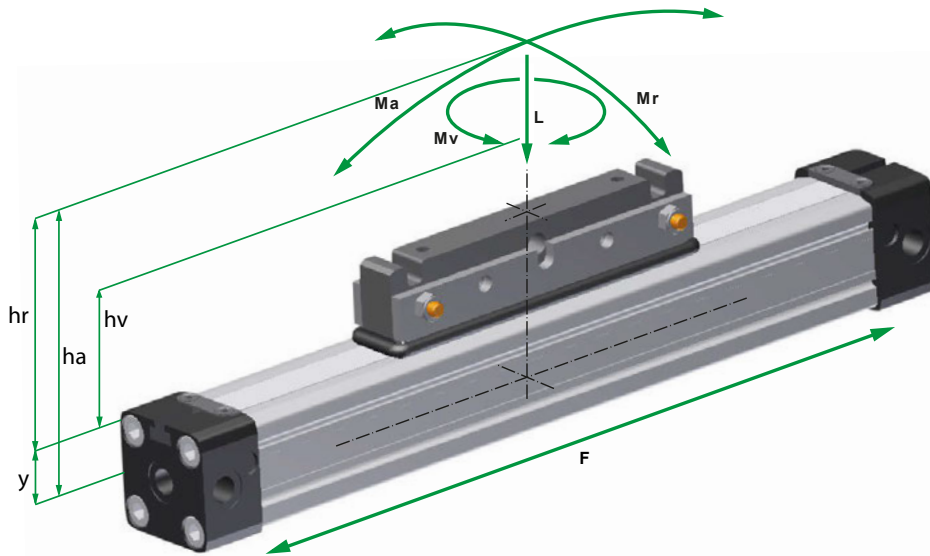

**FORMELN /
FORMULAS**

$$M_a = F * h_a$$

$$M_r = F * h_r$$

$$M_v = F * h_v$$

KRÄFTE UND MOMENTE

Zylinder		Kolbenkraft (N)	Dämpfung	Max. Belastung (N)	Max. Biegemoment (Nm)		Max. Verdrehmoment (Nm)
		Bei 6 Bar	(mm)	PL	PL		PL
Ø	Y	F	S	L	Ma axial	Mr radial	Mv zentral
16	9	110	15	120	4	0,3	0,5
25	14	250	21	300	15	1,0	3,0
32	18	420	26	450	30	2,0	4,5
40	22	640	32	750	60	4,0	8,0

FORCES AND MOMENTS

Cylinder		Effect Force (N)	Cushioning	Max. allowed load (N)	Max. allowed bending moments (Nm)		Max. allowed torque (Nm)
		at 6 Bar	(mm)	PL	PL		PL
Ø	Y	F	S	L	Ma axial	Mr radial	Mv zentral
16	9	110	15	120	4	0,3	0,3
25	14	250	21	300	15	1,0	3,0
32	18	420	26	450	30	2,0	4,5
40	22	640	32	750	60	4,0	8,0

Die Tabellenangaben stellen die höchstzulässigen Werte bei stoßfreiem Betrieb und Geschwindigkeiten von $v \leq 0,2\text{m/sec}$ [PL-Serie] – $v \leq 0,45\text{m/sec}$ [PLF-Serie] dar. Max. 6 bar. Eine Überschreitung, auch kurzfristig, der Werte im dynamischen Bereich ist unzulässig.

Achtung: Im grenznahen Einsatzfall können resultierende Kräfte zu einer Überschreitung der zulässigen Grenzwerte führen. Bei undefinierbaren Situationen ist daher eine Unterschreitung der zulässigen Belastungswerte um 10–20% notwendig.

Bitte fragen Sie unseren Außendienst.

The figures above are max. values based on light shock free duty and speed of $v \leq 0,2\text{m/sec}$ [PL-series] – $v \leq 0,45\text{m/sec}$ [PLF-series]. Max. pressure 6 bar. An exceeding of the values in dynamic operations, even for short moments, has to be avoided.

Attention: Resulting forces could lead to extreme exceedings of the values. In case of undefinable situations the above max. values have to be underrun by 10–20%.

Please ask our sales representatives

DÄMPFUNGS-DIAGRAMM / CUSHIONING DIAGRAM

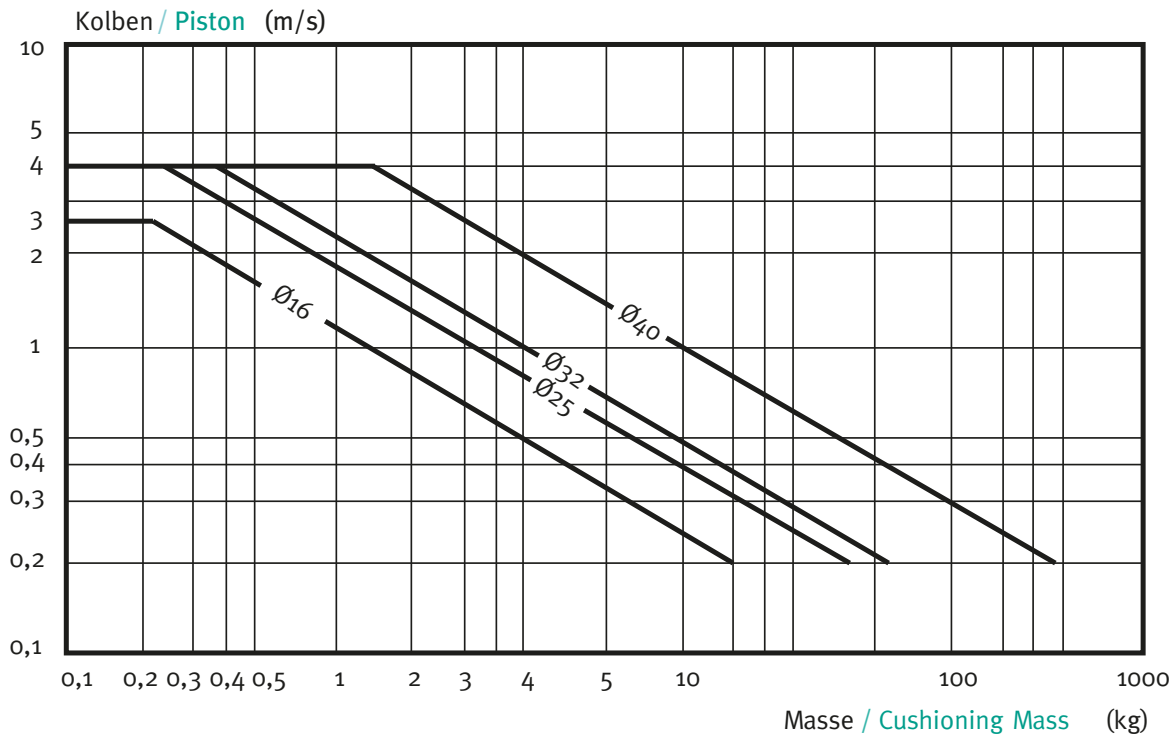

Bitte beachten Sie:

- Bei Überschreitung der zulässigen Grenzwerte müssen externe Stoßdämpfer eingebaut werden.
- Bei Kolbengeschwindigkeiten $\geq 1\text{m/s}$ werden Vitondichtungen empfohlen.
- Bei Kolbengeschwindigkeiten $\leq 0,1\text{m/s}$ (NBR), $\leq 0,2\text{m/s}$ (VITON) wird Spezialfett Nr. IX empfohlen, siehe Ersatzteile.
- Bei Kolbengeschwindigkeiten unter 1m/s wird eine optimale Lebensdauer erreicht.

Pay attention to the following points:

- If the limits above are exceeded additional shock absorbers are necessary.
- For piston speeds of more than $\geq 1\text{m/s}$ viton seals are recommended.
- For piston speeds $\leq 0,1\text{m/s}$ (NBR), $\leq 0,2\text{m/s}$ (VITON) slow speed lubrication is necessary see at sperpart kids
- Maximum duration life will be achieved when piston speeds do not exceed 1m/s .

STÜTZLÄNGEN-DIAGRAMM / DEFLECTION DIAGRAM



Diagramm-Information:

- Rechnerische Durchbiegungen ohne Unterstützung von 0,5 – 1mm ermöglichen größere Stützlänge.
- Rechnerische Durchbiegungen ohne Unterstützung von 1 – max. 1,5mm erfordern geringere Stützlänge.

Diagram Information:

- Calculated deflections without support of 0,5 – 1mm allow exceeding of supporting distance.
- Calculated deflections without support of 1mm – max 1,5mm require reduction of the supporting distance.

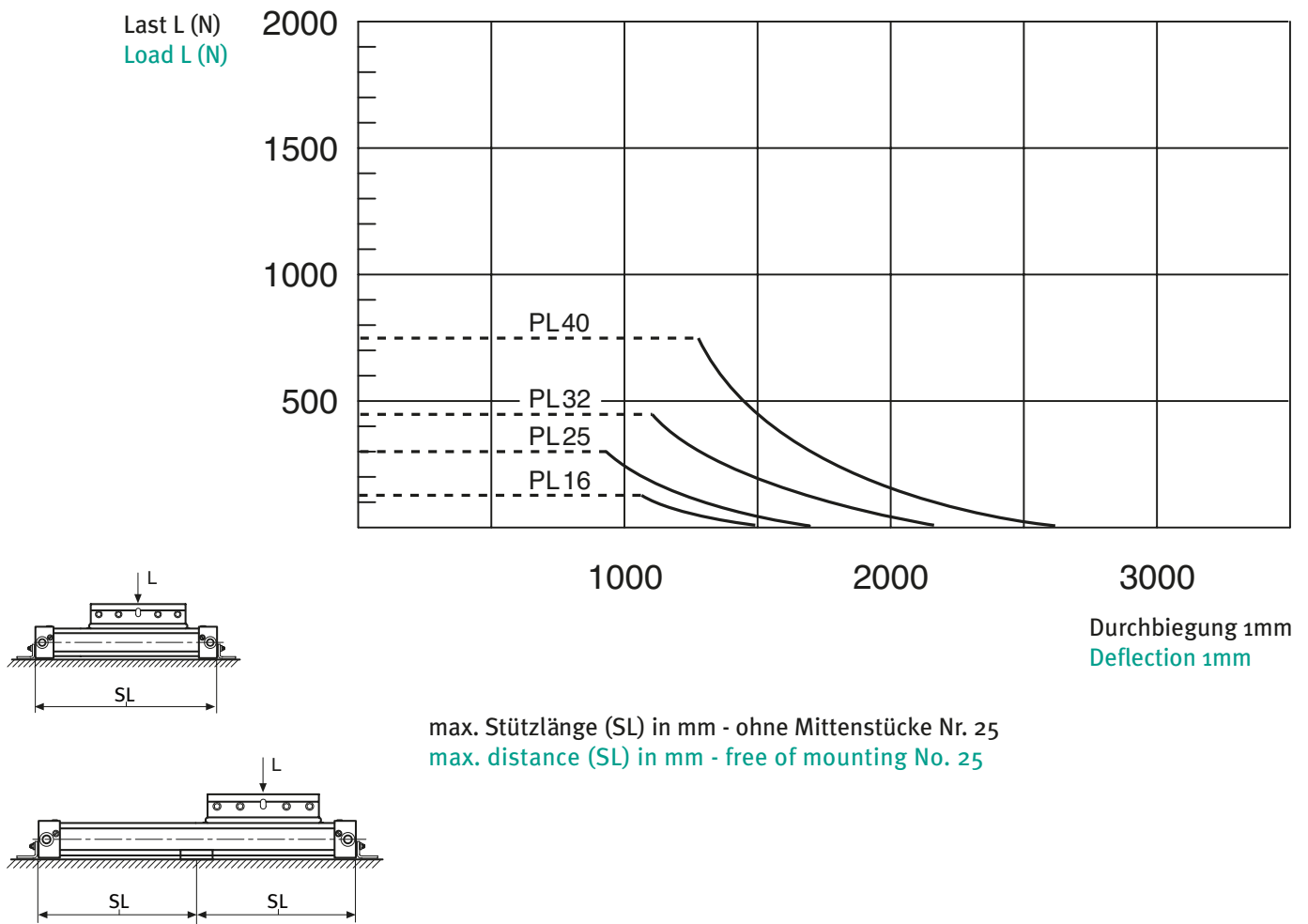
ANBAUTEILE / MOUNTINGS

ZYLINDER-KOPFBEFESTIGUNG / END COVER BRACKET (FOOT)

24/1.0 - 2.0*

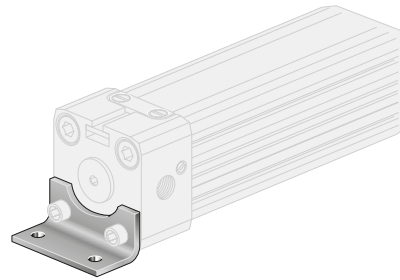
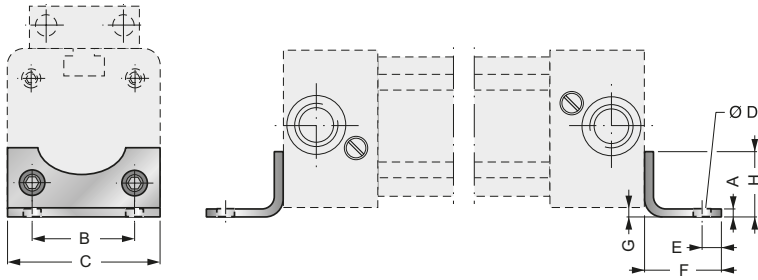

24/3.0 - 4.0*

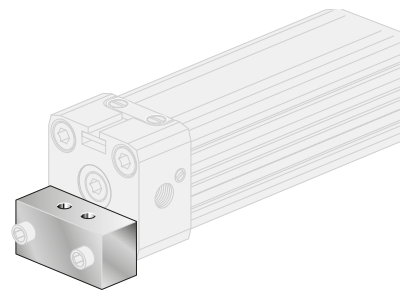
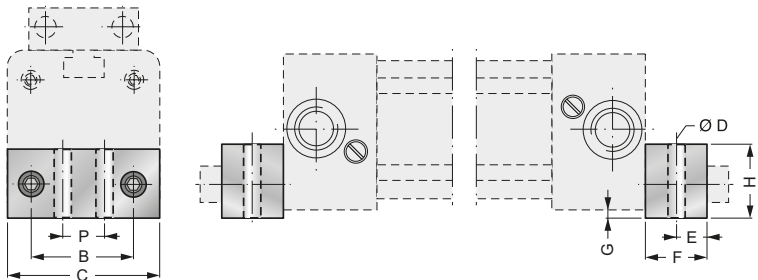

ZYLINDER-STÜTZBEFESTIGUNG / MID SECTION SUPPORT

25/1.0 - 2.0*

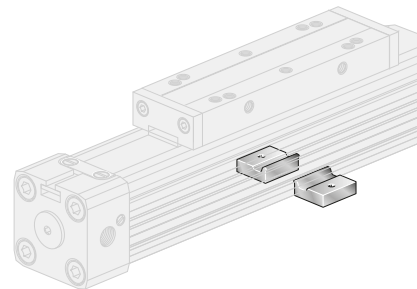
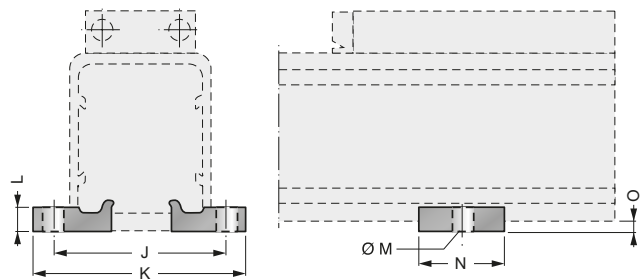

25/3.0 - 4.0*

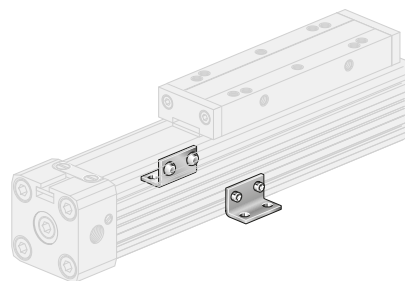
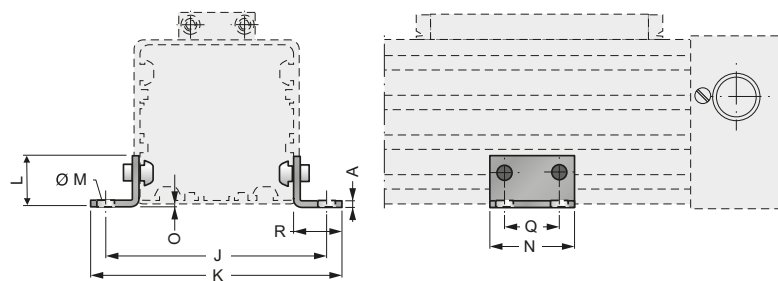

*)Anwendungsbereiche / Application No.

24/1.0 = Ø16	24/2.0 = Ø25
24/3.0 = Ø32	24/4.0 = Ø40
25/1.0 = Ø16	25/2.0 = Ø25
25/3.0 = Ø32	25/4.0 = Ø40

Ø	A	B	C	D	E	F	G	H	J	K	L	M	N	O	P	Q	R
16	1,5	18	26	3,6	4,0	14	1,5	12,5	41,5	53,5	5	Ø5,5	20	3	-	-	-
25	2,5	27	40	5,5	6,0	22	2	18	48,5	60	6	Ø5,5	20	4	-	-	-
32	5,0	36	51	6,5	8,0	24	4	20	82	91	30	Ø4,5	45	6	20	30	20
40	5,0	54	71	9	11,5	24	2	20	90	99	25	Ø4,5	45	8,5	30	30	20

MOBILE ZYLINDER MITTELSTÜTZE, VERSION G FÜR ZYLINDER Ø25/32

MOBILE MID SECTION SUPPORT, TYPE G FOR CYLINDER Ø25/32

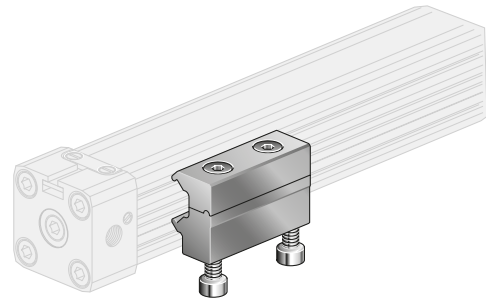
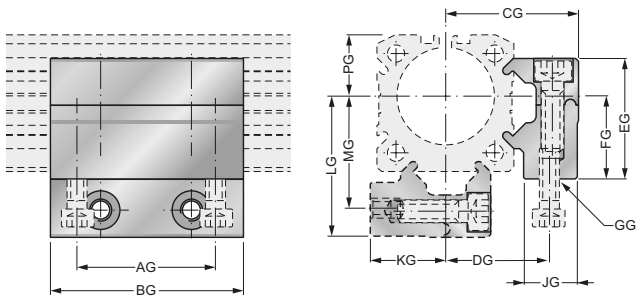

ø	AG	BG	CG	DG	EG	FG	GG	JG	KG	LG	MG	PG
16	18,0	30,0	27,5	18,4	21,0	15,0	M4	11,5	13,9	29,0	19,7	10,8
25	36,0	50,0	34,5	27,0	31,3	22,0	M5	14,0	20,0	36,5	29,0	16,0
32	36,0	50,0	41,8	34,2	39,0	30,0	M6	14,0	27,6	47,0	39,5	21,5

MOBILE ZYLINDER MITTELSTÜTZE, VERSION W FÜR ZYLINDER Ø25/32

MOBILE MID SECTION SUPPORT, TYPE W FOR CYLINDER Ø25/32

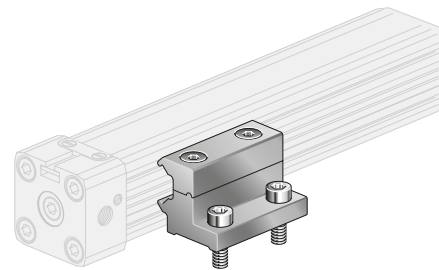
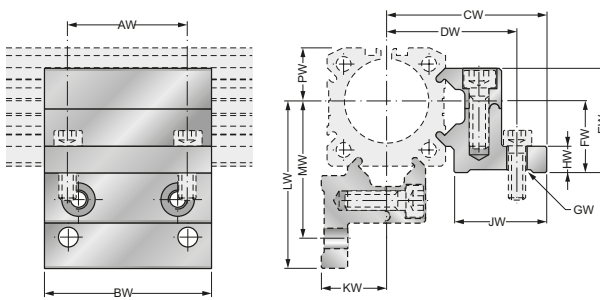

ø	AW	BW	CW	DW	EW	FW	GW	HW	JW	KW	LW	MW	PW
16	18,0	30,0	37,0	32,5	21,0	15,0	Ø4,5	6,0	22,4	13,9	38,0	32,9	10,8
25	36,0	50,0	47,5	40,0	31,3	22,0	Ø5,5	10,0	26,0	20,0	49,5	42,0	16,0
32	36,0	50,0	56,0	47,4	39,0	30,0	Ø6,5	10,0	28,5	27,6	61,0	52,5	21,5

ANBAUTEILE / MOUNTINGS

LASTKUPPLUNG BEWEGLICH / ARTICULATED CARRIER

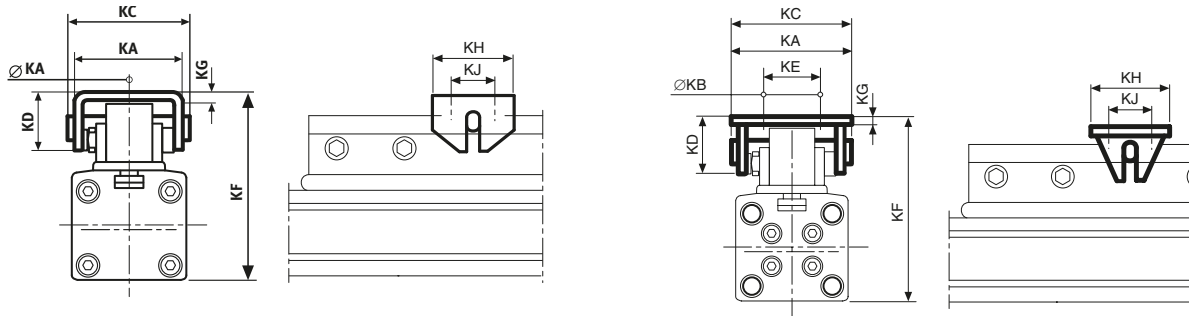

T-LASTKUPPLUNG / T-LOAD

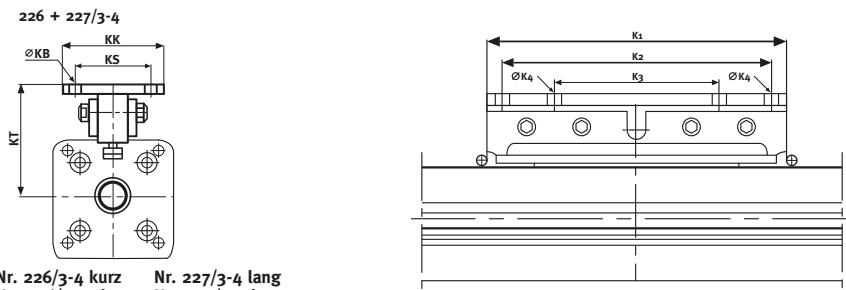

Nr. 226/3-4 kurz Nr. 227/3-4 lang
 No. 226/3-4 short No. 227/3-4 long

ø	KA	KB	KC	KD	KE	KF*	KG	KH	KJ	KK	KS	KT	K ₁	K ₂	K ₃	K ₄
16	25	4,5	28	12	-	47-50	2	20	10	-	-	-	-	-	-	-
25	37	5,5	42	20	-	72-75	3	30	16	-	-	-	-	-	-	-
32	70	7,0	70	38	55	91-100	5	90	75	60	45	58,5	150	-	80	7
32L	-	7,0	-	-	-	-	-	-	-	60	45	58,5	300	160	80	7
40	70	7,0	70	38	55	111-120	5	90	75	60	45	63	150	-	80	7
40L	-	7,0	-	-	-	-	-	-	-	60	45	63	300	160	80	7

■ * KF-Maße sind innerhalb der freien Gabeltiefe der Lastkupplung variabel.

■ * KF-Dimensions are variable within the length of the slot of the load friction.

ZYLINDER / CYLINDER

- Stellenangaben bei Hubfestlegung (0100-5700 mm)
- Ident-figures for stroke definition (0100-5700 mm)



Ø 16-40MM - PL 16-40/00-22

Typen	Ident.-Nr.	Ausführungen	Types	Ident.-No.	Description
PL 16/00 PL 25/00 PL 32/00 PL 40/00	11.690. •••• 12.590. •••• 13.190. •••• 14.190. ••••	Standard 00: v=1 m/s starre Lastkupplung NBR-Dichtungen Schrauben 10.9 verzinkt 3-dach Luftanschluss	PL 16/00 PL 25/00 PL 32/00 PL 40/00	11.690. •••• 12.590. •••• 13.190. •••• 14.190. ••••	Standard 00: v=1 m/s Regid load connection NBR-seals screws 10.9 zinc plated 3-air connections
PL 16/01 PL 25/01 PL 32/01 PL 40/01	11.680. •••• 12.580. •••• 13.180. •••• 14.180. ••••	Speziell 01: wie Standard 00, jedoch Schrauben rostfrei	PL 16/01 PL 25/01 PL 32/01 PL 40/01	11.680. •••• 12.580. •••• 13.180. •••• 14.180. ••••	Special 01: as Standard 00, but screws stainless steel
PL 16/02 PL 25/02 PL 32/02 PL 40/02	11.670. •••• 12.570. •••• 13.170. •••• 14.170. ••••	Speziell 02: wie Standard 00, jedoch v=1 m/s Viton-Dichtungen	PL 16/02 PL 25/02 PL 32/02 PL 40/02	11.670. •••• 12.570. •••• 13.170. •••• 14.170. ••••	Special 02: as Standard 00, but v=1 m/s Viton-seals
PL 16/03 PL 25/03 PL 32/03 PL 40/03	11.660. •••• 12.560. •••• 13.160. •••• 14.160. ••••	Speziell 03: wie Standard 00, jedoch v=1 m/s Viton-Dichtungen Schrauben rostfrei	PL 16/03 PL 25/03 PL 32/03 PL 40/03	11.660. •••• 12.560. •••• 13.160. •••• 14.160. ••••	Special 03: as Standard 00, but v=1 m/s Viton-seals screws stainless steel
PL 32/05 PL 40/05	13.195. •••• 14.195. ••••	Speziell 05: wie Standard 00, jedoch T-Lastkupplung kurz, mit 2 Anschlussbohrungen	PL 32/05 PL 40/05	13.195. •••• 14.195. ••••	Special 05: as Standard 00, but T-load connection short, with 2 connection bores
PL 32/09 PL 40/09	13.199. •••• 14.199. ••••	Speziell 09: wie Standard 00, jedoch T-Lastkupplung lang, mit 4 Anschlussbohrungen	PL 32/09 PL 40/09	13.199. •••• 14.199. ••••	Special 09: as Standard 00, but T-load connection long, with 4 connection bores
PL 16/10 PL 25/10 PL 32/10 PL 40/10	11.698. •••• 12.598. •••• 13.198. •••• 14.198. ••••	Standard 10: langer Kolben bei Senkrechtfahrt emp- fohlen	PL 16/10 PL 25/10 PL 32/10 PL 40/10	11.698. •••• 12.598. •••• 13.198. •••• 14.198. ••••	Standard 10: long piston recommended for vertical movement

Ø 16-40MM - PL 16-40/20-22

Typen	Ident.-Nr.	Ausführungen	Types	Ident.-No.	Description
PL 16/20 PL 25/20 PL 32/20 PL 40/20	11.692. •••• 12.592. •••• 13.192. •••• 14.192. ••••	Standard 20: v=1 m/s bewegliche Lastkupplung NBR-Dichtungen Schrauben 10.9 verzinkt 3-fach Luftanschluss	PL 16/20 PL 25/20 PL 32/20 PL 40/20	11.692. •••• 12.592. •••• 13.192. •••• 14.192. ••••	Standard 20: v=1 m/s flexible load connection NBR-seals screws 10.9 zinc plated 3-air connections
PL 16/22 PL 25/22 PL 32/22 PL 40/22	11.672. •••• 12.572. •••• 13.172. •••• 14.172. ••••	Speziell 22: wie Standard 20, jedoch v=1 M/S Viton-Dichtungen	PL 16/22 PL 25/22 PL 32/22 PL 40/22	11.672. •••• 12.572. •••• 13.172. •••• 14.172. ••••	Special 22: flexible load connection v=1 m/s VITON-seals

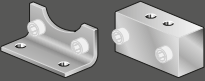
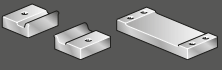
ZYLINDER - BEFESTIGUNG / CYLINDER MOUNTINGS

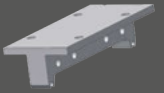
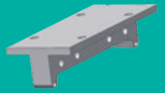
Typen	Ident.-Nr.	Zyl. -Ø	Ausführungen	Types	Ident.-No.	Zyl. -Ø	Description
Zylinderbefestigungen 24/1.0 24/2.0 24/3.0 24/4.0 24/3.1 	89.581.0001 89.582.0001 89.583.0001 89.584.0001 89.583.2011	PL 16 PL 25 PL 32 PL 40 PL 32	Befestigungssatz 24/.. 2 Befestigungen 4 Schrauben 10.9 verzinkt nach DIN 912 Befestigung 24 für PL 32 hochkant	Cylinder mounting 24/1.0 24/2.0 24/3.0 24/4.0 24/3.1 	89.581.0001 89.582.0001 89.583.0001 89.584.0001 89.583.2011	PL 16 PL 25 PL 32 PL 40 PL 32	Connection set 24/.. 2 brackets 4 screws 10.9 zinc plated acc. DIN 912 Connection set for PL 32 upright
Zylinderbefestigungen 25/1.0 25/2.0 25/3.0 25/4.0 	89.581.0002 89.582.0002 89.583.0012 89.584.0005	PL 16 PL 25 PL 32 PL 40	Befestigungssatz 25/.. Stützbefestigungen Aluminium exliert	Cylinder mounting Fixation 25/1.0 25/2.0 25/3.0 25/4.0 	89.581.0002 89.582.0002 89.583.0012 89.584.0005	PL 16 PL 25 PL 32 PL 40	Connection Set 25/.. body brackets anodised aluminium
Lastbefestigungen 225/1 225/2 225/3 225/4 	89.581.0003 89.582.0003 89.583.0003 89.584.0003	PL 16 PL 25 PL 32 PL 40	Befestigungssatz 225/.. 1 Lastkupplung m. Buchse 1 Befestigungslasche 1 Bolzen	Load mounting 225/1 225/2 225/3 225/4 	89.581.0003 89.582.0003 89.583.0003 89.584.0003	PL 16 PL 25 PL 32 PL 40	Connection Set 225/.. 1 Load friction with liner 1 articulated carrier 1 bolt
Lastbefestigung 226/3 226/4 227/3 227/4 	89.583.0008 89.584.0008 89.583.0009 89.584.0009	PL 32 PL 40 PL 32 PL 40	Befestigung 226/.. 1 T-Lastkupplung KURZ Befestigung 227/.. 1 T-Lastkupplung LANG	Load mounting 226/3 226/4 227/3 227/4 	89.583.0008 89.583.0008 89.583.0009 89.584.0009	PL 32 PL 40 PL 32 PL 40	Connection Set 226/.. 1 T-mounting SHORT Connection Set 227/.. 1 T-mounting LONG

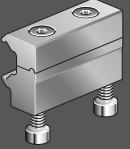
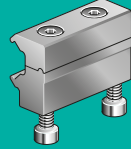
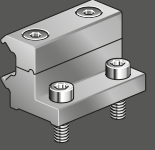
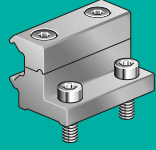
Typen	Ident.-Nr.	Serie	Ausführungen	Types	Ident.-No.	Series	Description
G- Mobile Mittelstütze Ø 16 Ø 25 Ø 32 	89.581.9003 89.582.9003 89.583.9003	PL PLF PLK PLG PLR	Farbe: natur Material: AL	G- Mobile Mittelstütze Ø 16 Ø 25 Ø 32 	89.581.9003 89.582.9003 89.583.9003	PL PLF PLK PLG PLR	Colour: natur Material: AL
W- Mobile Mittelstütz Ø 16 Ø 25 Ø 32 	89.581.9002 89.582.9002 89.583.9002	PL PLF PLK PLG PLR	Farbe: natur Material: AL	W- Mobile Mittelstütz Ø 16 Ø 25 Ø 32 	89.581.9002 89.582.9002 89.583.9002	PL PLF PLK PLG PLR	Colour: natur Material: AL

ERSATZTEILE PL-SERIE

SPAREPART KITS PL-SERIE

- Stellenangaben bei Hubfestlegung (0100-5700 mm)
- Ident-figures for stroke definition (0100-5700 mm)

Typen	Ident.-Nr.	Zyl. -Ø	Ausführungen	Types	Ident.-No.	Zyl. -Ø	Description
Nr. I Universal- STANDARD	11.657.0000 12.557.0000 13.257.0000 14.057.0000	PL16 PL25 PL32 PL40	2xKolben (alternativ Nr. 0, 1, 2, 3 bei Bestellung angeben) Nr. V Nr. VII Nr. VIII	Nr. I Universal- STANDARD	11.657.0000 12.557.0000 13.257.0000 14.057.0000	PL16 PL25 PL32 PL40	2xpiston (alternative No. 0, 1, 2, 3 please specify in order) Nr. V Nr. VII Nr. VIII
Nr. II Universal-VITON	11.657.0001 12.557.0001 13.357.0001 14.057.0001	PL16 PL25 PL32 PL40	2XKolben (alternativ Nr. 0, 1, 2, 3 bei Bestellung angeben) Nr. VI Nr. VII Nr. VIII	Nr. II Universal-VITON	11.657.0001 12.557.0001 13.357.0001 14.057.0001	PL16 PL25 PL32 PL40	2xpiston (alternative No. 0, 1, 2, 3 please specify in order) Nr. V Nr. VII Nr. VIII
Nr. III Dichtband innen	11.658.●●●● 12.558.●●●● 13.258.●●●● 14.058.●●●●	PL16 PL25 PL32 PL40	Dichtband inklusive Justiervernetzung auf Hublänge passend geschnitten	Nr. III Inner sealing band	11.658.●●●● 12.558.●●●● 13.258.●●●● 14.058.●●●●	PL16 PL25 PL32 PL40	sealing band including adjustment rivet according to stroke length
Nr. IV Dichtband außen	11.659.●●●● 12.559.●●●● 13.259.●●●● 14.059.●●●●	PL16 PL25 PL32 PL40	Dichtband außen auf Hublänge passend geschnitten	Nr. IV Outer sealing band	11.659.●●●● 12.559.●●●● 13.259.●●●● 14.059.●●●●	PL16 PL25 PL32 PL40	Outer sealing band according to stroke length
Nr. V Dichtungen-NBR	11.655.0000 12.555.0000 13.255.0000 14.055.0000	PL16 PL25 PL32 PL40	2xKolbendichtung 2xKolbendämpfdichtung 2xO-Ring-Dämpfschraube 2xO-Ring-Zylinderkopf 1xO-Ring-Lastkupplung	Nr. V Seals NBR	11.655.0000 12.555.0000 13.255.0000 14.055.0000	PL16 PL25 PL32 PL40	2Xpiston seal 2Xpiston cushion seal 2Xo-ring cushion seal 2Xo-ring cylinder end cap 1Xo-ring connection
Nr. VI Dichtungen-VITON	11.655.0001 12.555.0001 13.255.0001 14.055.0001	PL16 PL25 PL32 PL40	2xKolbendichtung 2xKolbendämpfdichtung 2xO-Ring-Dämpfschraube 2xO-Ring-Zylinderkopf 1xO-Ring-Lastkupplung	Nr. VI Seals VITON	11.655.0001 12.555.0001 13.255.0001 14.055.0001	PL16 PL25 PL32 PL40	2Xpiston seal 2Xpiston cushion seal 2Xo-ring cushion seal 2Xo-ring cylinder end cap 1Xo-ring connection
Nr. VII Gleitteile	11.656.0000 12.556.0000 13.256.0000 14.056.0000	PL16 PL25 PL32 PL40	2xGleitstücke Nr. 1, 2, 3 oder 4 2xAbstreifer	Nr. VII Slidings	11.656.0000 12.556.0000 13.256.0000 14.056.0000	PL16 PL25 PL32 PL40	2xbearing strip No. 1, 2, 3 oder 4 2xscraper
Nr. VIII Fettpackung	12.589.0000	PL16-40	Normalfett SL32/30 V > =0,1m/s 30g-Dose	Nr. VIII Grease package	12.589.0000	PL16-40	standard grease SL32/30 v > =0,1m/s 30gr. tin
Nr. IX Fettpackung	12.589.0001	PL16-40	Spezialfett LL33/30 v < 0,1m/s 30g-Dose	Nr. IX Grease package	12.589.0001	PL16-40	special grease LL33/30 v < 0,1m/s 30gr. tin
Nr.X Kombisatz	11.689.0002 12.589.0002 13.289.0002 14.089.0002	PL16 PL25 PL32 PL40	Nr.V, Nr. VII, Nr. VIII	Nr. X Combisat Standard	11.689.0002 12.589.0002 13.289.0002 14.089.0002	PL16 PL25 PL32 PL40	Nr.V, Nr. VII, Nr. VIII