

Bellows suction cup NBR (round)

SAB 30 NBR-60 G3/8-IG

Part no.:10.01.06.01198

<https://www.schmalz.com/10.01.06.01198>

Homepage > Vacuum Technology for Automation > Vacuum Components > Vacuum Suction Cups > Suction Cups for Handling Sheet Metal >

Bellows Suction Cups SAB (1.5 Folds) > SAB 30 NBR-60 G3/8-IG

Bellows suction cup (round) for very dynamic handling of smooth and oily workpieces



Size: 30

Suction cup material:

Nitrile rubber NBR

Material hardness: 60 °Sh

Vacuum connection: G3/8"-F

Nipple material: Brass, nickel-plated

Number of folds: 1.5

Design Data

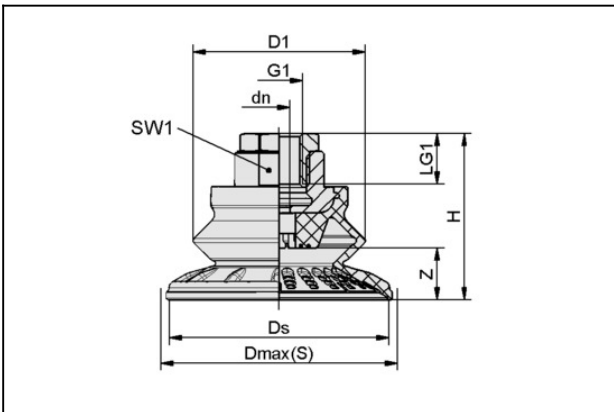

Attribute	Value
dn	4 mm
D1	32 mm
Dmax(S)	34 mm
Ds	30.6 mm
G1	G3/8"-F
H	44 mm
LG1	9.5 mm
SW1	22 mm
Z (Stroke)	9 mm

Bellows suction cup NBR (round)

SAB 30 NBR-60 G3/8-IG

Part no.:10.01.06.01198

<https://www.schmalz.com/10.01.06.01198>



Technical Data

Attribute	Value
Suction force (-600mbar)	22 N
Pull-off force	33 N
Lateral force	30 N
Lateral force (oily surface)	13 N
Volume	5.73 cm ³
Curve radius (min) (convex)	40 mm
Hose diameter (empf.) d	4 mm
Size	30
Suction cup material	Nitrile rubber NBR
Material hardness [Shore A]	60 Shore A
Weight	45.3 g
Product family	SAB
Number of folds	1.5

Note: Suction force: The specified suction forces are theoretical values at a vacuum of -0.6 bar and with a smooth, dry workpiece surface - they do not include a safety factor Lateral force: The specified lateral forces are values measured at a vacuum of -0.6 bar with a dry or oily, smooth, flat workpiece surface. Depending on the workpiece surface and its quality, the actual values may deviate from these values Hose diameter: The recommended hose diameter refers to a hose length of approx. 2 m