

Bellows suction cup HT1 (round)

SAB 40 HT1-60 G3/8-IG

Part no.:10.01.06.03053

<https://www.schmalz.com/10.01.06.03053>

Homepage > Vacuum Technology for Automation > Vacuum Components > Vacuum Suction Cups > Suction Cups for Handling Sheet Metal >

Bellows Suction Cups SAB (1.5 Folds) > SAB 40 HT1-60 G3/8-IG

Bellows suction cup (round) for markless handling of workpieces



Size: 40

Suction cup material:

High temp material HT1

Material hardness: 60 °Sh

Vacuum connection: G3/8"-F

Number of folds: 1.5

Nipple material: Brass, nickel-plated

Design Data

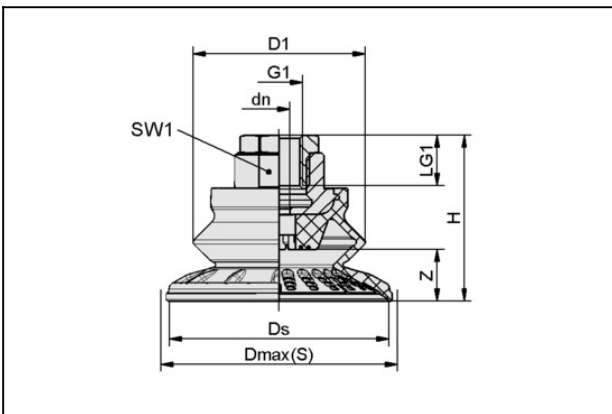

Attribute	Value
dn	4 mm
D1	32 mm
Dmax(S)	45 mm
Ds	40.1 mm
G1	G3/8"-F
H	44.8 mm
LG1	9.5 mm
SW1	22 mm
Z (Stroke)	10 mm

Technical Data

Contact to Schmalz

J. Schmalz GmbH | Johannes-Schmalz-Straße, 72293 Glatten, Deutschland | +49 7443 2403-102 | customercenter@schmalz.de

Bellows suction cup HT1 (round)

SAB 40 HT1-60 G3/8-IG

Part no.:10.01.06.03053

<https://www.schmalz.com/10.01.06.03053>



Attribute	Value
Suction force (-600mbar)	38 N
Pull-off force	59 N
Lateral force	36 N
Lateral force (oily surface)	33 N
Volume	7 cm ³
Curve radius (min) (convex)	40 mm
Hose diameter (empf.) d	4 mm
Size	40
Number of folds	1.5
Suction cup material	High temp material HT1
Material hardness [Shore A]	60 Shore A
Weight	45.3 g
Product family	SAB

Note: Suction force: The specified suction forces are theoretical values at a vacuum of -0.6 bar and with a smooth, dry workpiece surface - they do not include a safety factor Lateral force: The specified lateral forces are values measured at a vacuum of -0.6 bar with a dry or oily, smooth, flat workpiece surface. Depending on the workpiece surface and its quality, the actual values may deviate from these values Hose diameter: The recommended hose diameter refers to a hose length of approx. 2 m