

Gasdruckfedern MICROserie

Gas springs MICROseries

Ressorts à gaz MICROsérie

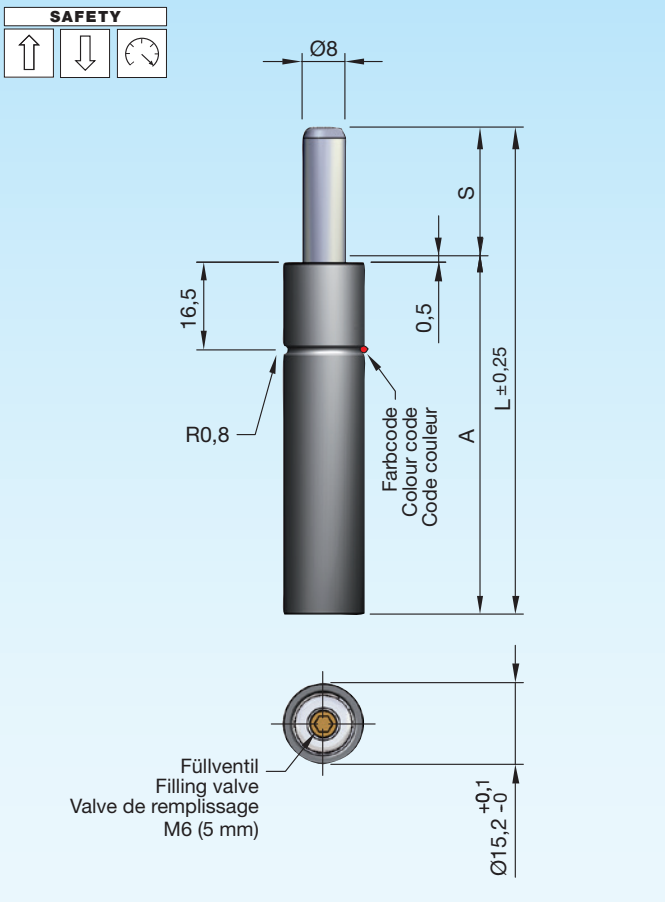

Druckmedium	Pressure medium	Médium de pression	Stickstoff (N₂)
Max. Fülldruck	Max. filling pressure	Pression de rempl. max.	175 bar
Min. Fülldruck	Min. filling pressure	Pression de rempl. min.	50 bar
Max. Betriebs- temperatur	Max. working temperature	Température de service max.	80 °C
Temperaturabhängige Druckerhöhung	Pressure increase due to temperature	Accroissement de pression sous l'influence de la temp.	0,33 %/1 °C
Instandhaltungsset	Maintenance kit	Jeu de maintenance	SN2990-M15
Max. Kolben- geschwindigkeit	Max. piston speed	Vitesse max. du piston	0,8 m/s

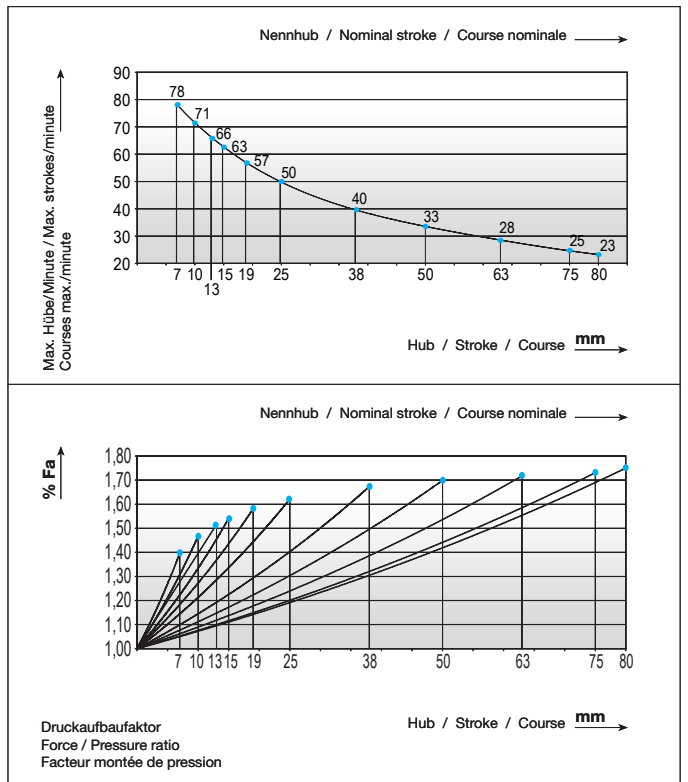

Einbauvarianten / Installation variants / Variantes de montage

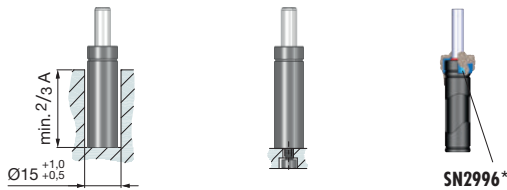

SN2808-90-		S	Type	A	L	V [l]	Fa [cm ²]	kg
	SN2808-90-S-Type	7	1	49	56	0,001	0,50	0,07
S = Hub / Stroke / Course		10	2	52	62	0,002	0,50	0,07
bar = Fülldruck / Filling pressure / Pression de remplissage		13	3	55	68	0,002	0,50	0,08
Type	Farbcode Colour code Code couleur	daN	daN	bar				
1	Grün / Green / Vert	30 (+5)	48	60				
2	Blau / Blue / Bleu	50 (+5)	80	100				
3	Rot / Red / Rouge	70 (+10)	112	140				
4	Gelb / Yellow / Jaune	90 (+10)	140	175				
Andere Kräfte / Other forces / Autres forces		25-90	≈40-140	50-175				

* i SN2996* = Seite / Page 2.3.254