

Bundbohrbuchsen

Collared drill bushes

Canon de perçage à collerette

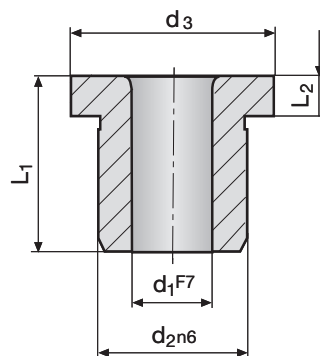

W8305-

Mat.: Werkzeugstahl/
Tool steel/Acier à outils
780±40 HV 10/DIN 172 A

 W8305-d1-L



Stufung:
Graduation:
Progression:

0,4 - 20,0 = 0,1 mm
20,5 - 30,0 = 0,5 mm

Nur für Schneidstempel
nach DIN ISO 8020 geeignet

Only suited for cutting punches
according to DIN ISO 8020

Seulement appropriés pour poinçons
de découpe selon DIN ISO 8020

d1	L1	L2	d2	d3	d1	L1	L2	d2	d3
0,4 - 0,8	6	2	3	6	12,1 - 15,0	16	4	22	26
0,9 - 1,0	6	2	3	6	12,1 - 15,0	28	4	22	26
0,9 - 1,0	9	2	3	6	12,1 - 15,0	36	4	22	26
1,1 - 1,8	6	2	4	7	15,1 - 18,0	16	4	26	30
1,1 - 1,8	9	2	4	7	15,1 - 18,0	28	4	26	30
1,9 - 2,6	6	2	5	8	15,1 - 18,0	36	4	26	30
1,9 - 2,6	9	2	5	8	18,1 - 22,0	20	5	30	34
2,7 - 3,3	8	2,5	6	9	18,1 - 22,0	36	5	30	34
2,7 - 3,3	12	2,5	6	9	18,1 - 22,0	45	5	30	34
2,7 - 3,3	16	2,5	6	9	22,5 - 26,0	20	5	35	39
3,4 - 4,0	8	2,5	7	10	22,5 - 26,0	36	5	35	39
3,4 - 4,0	12	2,5	7	10	22,5 - 26,0	45	5	35	39
3,4 - 4,0	16	2,5	7	10	26,5 - 30,0	25	5	42	46
4,1 - 5,0	8	2,5	8	11	26,5 - 30,0	45	5	42	46
4,1 - 5,0	12	2,5	8	11	26,5 - 30,0	56	5	42	46
4,1 - 5,0	16	2,5	8	11	30,5 - 35,0	25	5	48	52
5,1 - 6,0	10	3	10	13	30,5 - 35,0	45	5	48	52
5,1 - 6,0	16	3	10	13	30,5 - 35,0	56	5	48	52
5,1 - 6,0	20	3	10	13	35,5 - 42,0	30	5	55	59
6,1 - 8,0	10	3	12	15	35,5 - 42,0	56	5	55	59
6,1 - 8,0	16	3	12	15	35,5 - 42,0	67	5	55	59
6,1 - 8,0	20	3	12	15	42,5 - 48,0	30	6	62	66
8,1 - 10,0	12	3	15	18	42,5 - 48,0	56	6	62	66
8,1 - 10,0	20	3	15	18	42,5 - 48,0	67	6	62	66
8,1 - 10,0	25	3	15	18					
10,1 - 12,0	12	4	18	22					
10,1 - 12,0	20	4	18	22					
10,1 - 12,0	25	4	18	22					