

2/2 way solenoid valve normally closed

type 31A, stainless steel body (AISI 303),
direct operated, DN 1,2 – 2,0 mm, M5

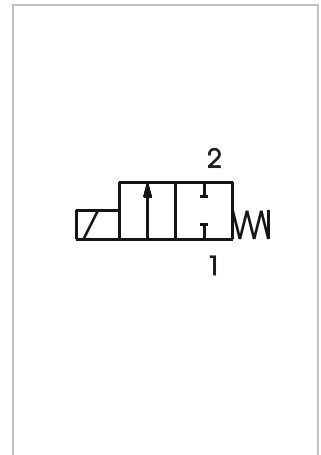
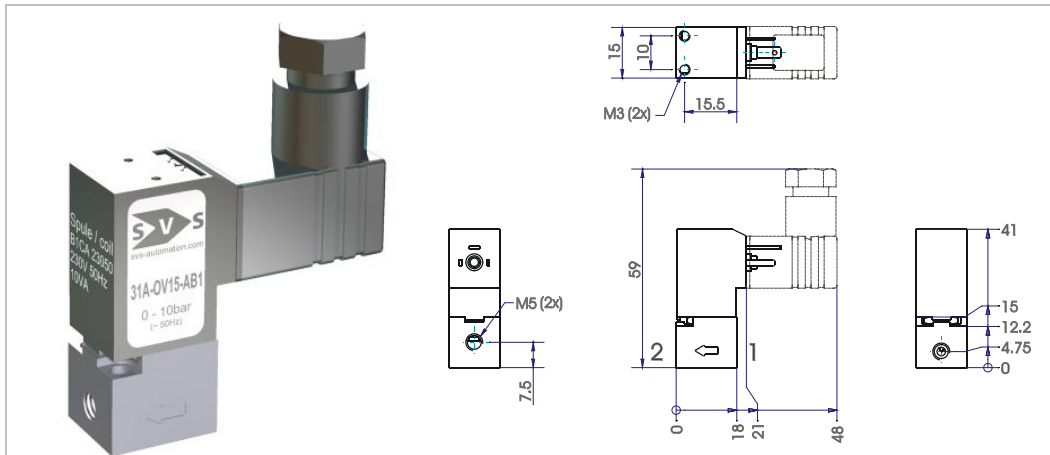

SPECIFICATION	
general	
type of construction	2/2-poppet valve, normally closed NC, coil may be positioned at 0° and 180°
operator	solenoid
ports	M5
ambient temperature	-5 °C to +50 °C
fluid temperature	-10 °C to +80 °C (NBR) or +120 °C (FPM) or +130°C (EPDM)
viscosity	max. 21mm ² /s (cst) or 3° E
material	body and guide tube: AISI303 inner parts: stainless steel sealing: see type selection
mounting	2 fixing holes for screws M2.5 or threads M3
installation	in any position, preferable vertical fixed solenoid coil
unit of supply	without connector according to DIN EN 175301-803 (DIN 43650), type C
electrical data	
voltage	DC voltage or AC voltage
standard voltage	24V DC, 24V AC, 230V AC
special voltage	12V DC, 110V AC
acceptable voltage tolerance	+/- 10%
power consumption	for AC 2,8 VA inrush power, 3,3 VA rated power, for DC 2,65 W (cold) 2,3 W (at operating temperature)
coil type	temperature class F (155°C), winding class H (180°C)
duty cycle	100% ED (DB), continuous operation
protection class	IP65 according DIN EN 60529 (DIN 40050) with correctly mounted connector
pneumatic – hydraulic	
flow medium	all liquids and gases, which don't attack the used material
max. body housing pressure	PN 40 (bar)
response time	8 – 15 ms
operating frequency	max. 1800 / min
weight	approx. 58 g

E & OE: We reserve the right to change design, dimensions or materials without notice.

type 31A, normally closed, alternating current (~, AC) **				
type * (order-nr.)	NW DN (mm)	max. differential pressure (bar)	kv-value (m³/h)	Valves are suitable for vacuum.
31A – 0.12 – AB1CA	1,2	0 – 16	0,043	
31A – 0.15 – AB1CA	1,5	0 – 10	0,055	
31A – 0.20 – AB1CA	2,0	0 – 4	0,080	

type 31A, normally closed, direct current (=, DC) ***				
type * (order-nr.)	NW DN (mm)	max. differential pressure** (bar)	kv-value (m³/h)	Valves are suitable for vacuum.
31A – 0.12 – XB1CA	1,2	0 – 10	0,043	
31A – 0.15 – XB1CA	1,5	0 – 5	0,055	
31A – 0.20 – XB1CA	2,0	0 – 2	0,080	

* Type designation (order-nr.) must be completed with sealing material and supply voltage. (see order code)

** Please note, a short circuit ring made of copper is built in the AC (alternate current) type.

*** At DC voltage all pressure specifications apply to a fluid temperature up to 40 °C. At higher fluid temperatures, the maximum differential pressure will be reduced by 0,3% / °C.

sealing material	Code	fluid temperature	applicable for	standard voltage	Code
NBR (Perbunan)	B	max. 80°C	neutral gases and liquids	24V = (DC)	02400
EPDM	E	max. 130°C	hot water, steam	24V ~ (AC, 50Hz)	02450
FPM	V	max. 120° C	hot water, oil, petrol, oxygen	230V ~ (AC, 50Hz)	23050

order code	
	31 A - 0 V 15 - A B1CA 02450
type	type 31, body and medium contacted parts – stainless steel
function	A = normally closed
ports	0 = M5
seal material	B = NBR (Perbunan), E = EPDM, V = FPM
nominal size seat	12 = 1,2mm, 15 = 1,5mm, 20 = 2,0mm
short circuit ring	A = copper short circuit ring, X = without short circuit ring
coil type	connection according to DIN EN 175301-803 (DIN 43650), type C, others see coil data sheet
supply voltage	always 5-digit, see code of standard voltage