

## SERIE 72AL

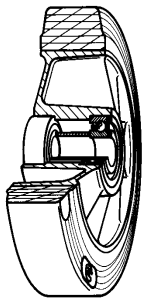

**SIGMA ELASTIC RUBBER WHEELS,  
ALUMINIUM CENTRE,  
FIXED ELECTROWELDED SPRUNG-LOADED BRACKET  
TYPE EES MHD**

### Wheel description



**Tread:** Sigma Elastic rubber tread; hardness 70 +/-3 Shore A.

**Centre:** aluminium.

**Hub:** The housing is obtained by moulding and contains ball bearings series Z..

### Bracket description

**Electrowelded sprung-loaded bracket EES MHD-max loading capacity 1000 daN (damping up to 400 daN)**

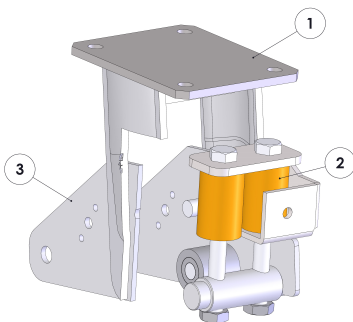

- 1) Electrolytically galvanised top plate with deep-drawn legs electrowelded to the flange
- 2) Polyurethane springs
- 3) Internal moving fork: deep-drawn legs electrowelded to the tube